

Yalıtımsız Kapı Serisi Açılım Varyasyonları

Noninsulated Door Serie Opening Variations

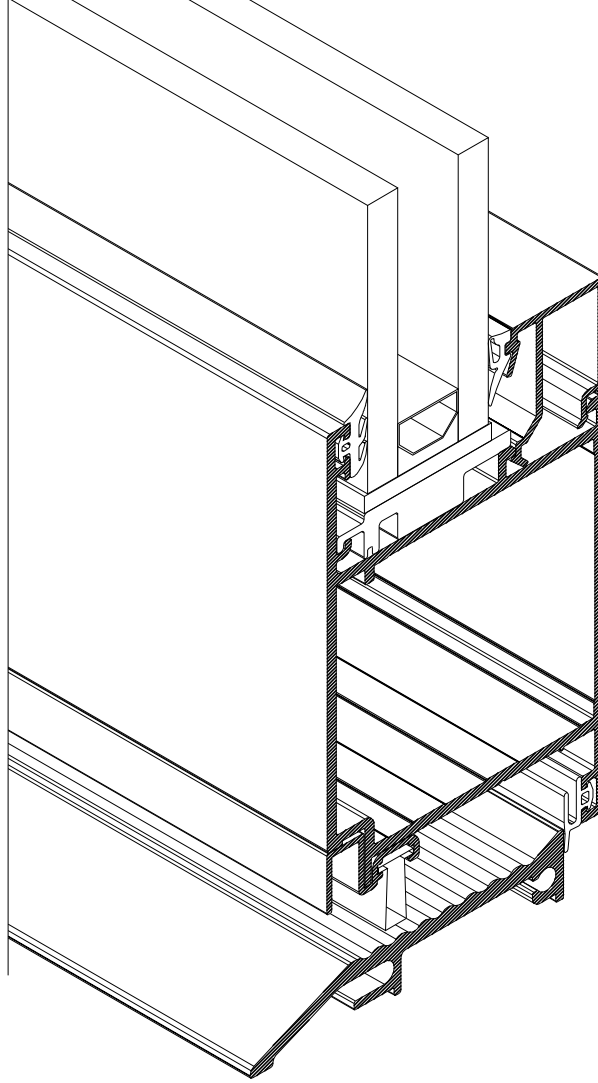
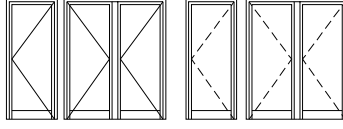

D2

D55 - Yalıtımsız Kapı Serisi

D55 - Noninsulated Door Serie

Alaşım Özellikleri

Alloy Properties

EN AW 6060 (AlMgSi0,5 F22) EN AW 6063(AlMg0,7Si F22)











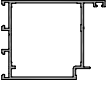
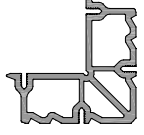
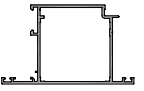
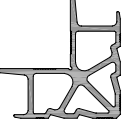
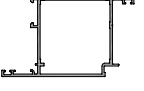
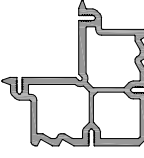

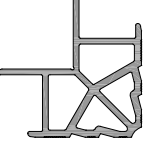

Üretim ve Mekanik Standartları

Production and Mechanical Standards

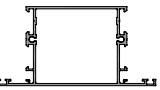
EN 12020-2 - EN 755-9 - EN 755-2

D2

ÜRÜN TEKNİK ÖZELLİKLERİ
PRODUCT'S TECHNICAL FEATURES























PROFİL KESİTİ PROFILE VIEW	PROFİL NO PROFILE NO	PROFİL AÇIKLAMASI PROFILE DESCRIPTION	gr/m	PROFİL KESİTİ PROFILE VIEW	PROFİL NO PROFILE NO	PROFİL AÇIKLAMASI PROFILE DESCRIPTION	gr/m
	D2-101 (52 - 72)	KASA PROFİLİ FRAME	1262		W-603 (90 - 90) 34.6mm	KÖŞE BİRLEŞTİRME CORNER CLEATS	4871
	D2-201 (52 - 92)	DIŞA AÇILIR KANAT PROFİLİ OUTDOOR CASEMENT PROFILE	1368		W-613 (85 - 85) 34.6mm	KÖŞE BİRLEŞTİRME CORNER CLEATS	3945
	D2-202 (72 - 72)	İÇE AÇILIR KANAT PROFİLİ INDOOR CASEMENT PROFILE	1365		W-604 (101 - 47.6) 47.6mm	KÖŞE BİRLEŞTİRME CORNER CLEATS	5539
	D2-501 (14.4 - 42.6)	KASA AÇILIM ADAPTÖRÜ FRAME OPENING ADAPTER	232		W-614 (100 - 100) 47.6mm	KÖŞE BİRLEŞTİRME CORNER CLEATS	5318
	D2-502 (42 - 515)	DIŞA AÇILIM KANAT ADAPT. OUTDOOR OPENING CASEMENT ADAPTER	702	 ⚠ İşaretti profil için satış ekibinden bilgi alınır.	D1-505 (20 - 20)	ETEK ADAPTÖRÜ PLINTH ADAPTER	199
	D2-503 (35 - 50.2)	İÇE AÇILIM KANAT ADAPT. INDOOR OPENING CASEMENT ADAPTER	697		W-557 (24.5 - 20.5)	ETEK ADAPTÖRÜ PLINTH ADAPTER	260
	W-555 (17 - 47.5)	EŞİK PROFİLİ THRESHOLD PROFILE	PVC 767 POLYAMİD 758		W-558 (37.6 - 20)	ETEK ADAPTÖRÜ PLINTH ADAPTER	173
	W2-401 (110 - 70)	ETEK-ORTA KAYIT PROFİLİ PLINTH-TRANSOM PROFILE	1511		W-559 (37.6 - 20)	ETEK ADAPTÖRÜ PLINTH ADAPTER	216
	W2-403 (140 - 120)	ETEK PROFİLİ PLINTH PROFILE	1821	 ⚠ İşaretti profil için satış ekibinden bilgi alınır.	W-556 (10.5 - 18.3)	DAMLALIK PROFİLİ WEATHERDROPP PROFILE	126
	W2-402 (101 - 57)	ETEK PROFİLİ PLINTH PROFILE	2081		W1-508 (4.2 - 19)	TİJ PROFİLİ PUSHING ROD PROFILE	138

Profil değerleri teoriktir. Ağırlık olarak testimde yapılan tartım geçerlidir.
Profil imalatları TS EN 12020-2 ve TS EN 755-9 toleransı,
Moment değerleri EN 14024'e göre hesaplanmıştır.

Profile values are theoretical pre-shipment weight will be valid.
The tolerances of Profile manufacturing are calculated according to EN 12020-2
and TS EN 755-9; moment values are calculated according to EN 14024.

D2

ÜRÜN TEKNİK ÖZELLİKLERİ
PRODUCT'S TECHNICAL FEATURES

PROFİL KESİTİ PROFILE VIEW	PROFİL NO PROFILE NO	PROFİL AÇIKLAMASI PROFILE DESCRIPTION	gr/m	PROFİL KESİTİ PROFILE VIEW	PROFİL NO PROFILE NO	PROFİL AÇIKLAMASI PROFILE DESCRIPTION	gr/m
	W-511 (3.5 - 24.5)	CAM ÇİTASI GLASS BEAM	187		W-512-a (7.5 - 24.5)	CAM ÇİTASI GLASS BEAM	194
	W-512 (7.5 - 24.5)	CAM ÇİTASI GLASS BEAM	206		W-513-a (11.5 - 24.4)	CAM ÇİTASI GLASS BEAM	216
	W-513 (11.5 - 24.5)	CAM ÇİTASI GLASS BEAM	227		W-514-a (15.5 - 24.4)	CAM ÇİTASI GLASS BEAM	228
	W-514 (15.5 - 24.5)	CAM ÇİTASI GLASS BEAM	252		W-515-a (19.5 - 24.4)	CAM ÇİTASI GLASS BEAM	242
	W-515 (19.5 - 24.5)	CAM ÇİTASI GLASS BEAM	273		W-516-a (23.5 - 24.4)	CAM ÇİTASI GLASS BEAM	270
	W-516 (23.5 - 24.5)	CAM ÇİTASI GLASS BEAM	286		W-517-a (27.5 - 24.4)	CAM ÇİTASI GLASS BEAM	284
	W-517 (27.5 - 24.5)	CAM ÇİTASI GLASS BEAM	299		W-518-a (31.5 - 24.4)	CAM ÇİTASI GLASS BEAM	297
	W-518 (31.5 - 24.5)	CAM ÇİTASI GLASS BEAM	316		W-519-a (35.5 - 24.4)	CAM ÇİTASI GLASS BEAM	316
	W-519 (35.5 - 24.5)	CAM ÇİTASI GLASS BEAM	336		W-520-a (39.5 - 24.4)	CAM ÇİTASI GLASS BEAM	330
	W-520 (39.5 - 24.5)	CAM ÇİTASI GLASS BEAM	351		W-521-a (43.5 - 24.4)	CAM ÇİTASI GLASS BEAM	344
	W-511-a (3.5 - 24.4)	CAM ÇİTASI GLASS BEAM	193		W-522-a (29.5 - 24.4)	CAM ÇİTASI GLASS BEAM	278













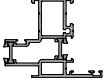

 İşaretili profil için satış temsilcinizden bilgi alınuz.

Profil değerleri teoriktir. Ağırlık olarak testimde yapılan tartım geçerlidir.
Profil imalatları TS EN 12020-2 ve TS EN 755-9 toleransı,
Moment değerleri EN 14024'e göre hesaplanmıştır.

Profile values are theoretical pre-shipment weight will be valid.
The tolerances of Profile manufacturing are calculated according to EN 12020-2
and TS EN 755-9; moment values are calculated according to EN 14024.

D2

ÜRÜN TEKNİK ÖZELLİKLERİ
PRODUCT'S TECHNICAL FEATURES

PROFİL KESİTİ PROFILE VIEW	PROFİL NO PROFILE NO	PROFİL AÇIKLAMASI PROFILE DESCRIPTION	gr/m	PROFİL KESİTİ PROFILE VIEW	PROFİL NO PROFILE NO	PROFİL AÇIKLAMASI PROFILE DESCRIPTION	gr/m
	W-509 (95 - 4)	LAMBİRİ PROFİLİ WAINSCOT PROFILE	319	 ⚠ İşaretti profil için satış ekibinden bilgi alınır.	W4-506 (30.5 - 55)	AÇILIM ADAPTÖRÜ OPENING ADAPTER	698
	W-510 (4.3 - 92.7)	LAMBİRİ PROFİLİ WAINSCOT PROFILE	342		W3-106 (4.9 - 29)	CEPHE-PENCERE ADAPTÖRÜ FACADE-WINDOW ADAPTER	PVC 1563 POLYAMİD 1554
	W-521 (124 - 10)	LAMBİRİ PROFİLİ WAINSCOT PROFILE	805		W-609 (50.6 - 39.3)	ORTA KAYIT BİRLEŞTİRME CORNER CLEATS FOR TRANSOM	867
	W-522 (88 - 10)	LAMBİRİ PROFİLİ WAINSCOT PROFILE	519		W-610 (51.1 - 39.1)	ORTA KAYIT BİRLEŞTİRME CORNER CLEATS FOR TRANSOM	938
	W-544 (88 - 10)	EŞİK PROFİLİ THRESHOLD PROFILE	728	 ⚠ İşaretti profil için satış ekibinden bilgi alınır.	W-609\2 (47.9 - 47.9)	ORTA KAYIT BİRLEŞTİRME CORNER CLEATS FOR TRANSOM	1306
	W-545 (62.3 - 12)	EŞİK PROFİLİ THRESHOLD PROFILE	578		W4-508 (17.3 - 55)	PERVAZ ADAPTÖRÜ FRAME ADAPTER	356
	W4-504 (17.3 - 25)	ETEK ADAPTÖRÜ PLINTH ADAPTER	227				
	W4-505 (12.8 - 25)	ETEK ADAPTÖRÜ PLINTH ADAPTER	184				
	W4-502 (28.3 - 55)	AÇILIM ADAPTÖRÜ OPENING ADAPTER	585				
	W3-511 (16 - 57.4)	CEPHE BAĞLANTI PROFİLİ CONNECTION PROFILE FOR FACADE	496				

⚠ İşaretti profil için satış ekibinden bilgi alınır.

Profil değerleri teoriktir. Ağırlık olarak testimde yapılan tartım geçerlidir.
Profil imalatları TS EN 12020-2 ve TS EN 755-9 toleransı,
Moment değerleri EN 14024'e göre hesaplanmıştır.

Profile values are theoretical pre-shipment weight will be valid.
The tolerances of Profile manufacturing are calculated according to EN 12020-2
and TS EN 755-9; moment values are calculated according to EN 14024.

D2
D 55 YALITIMSIZ KAPI PROFİLLERİ
D55 NONINSULATED SERIES

ÜRÜN TEKNİK ÖZELLİKLERİ
PRODUCT'S TECHNICAL FEATURES

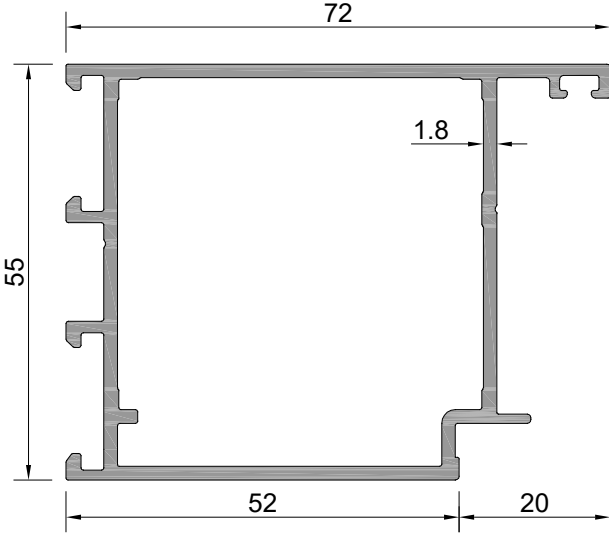

Profil No: D2-101
Ağırlık : 1262 gr/m
Ix : 21,45 cm⁴
ly : 24,32 cm⁴

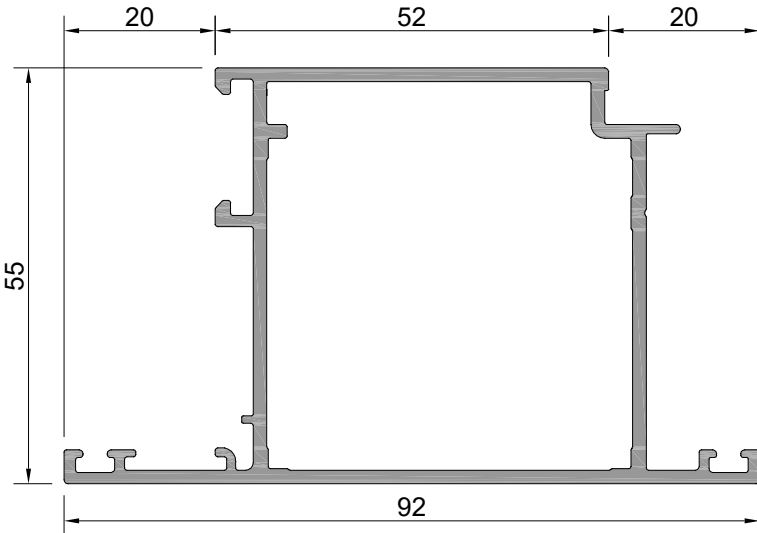
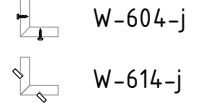

Profil No: D2-201
Ağırlık : 1368 gr/m
Ix : 24,08 cm⁴
ly : 31,34 cm⁴

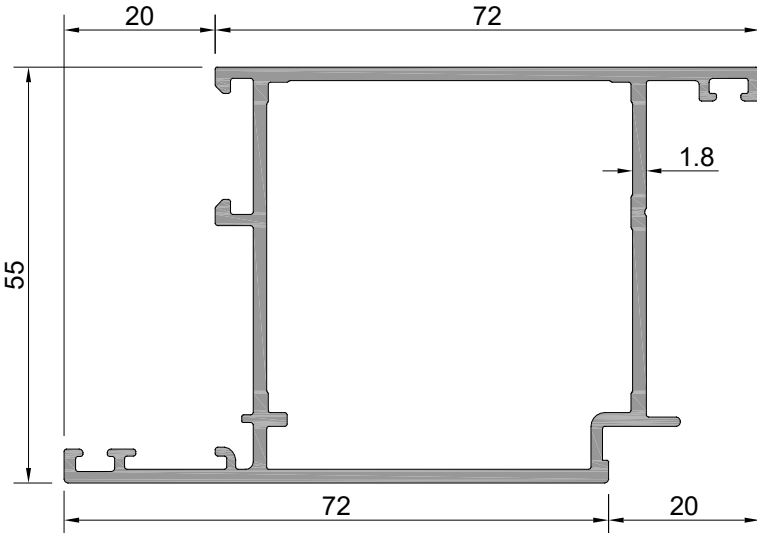
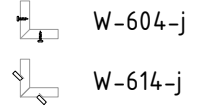

Profil No: D2-202
Ağırlık : 1365 gr/m
Ix : 24,77 cm⁴
ly : 31,26 cm⁴

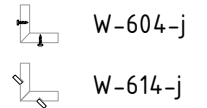

D2
D 55 YALITIMSIZ KAPI PROFİLLERİ
D55 NONINSULATED SERIES

ÜRÜN TEKNİK ÖZELLİKLERİ
PRODUCT'S TECHNICAL FEATURES

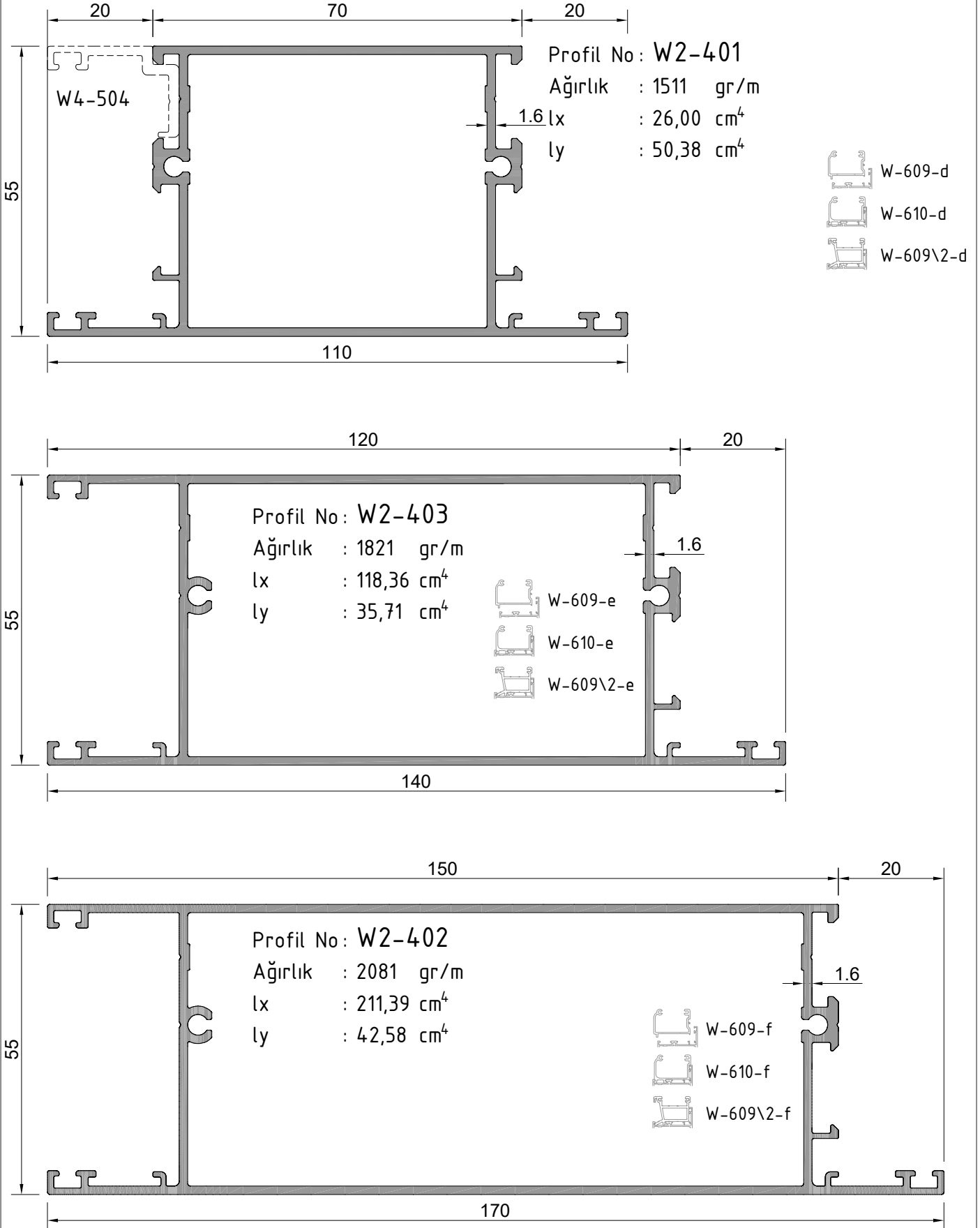

D2
D 55 YALITIMSIZ KAPI PROFİLLERİ
D55 NONINSULATED SERIES

ÜRÜN TEKNİK ÖZELLİKLERİ
PRODUCT'S TECHNICAL FEATURES

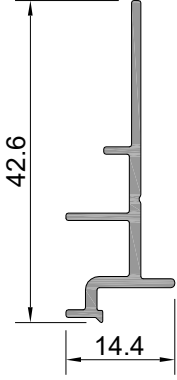

Profil No : D2-501
Ağırlık : 232 gr/m

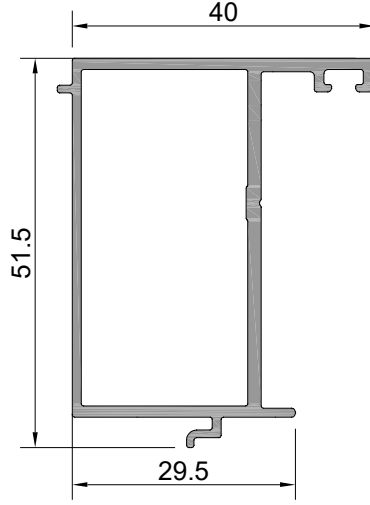

Profil No : D2-502
Ağırlık : 702 gr/m

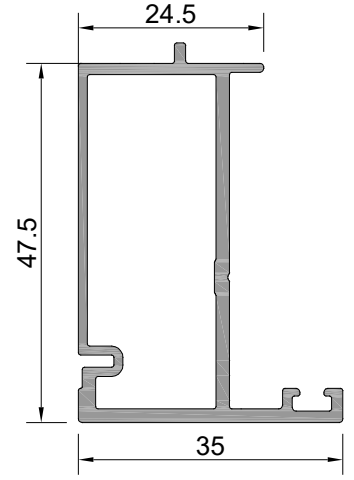

Profil No : D2-503
Ağırlık : 697 gr/m

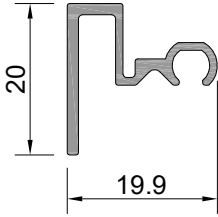

Profil No : D1-505 ⚠
Ağırlık : 199 gr/m
⚠ İşaretili profil için satış ekibinden bilgi alınır.

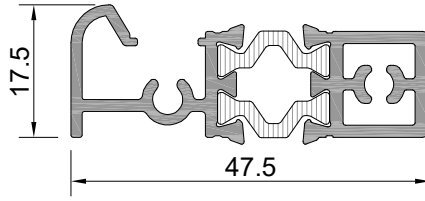

Profil No : W-555

Ağırlık PVC	: 767	gr/m
Ağırlık POLY	: 758	gr/m

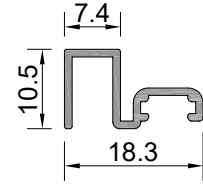

Profil No : W-556 ⚠
Ağırlık : 126 gr/m
⚠ İşaretili profil için satış ekibinden bilgi alınır.

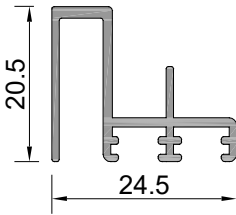

Profil No : W-557
Ağırlık : 260 gr/m

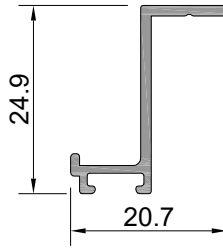

Profil No : W-558
Ağırlık : 173 gr/m

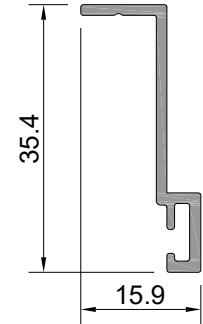

Profil No : W-559
Ağırlık : 216 gr/m

D2
D 55 YALITIMSIZ KAPI PROFİLLERİ
D55 NONINSULATED SERIES

ÜRÜN TEKNİK ÖZELLİKLERİ
PRODUCT'S TECHNICAL FEATURES

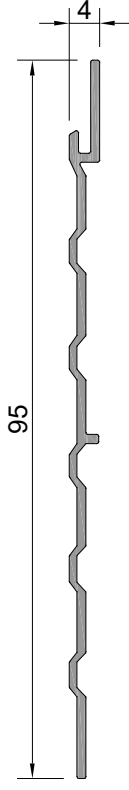

Profil No: W-509
Ağırlık : 319 gr/m

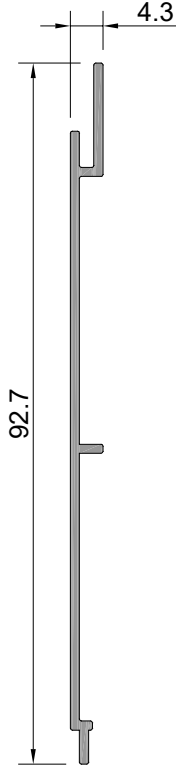

Profil No: W-510
Ağırlık : 342 gr/m

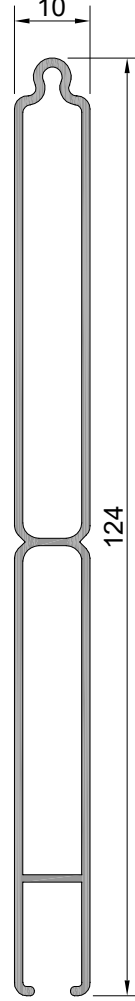

Profil No: W-521
Ağırlık : 805 gr/m

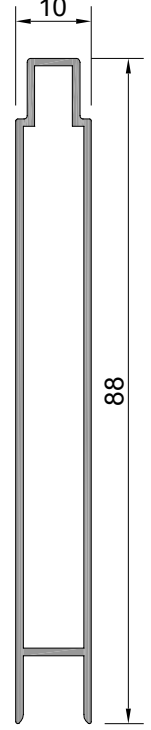

Profil No: W-522
Ağırlık : 519 gr/m

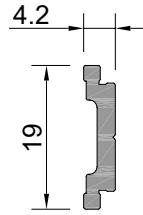

Profil No: W1-508
Ağırlık : 138 gr/m

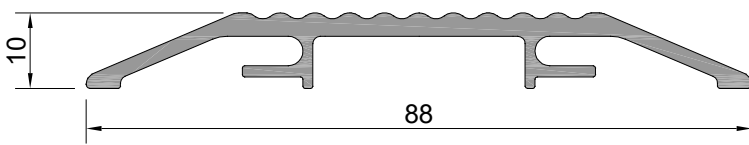

Profil No: W-544
Ağırlık : 728 gr/m

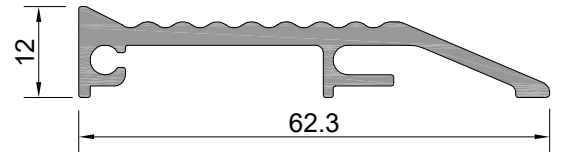

Profil No: W-545
Ağırlık : 578 gr/m

D2
D 55 YALITIMSIZ KAPI PROFİLLERİ
D55 NONINSULATED SERIES

ÜRÜN TEKNİK ÖZELLİKLERİ
PRODUCT'S TECHNICAL FEATURES

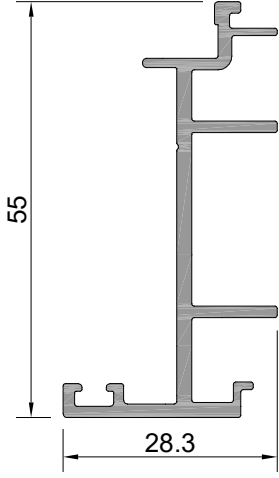

Profil No : W4-502
Ağırlık : 585 gr/m

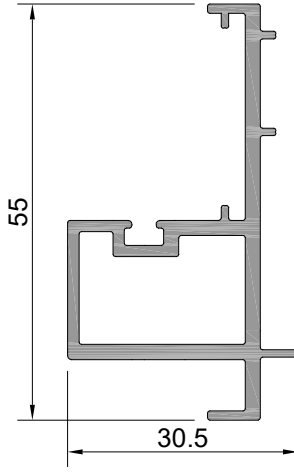

Profil No : W4-506 ⚠
Ağırlık : 698 gr/m
⚠ İşaretili profil için satış ekibinden bilgi alınız.

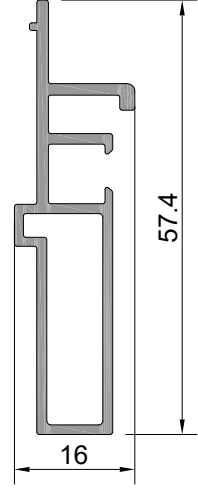

Profil No : W3-511 ⚠
Ağırlık : 496 gr/m
⚠ İşaretili profil için satış ekibinden bilgi alınız.

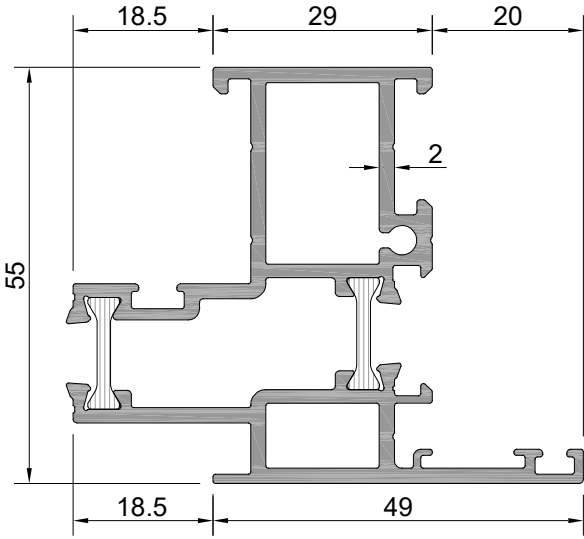

Profil No : W3-106

Ağırlık PVC	: 1563	gr/m
Ağırlık POLY	: 1554	gr/m
I_x	: 13,37	cm ⁴
I_y	: 12,14	cm ⁴

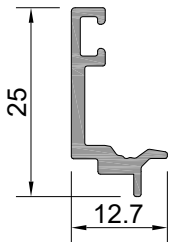
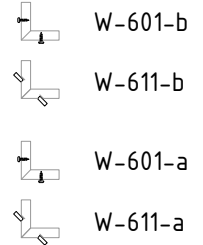

Profil No : W4-505
Ağırlık : 184 gr/m

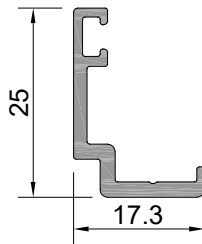

Profil No : W4-504
Ağırlık : 227 gr/m

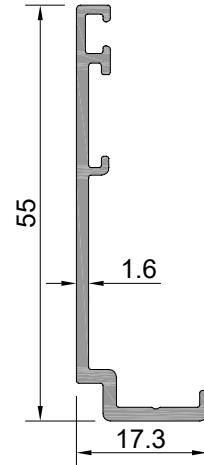

Profil No : W4-508
Ağırlık : 356 gr/m

D2
D 55 YALITIMSIZ KAPI PROFİLLERİ
D55 NONINSULATED SERIES

ÜRÜN TEKNİK ÖZELLİKLERİ
PRODUCT'S TECHNICAL FEATURES

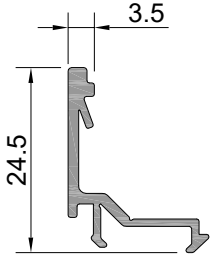

Profil No : W-511
Ağırlık : 187 gr/m

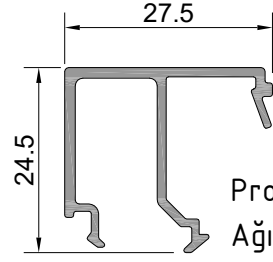

Profil No : W-517
Ağırlık : 299 gr/m

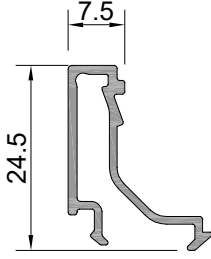

Profil No : W-512
Ağırlık : 206 gr/m

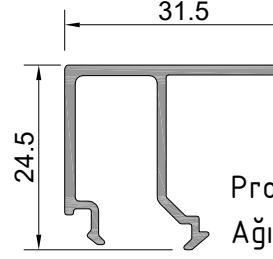

Profil No : W-518
Ağırlık : 316 gr/m

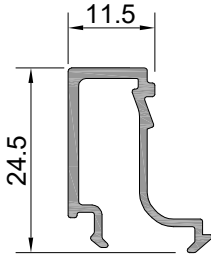

Profil No : W-513
Ağırlık : 227 gr/m

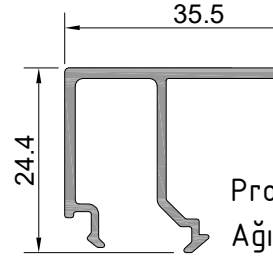

Profil No : W-519
Ağırlık : 336 gr/m

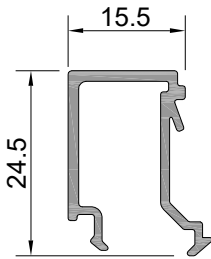

Profil No : W-514
Ağırlık : 252 gr/m

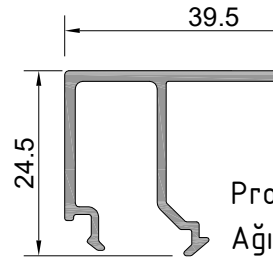

Profil No : W-520
Ağırlık : 351 gr/m

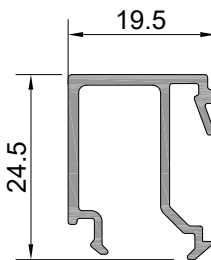

Profil No : W-515
Ağırlık : 273 gr/m

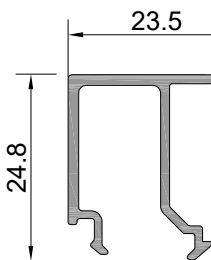

Profil No : W-516
Ağırlık : 286 gr/m

D2
D 55 YALITIMSIZ KAPI PROFİLLERİ
D55 NONINSULATED SERIES

CAM - FİTİL - CAM ÇİTASI
GLAZING-GASKET-GLAZING BELT

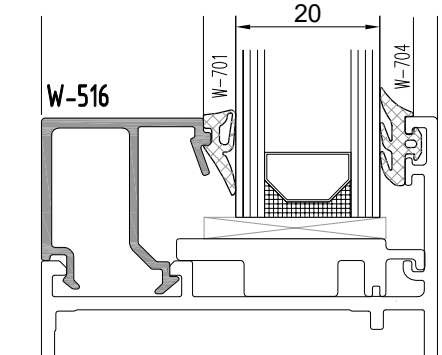
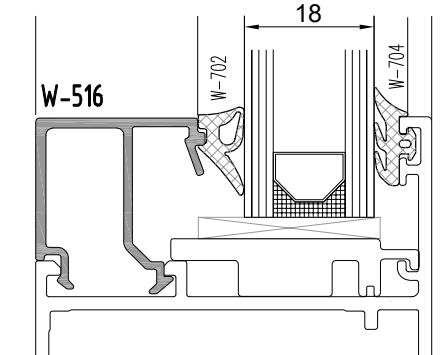
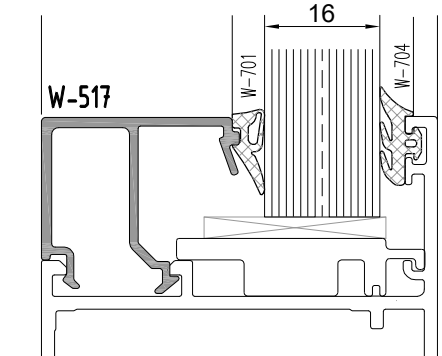
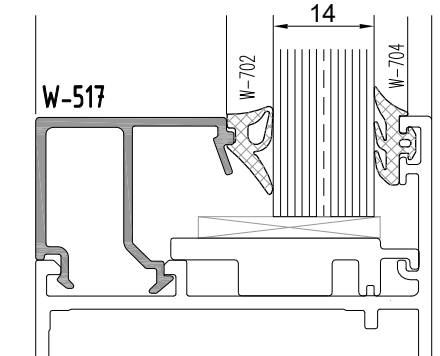
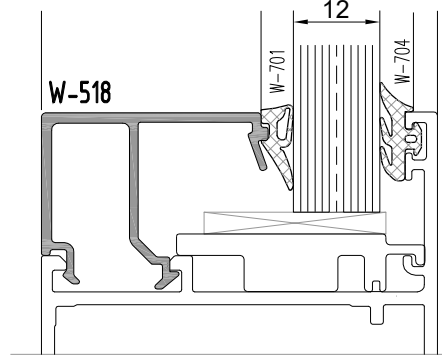
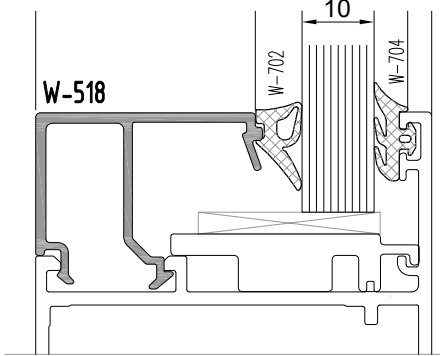
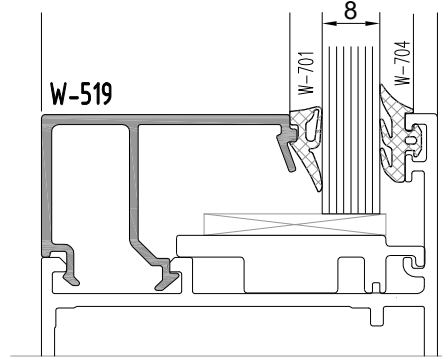
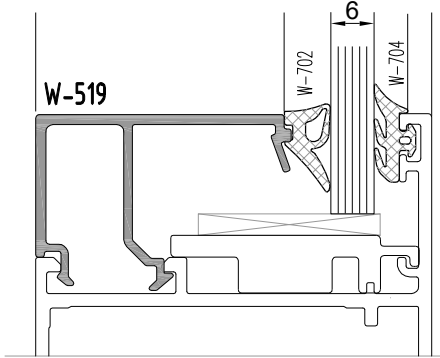
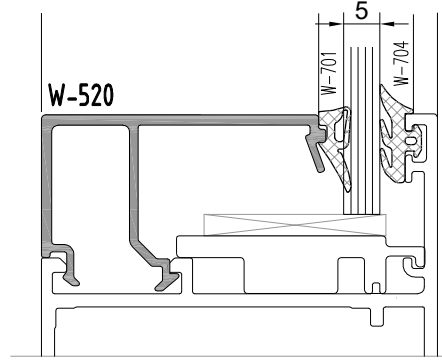
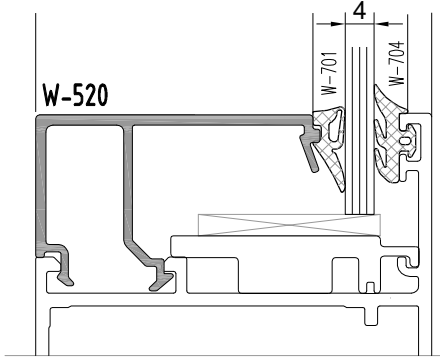

Profil değerleri teoriktir. Ağırlık olarak testimde yapılan tartım geçerlidir.
Profil imalatları TS EN 12020-2 ve TS EN 755-9 toleransı,
Moment değerleri EN 14024'e göre hesaplanmıştır.

Profile values are theoretical pre-shipment weight will be valid.
The tolerances of Profile manufacturing are calculated according to EN 12020-2
and TS EN 755-9; moment values are calculated according to EN 14024.

D2
D 55 YALITIMSIZ KAPI PROFİLLERİ
D55 NONINSULATED SERIES

CAM - FİTİL - CAM ÇİTASI
GLAZING-GASKET-GLAZING BELT

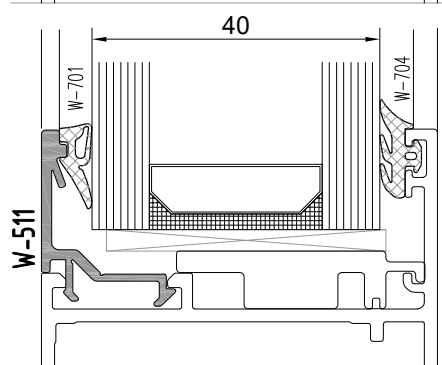
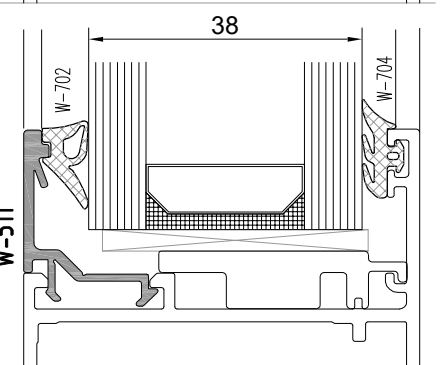
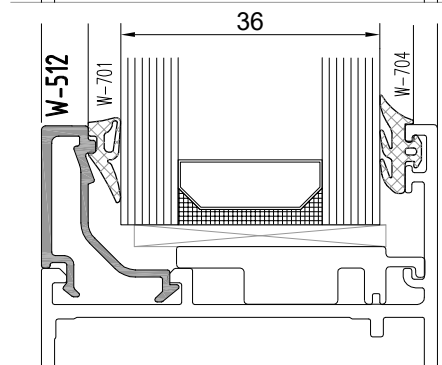
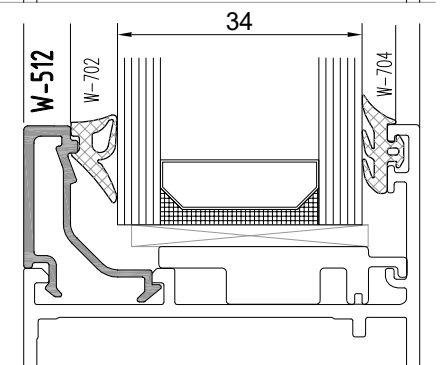
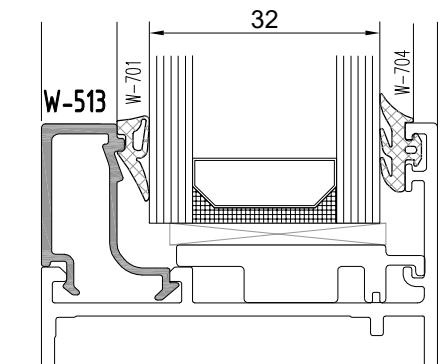
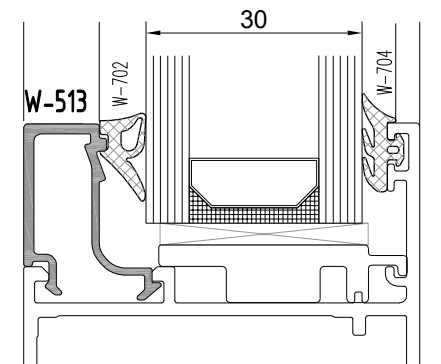
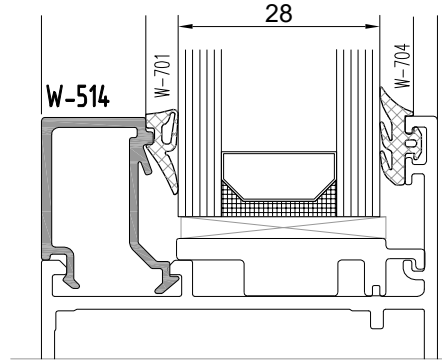
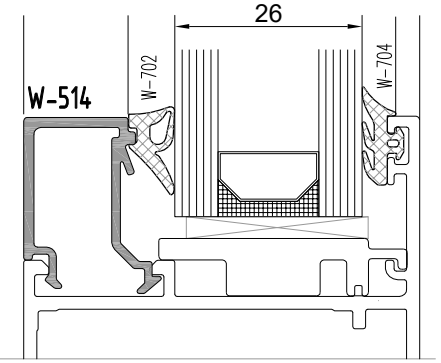
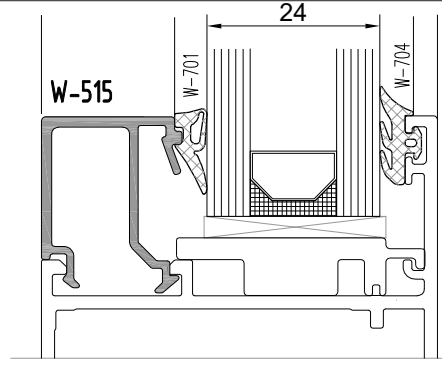
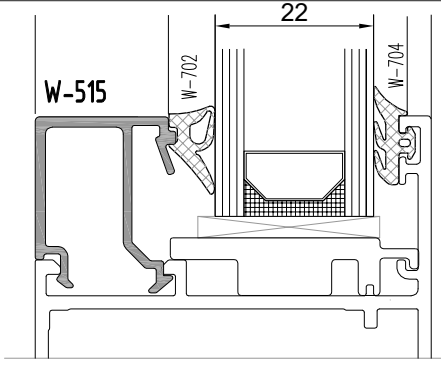

Profil değerleri teoriktir. Ağır olarak testimde yapılan tartım geçerlidir.
Profil imalatları TS EN 12020-2 ve TS EN 755-9 toleransı,
Moment değerleri EN 14024'e göre hesaplanmıştır.

Profile values are theoretical pre-shipment weight will be valid.
The tolerances of Profile manufacturing are calculated according to EN 12020-2
and TS EN 755-9; moment values are calculated according to EN 14024.

D2
D 55 YALITIMSIZ KAPI PROFİLLERİ
D55 NONINSULATED SERIES

ÜRÜN TEKNİK ÖZELLİKLERİ
PRODUCT'S TECHNICAL FEATURES

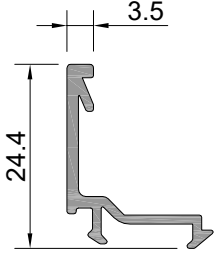

Profil No: W-511-a ⚠
Ağırlık : 193 gr/m

⚠ İşaretti profil için satış temsilcimizden bilgi alınır.

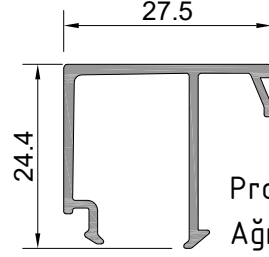

Profil No: W-517-a
Ağırlık : 284 gr/m

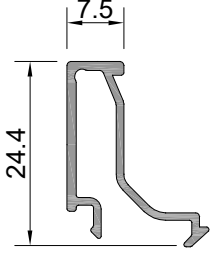

Profil No: W-512-a
Ağırlık : 194 gr/m

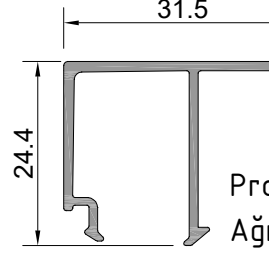

Profil No: W-518-a
Ağırlık : 297 gr/m

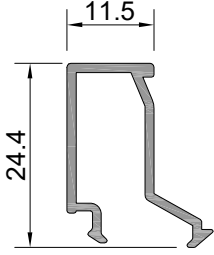

Profil No: W-513-a
Ağırlık : 216 gr/m

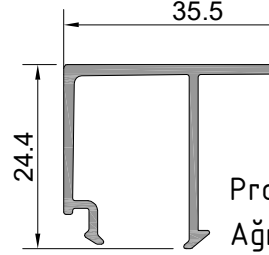

Profil No: W-519-a
Ağırlık : 316 gr/m

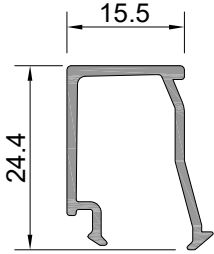

Profil No: W-514-a
Ağırlık : 228 gr/m

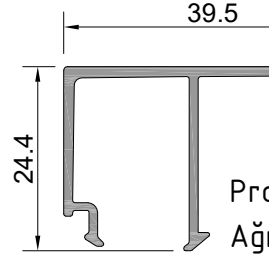

Profil No: W-520-a
Ağırlık : 330 gr/m

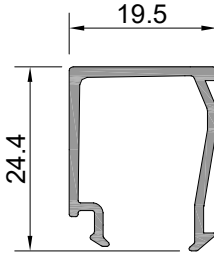

Profil No: W-515-a
Ağırlık : 242 gr/m

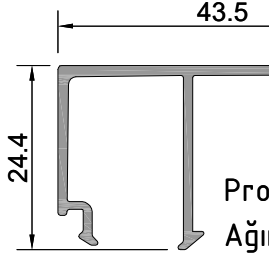

Profil No: W-521-a
Ağırlık : 344 gr/m

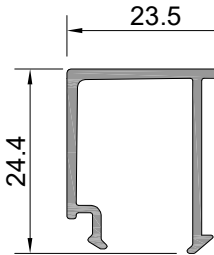

Profil No: W-516-a
Ağırlık : 270 gr/m

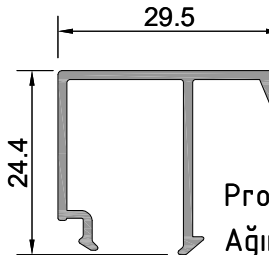

Profil No: W-522-a
Ağırlık : 278 gr/m

D2
D 55 YALITIMSIZ KAPI PROFİLLERİ
D55 NONINSULATED SERIES

CAM - FİTİL - CAM ÇİTASI
GLAZING-GASKET-GLAZING BELT

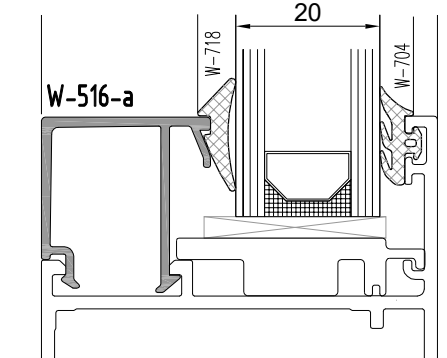
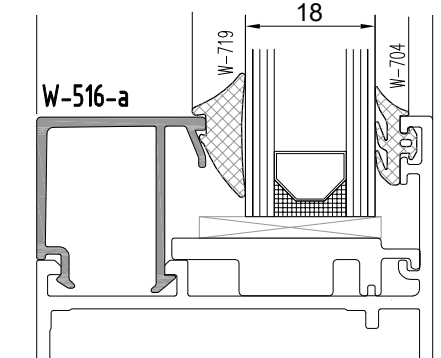
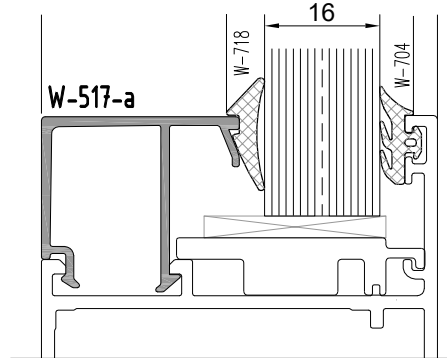
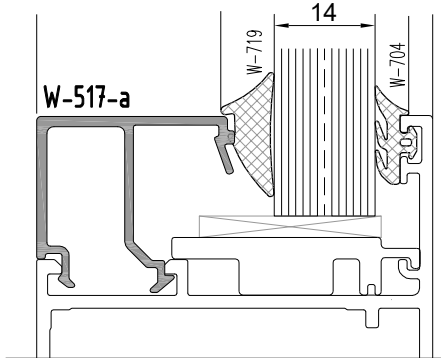
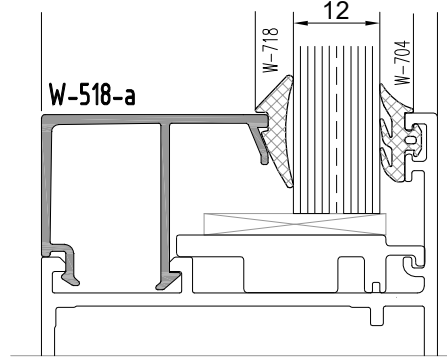
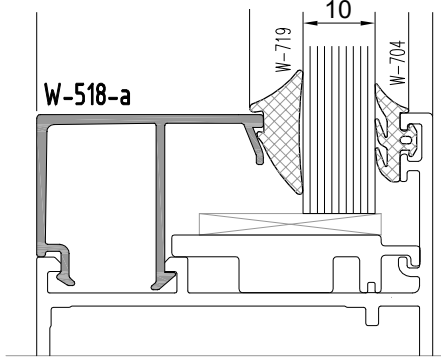
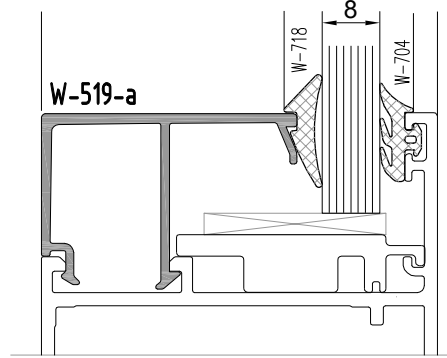
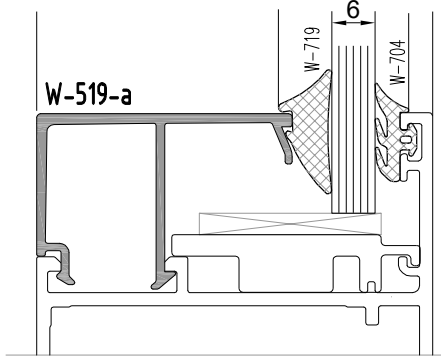
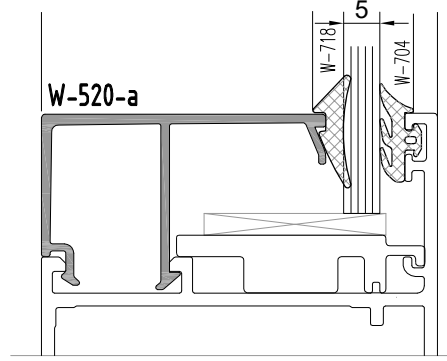
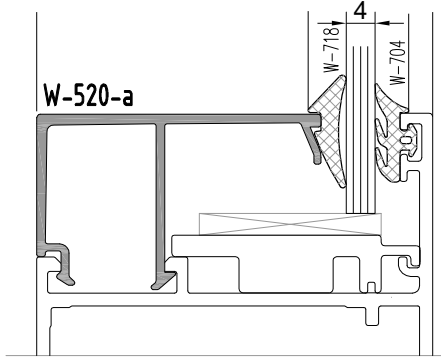

D2
D 55 YALITIMSIZ KAPI PROFİLLERİ
D55 NONINSULATED SERIES

CAM - FİTİL - CAM ÇİTASI
GLAZING-GASKET-GLAZING BELT

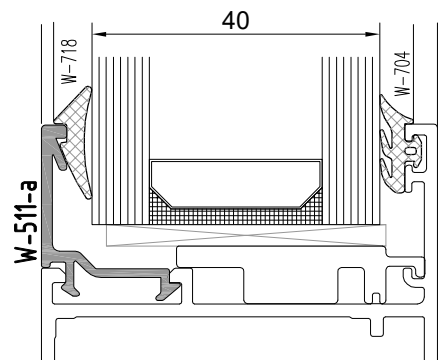
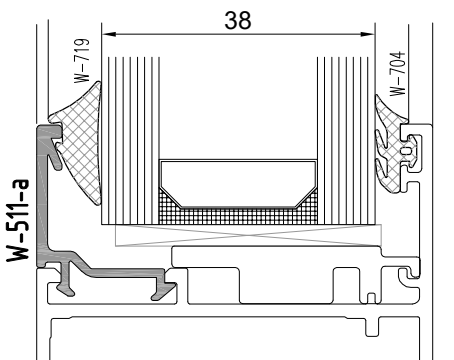
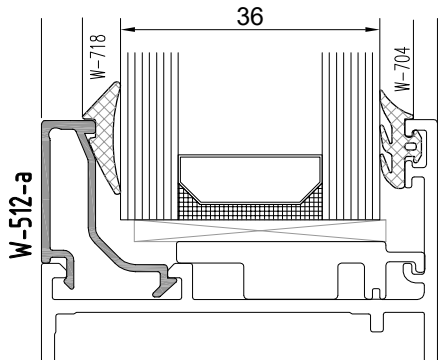
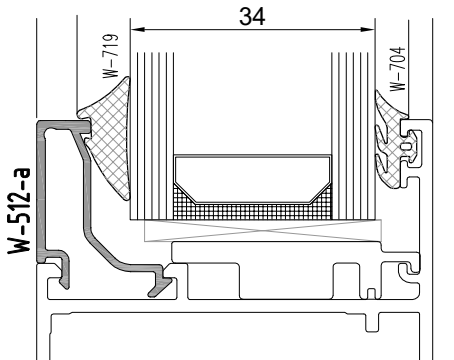
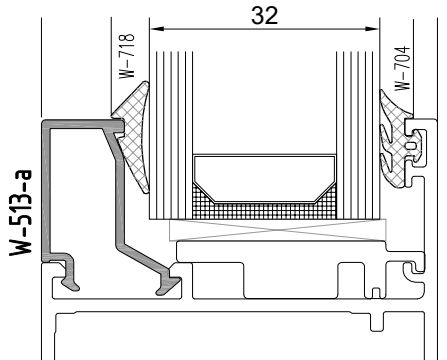
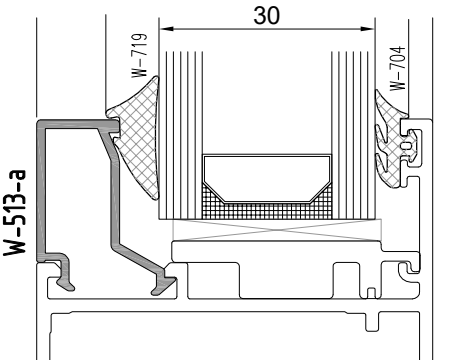
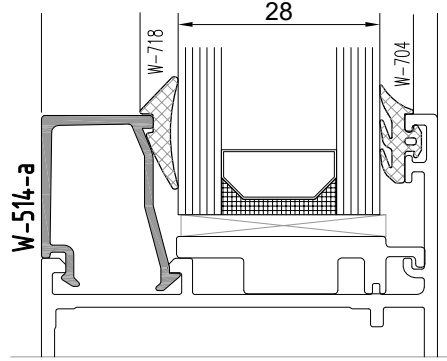
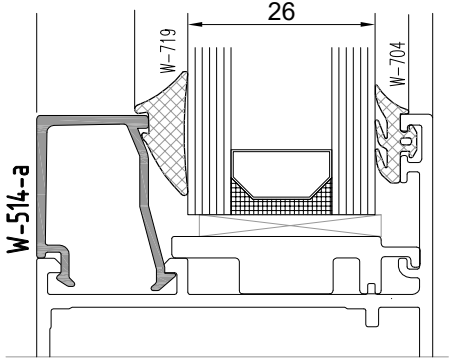
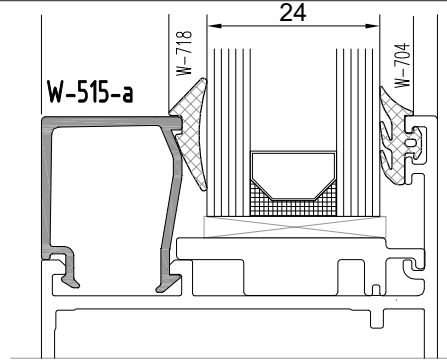
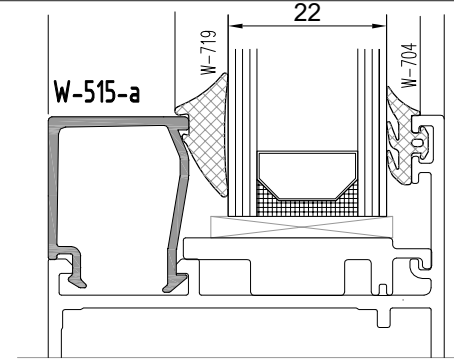

Profil değerleri teoriktir. Ağırlık olarak testimde yapılan tartım geçerlidir.
Profil imatları TS EN 12020-2 ve TS EN 755-9 toleransı,
Moment değerleri EN 14024'e göre hesaplanmıştır.

Profile values are theoretical pre-shipment weight will be valid.
The tolerances of Profile manufacturing are calculated according to EN 12020-2
and TS EN 755-9; moment values are calculated according to EN 14024.

D2
D 55 YALITIMSIZ KAPI PROFİLLERİ
D55 NONINSULATED SERIES

ÜRÜN TEKNİK ÖZELLİKLERİ
PRODUCT'S TECHNICAL FEATURES

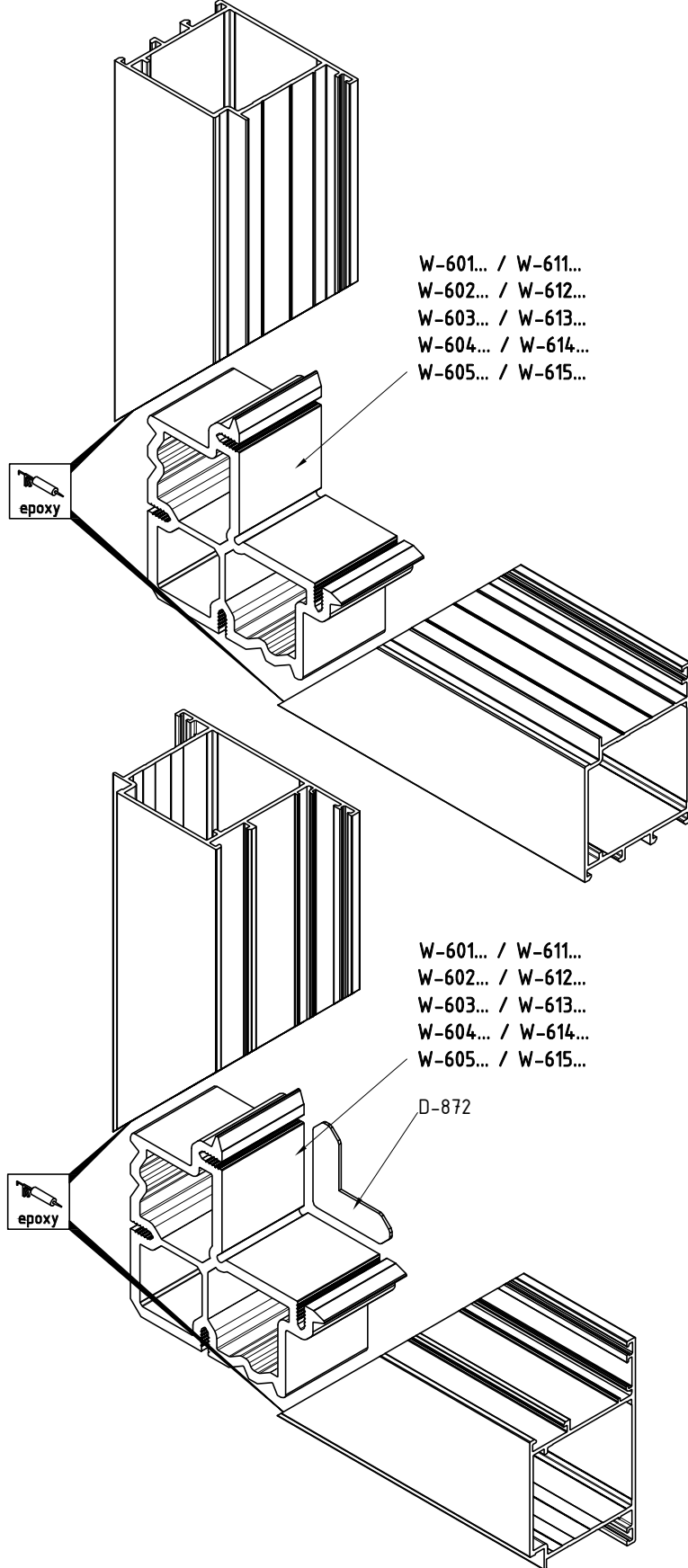

D2
D 55 YALITIMSIZ KAPI PROFİLLERİ
D55 NONINSULATED SERIES

ÜRÜN TEKNİK ÖZELLİKLERİ
PRODUCT'S TECHNICAL FEATURES

Profil No : W-603
Ağırlık : 4871 gr/m

Profil No : W-613
Ağırlık : 3945 gr/m

W-603-a	W-613-a	8.2mm	50 adet/pcs
W-603-b	W-613-b	23.6mm	50 adet/pcs
W-603-c	W-613-c	6mm	50 adet/pcs
W-603-d	W-613-d	25.3mm	50 adet/pcs
W-603-e	W-613-e	50.1mm	50 adet/pcs
W-603-f	W-613-f	5.3mm	50 adet/pcs
W-603-g	W-613-g	4.7mm	50 adet/pcs
W-603-h	W-613-h	7.5mm	50 adet/pcs
W-603-ı	W-613-ı	41.8mm	50 adet/pcs

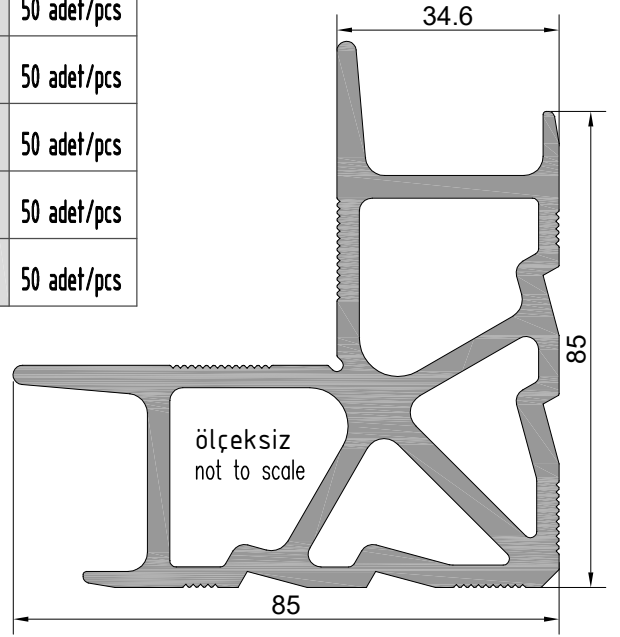
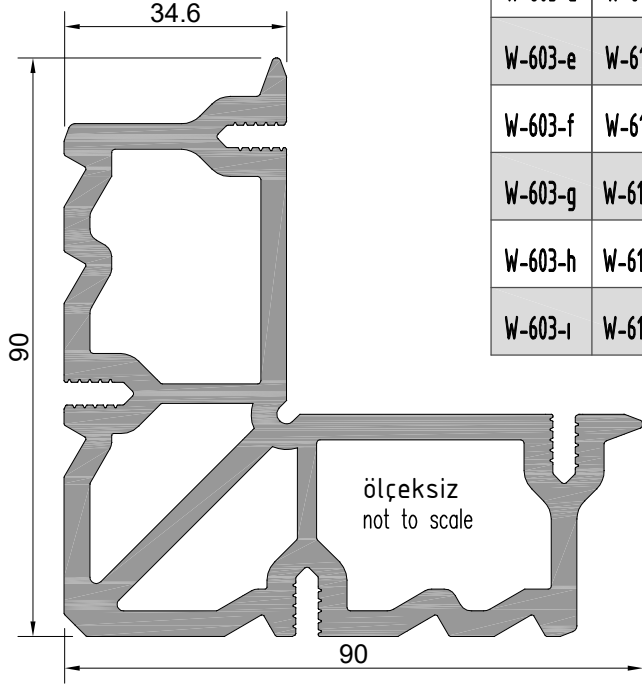

Profil No : W-604
Ağırlık : 5539 gr/m

W-604-a	W-614-a	6mm	25 adet/pcs	W-604-h	W-614-h	20mm	25 adet/pcs
W-604-b	W-614-b	25.3mm	25 adet/pcs	W-604-ı	W-614-ı	5.3mm	25 adet/pcs
W-604-c	W-614-c	23.4mm	25 adet/pcs	W-604-j	W-614-j	43.3mm	25 adet/pcs
W-604-d	W-614-d	14mm	25 adet/pcs	W-604-k	W-614-k	7.5mm	25 adet/pcs
W-604-e	W-614-e	50.1mm	25 adet/pcs	W-604-l	W-614-l	18.6mm	25 adet/pcs
W-604-f	W-614-f	50.6mm	25 adet/pcs	W-604-m	W-614-m	11.9mm	25 adet/pcs
W-604-g	W-614-g	42.1mm	25 adet/pcs	W-604-n	W-614-n	41.8mm	25 adet/pcs
				W-604-o	W-614-o	8.5mm	25 adet/pcs

Profil No : W-614
Ağırlık : 5318 gr/m

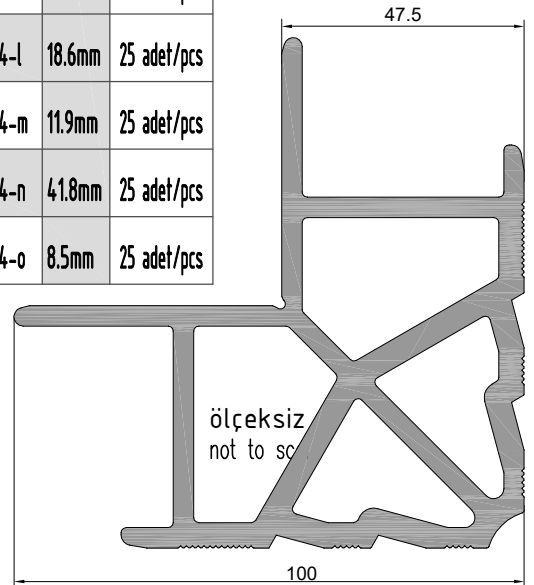
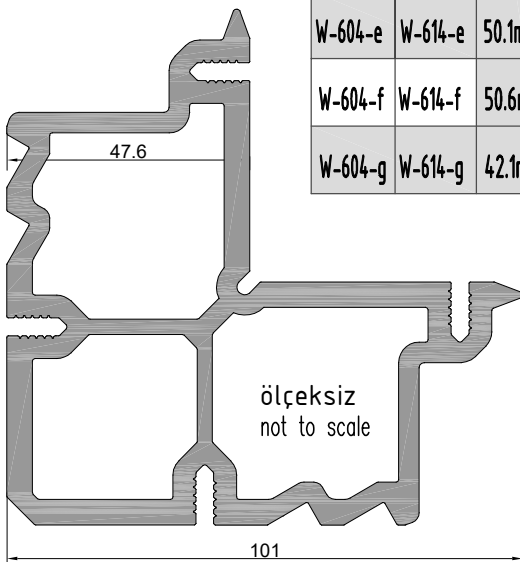

D2
D 55 YALITIMSIZ KAPI PROFİLLERİ
D55 NONINSULATED SERIES

ÜRÜN TEKNİK ÖZELLİKLERİ
PRODUCT'S TECHNICAL FEATURES

W-609-a	W-609\2-a	W-610-a	14.6mm	100 adet/pcs
W-609-b	W-609\2-b	W-610-b	24.6mm	100 adet/pcs
W-609-c	W-609\2-c	W-610-c	34.6mm	100 adet/pcs
W-609-d	W-609\2-d	W-610-d	55.6mm	100 adet/pcs
W-609-e	W-609\2-e	W-610-e	80.3mm	100 adet/pcs
W-609-f	W-609\2-f	W-610-f	110.6mm	100 adet/pcs
W-609-g	W-609\2-g	W-610-g	19.6mm	100 adet/pcs

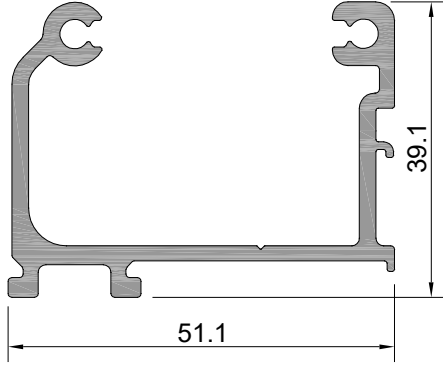

Profil No: W-610
Ağırlık : 938 gr/m

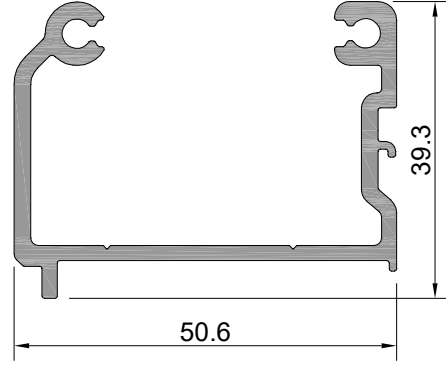

Profil No: W-609
Ağırlık : 867 gr/m

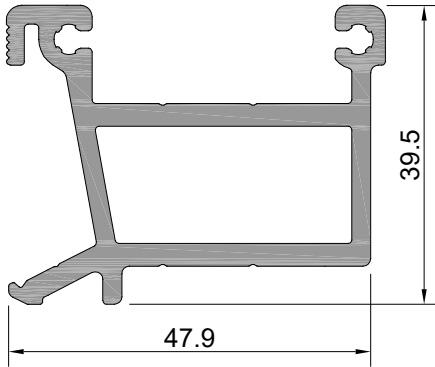

Profil No: W-609\2 ⚠
Ağırlık : 1306 gr/m

⚠ İşaretti profil için satış ekibinden bilgi alınız.

D2
D 55 YALITIMSIZ KAPI PROFİLLERİ
D55 NONINSULATED SERIES

ÜRÜN TEKNİK ÖZELLİKLERİ
PRODUCT'S TECHNICAL FEATURES

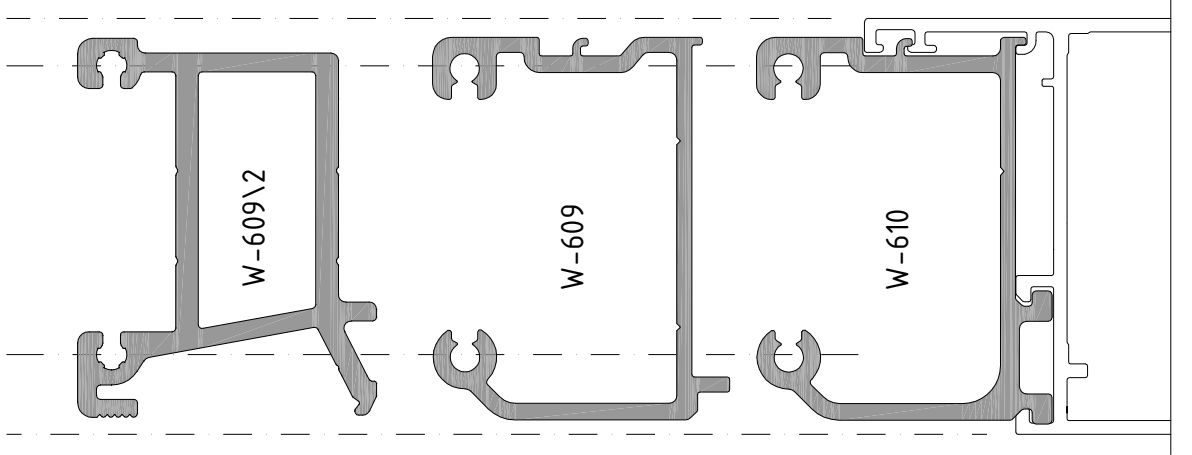
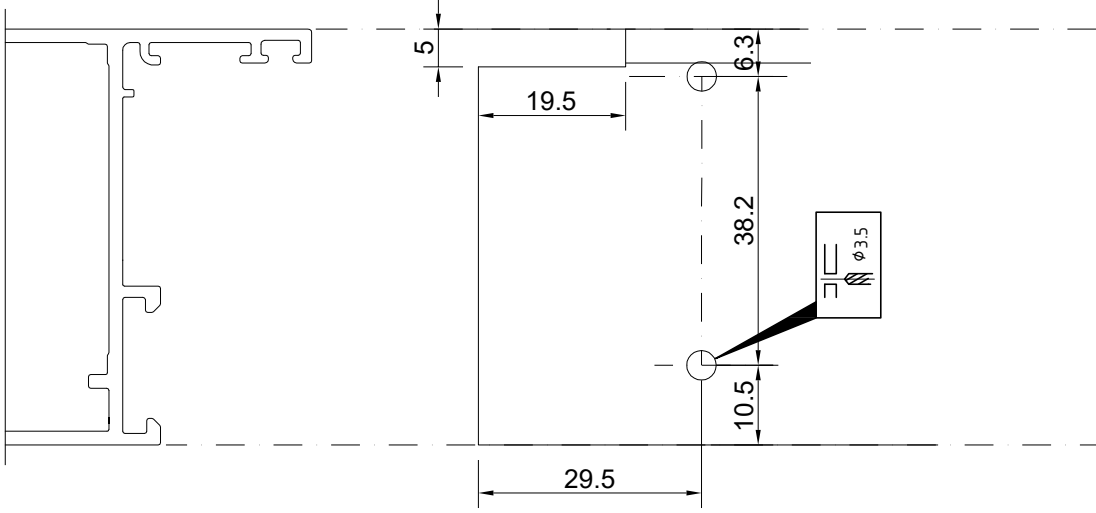

ALTERNATİF 3
ALTERNATIVE 3

ALTERNATİF 1
ALTERNATIVE 1

ALTERNATİF 2
ALTERNATIVE 2

D2
WD55-1.6 T YALITIMSIZ KAPI SERİSİ
 D55-NONINSULATED SERIES

YAN BİTİM-KANAT BİRLEŞİM DETAYI
 WALL CONNECTION-CASEMENT JOINING DETAIL

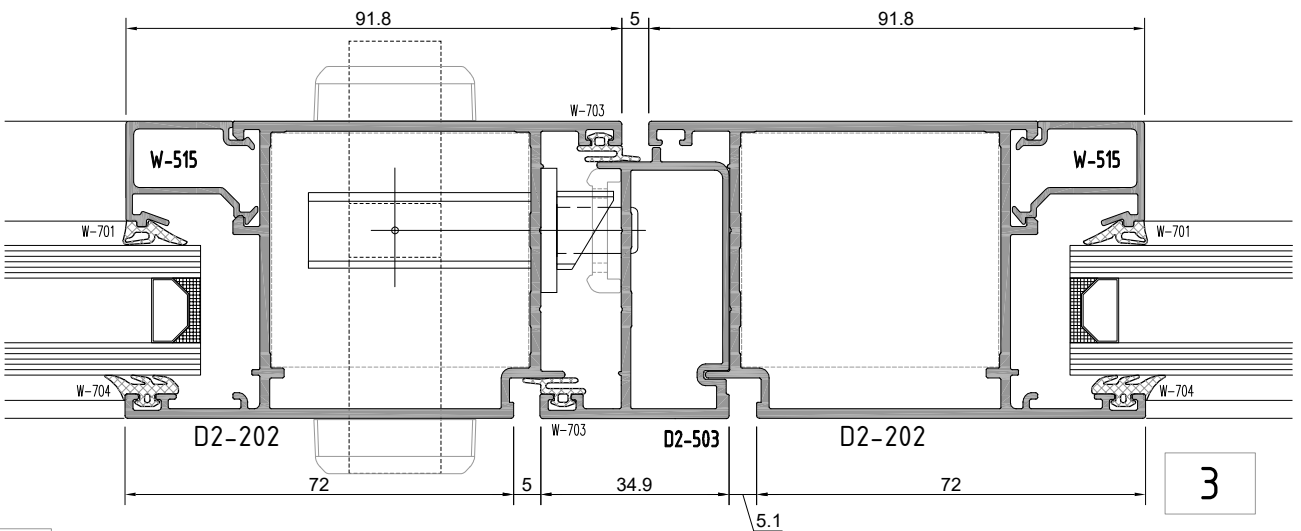
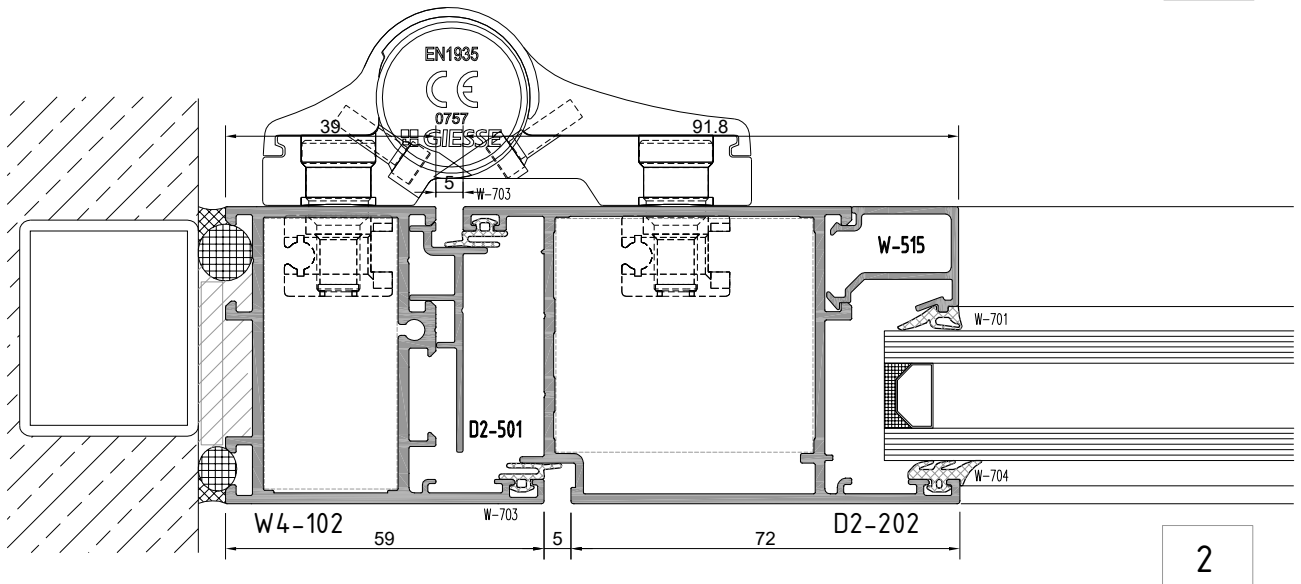
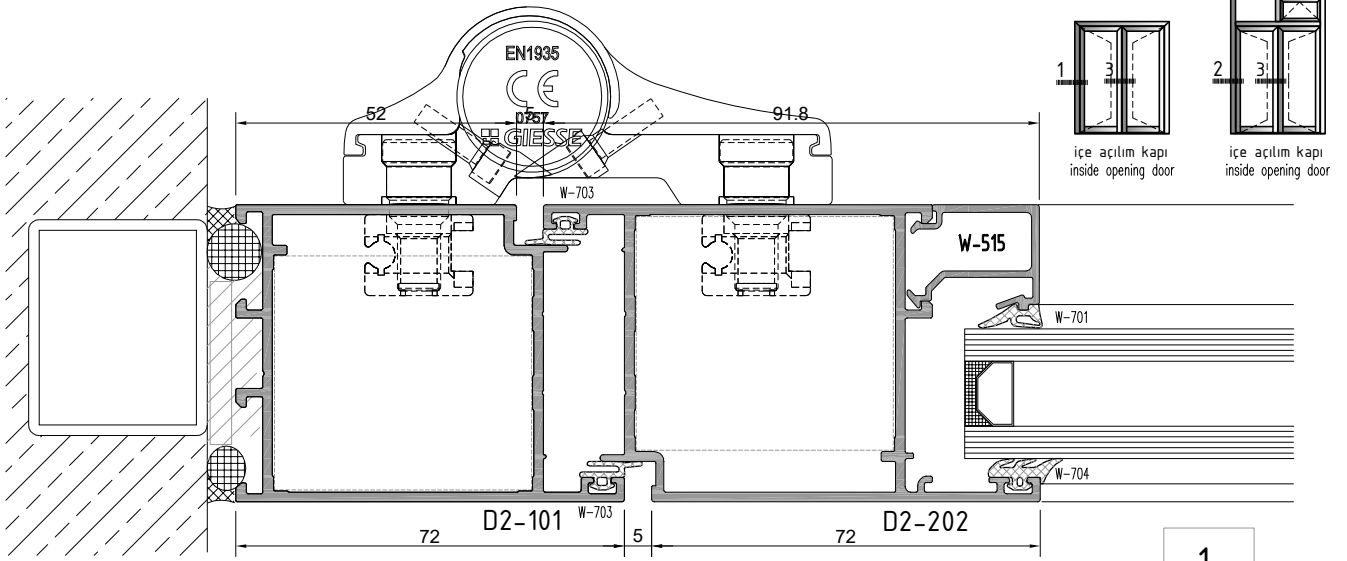

not to scale

D2

WD55-1.6 T YALITIMSIZ KAPI SERİSİ
D55-NONINSULATED SERIES

ÜST BİTİM-ORTA KAYIT DETAYI
TOP EDGE-MULLION DETAIL

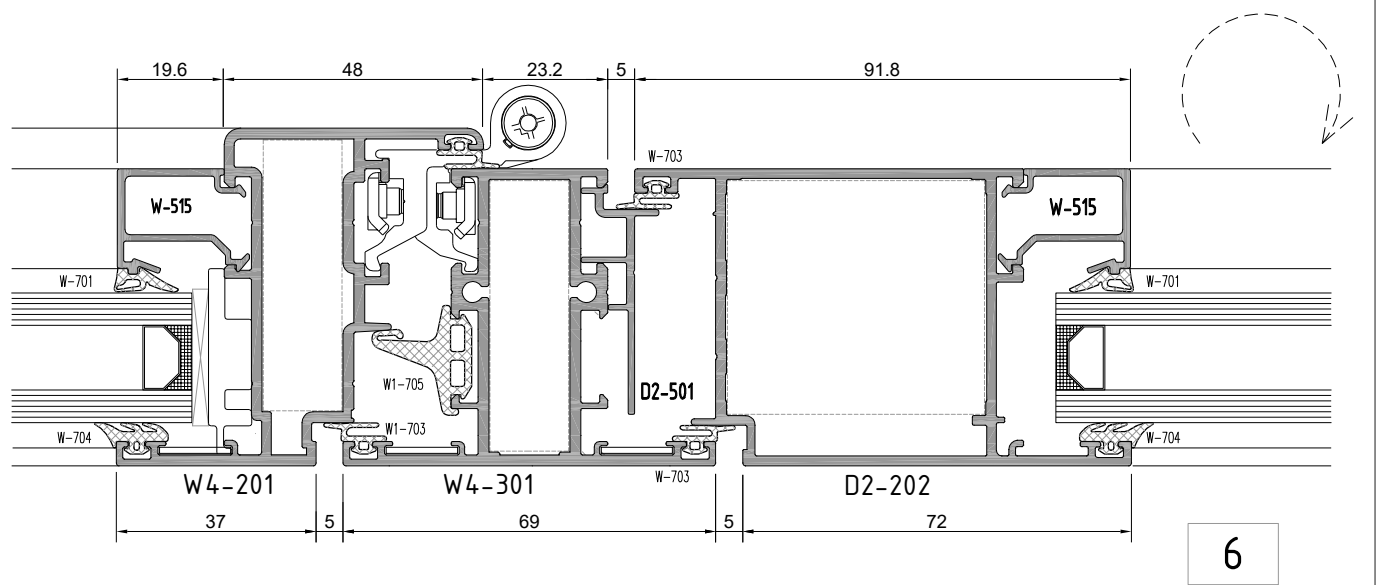
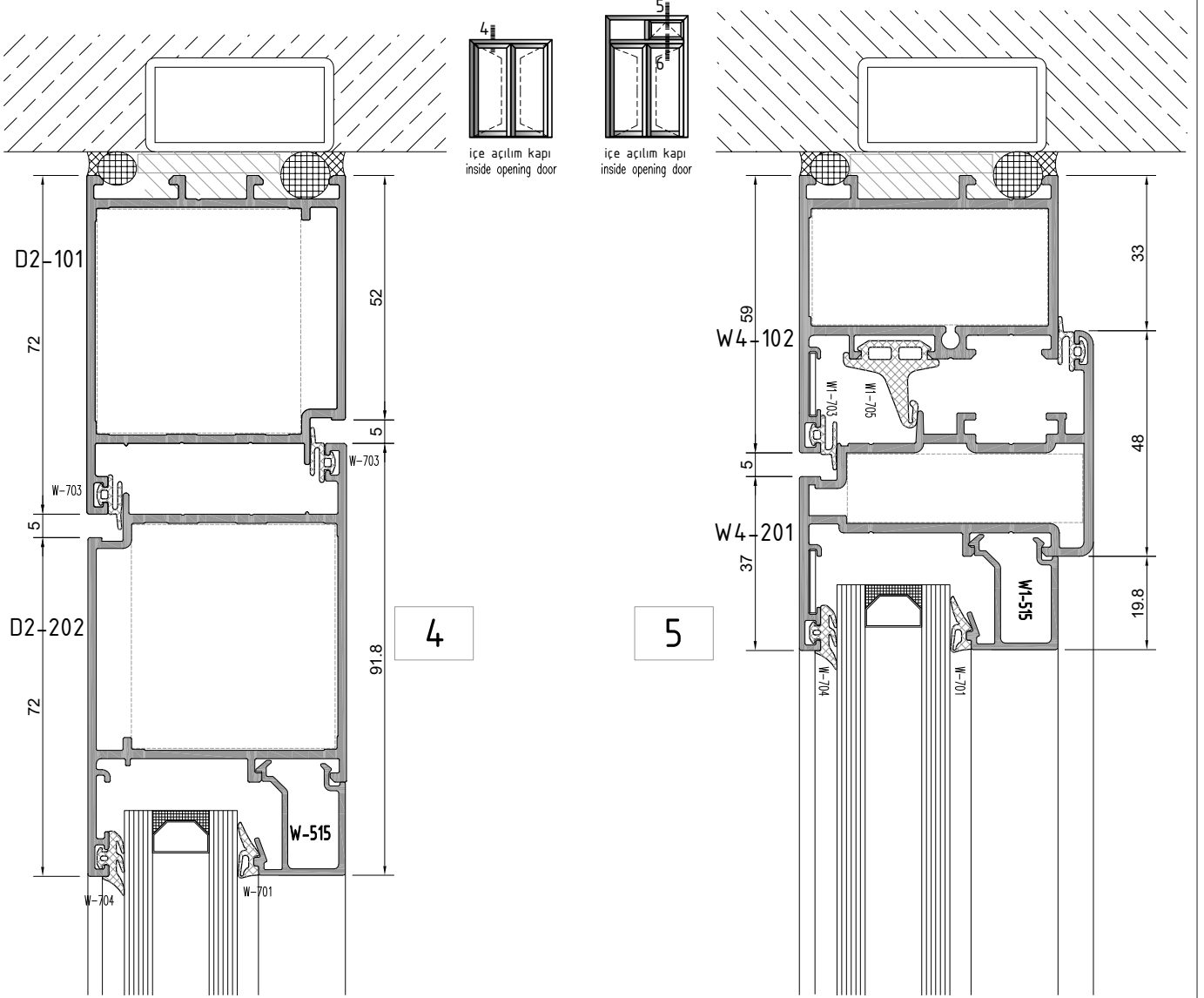

not to scale

6

D2
WD55-1.6 T YALITIMSIZ KAPI SERİSİ
D55-NONINSULATED SERIES

ALT BİTİM DETAYI
BOTTOM EDGE - DETAIL

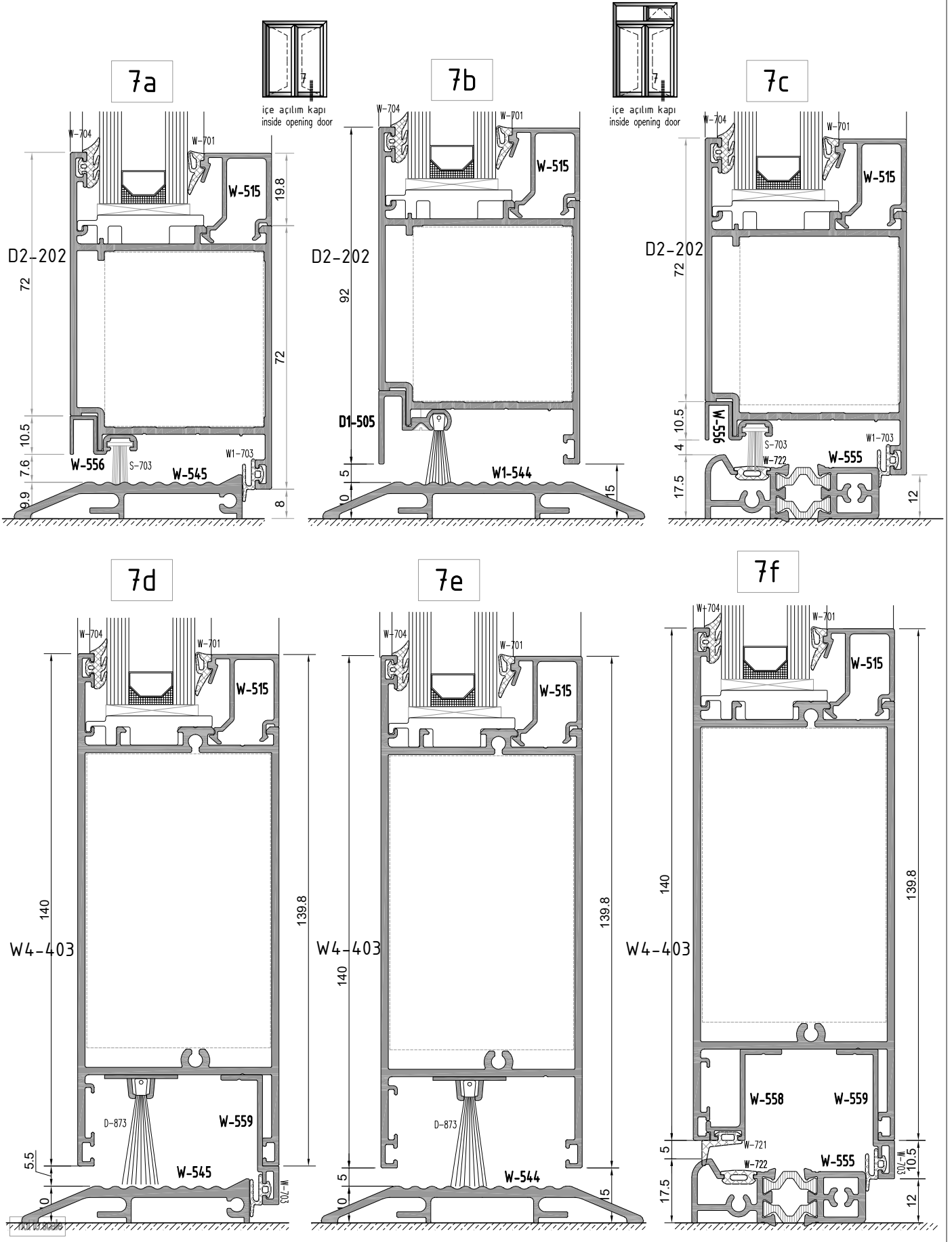

D2

WD55-1.6 T YALITIMSIZ KAPI SERİSİ
D55-NONINSULATED SERIES

YAN BİTİM-KANAT BİRLEŞİM DETAYI
WALL CONNECTION-CASEMENT JOINING DETAIL

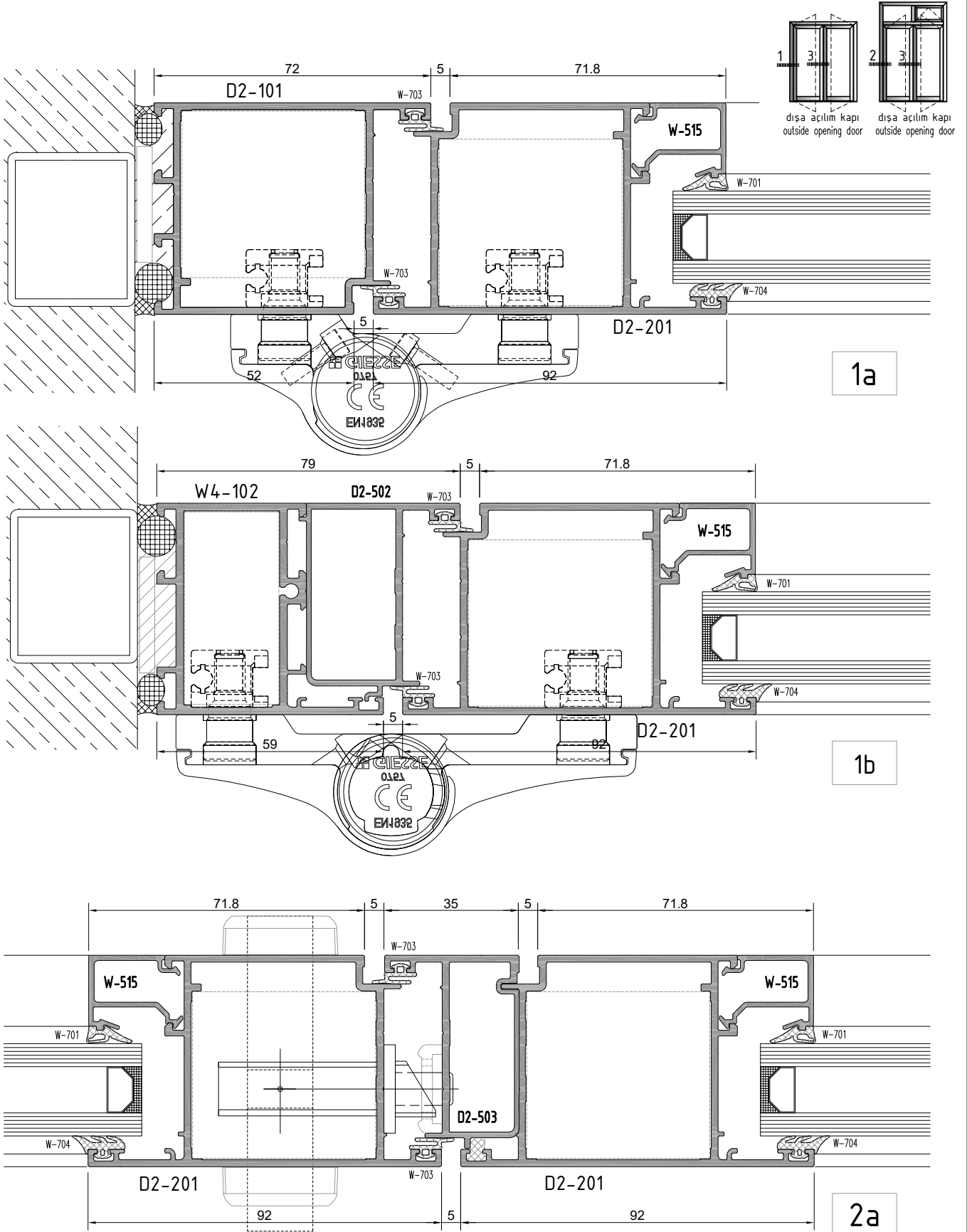

1a

1b

2a

not to scale

D2

WD55-1.6 T YALITIMSIZ KAPI SERİSİ
D55-NONINSULATED SERIES

ÜST BİTİM-ORTA KAYIT DETAYI
TOP EDGE-MULLION DETAIL

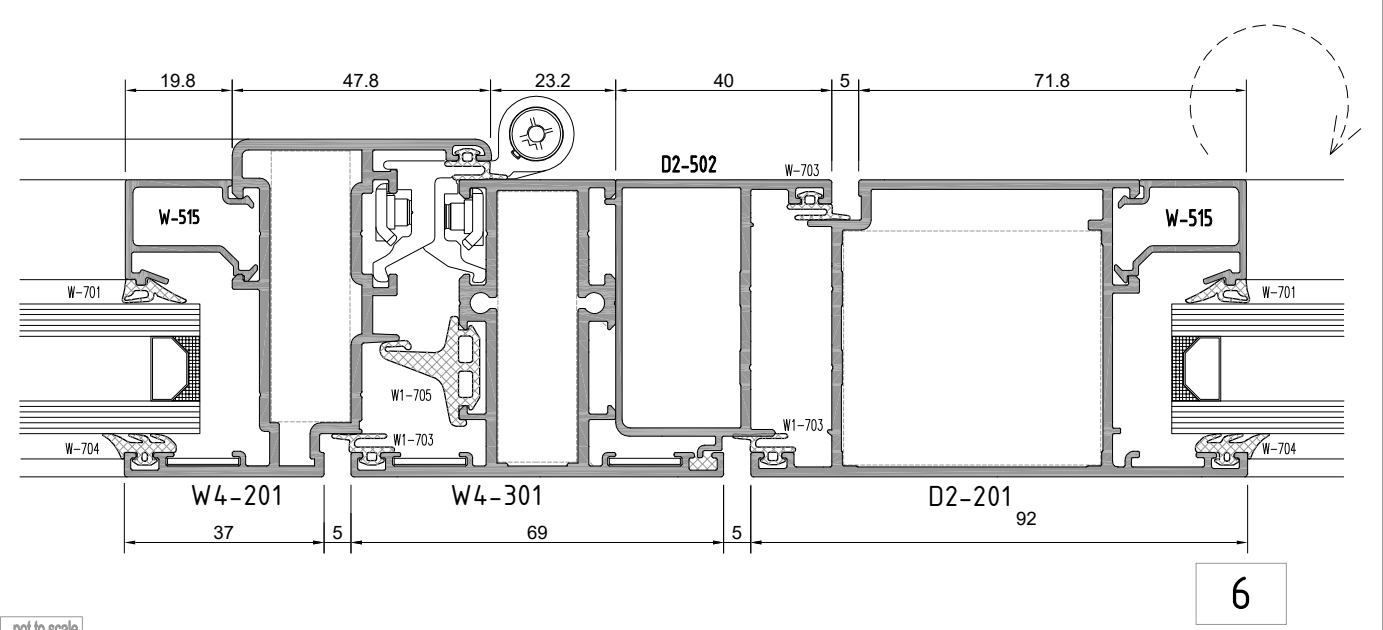
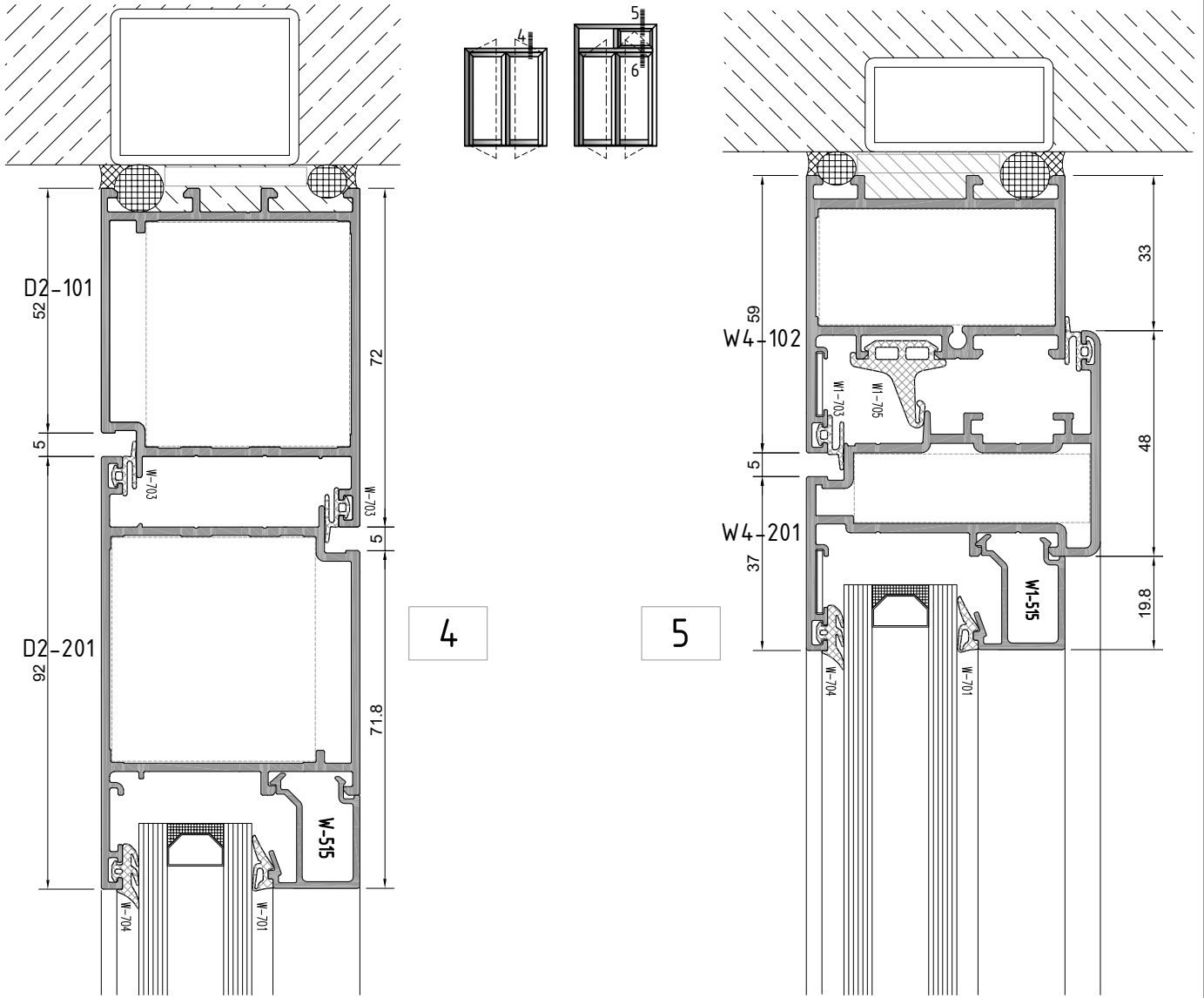

not to scale

D2

WD55-1.6 T YALITIMSIZ KAPI SERİSİ
D55-NONINSULATED SERIES

ALT BİTİM DETAYI
BOTTOM EDGE - DETAIL

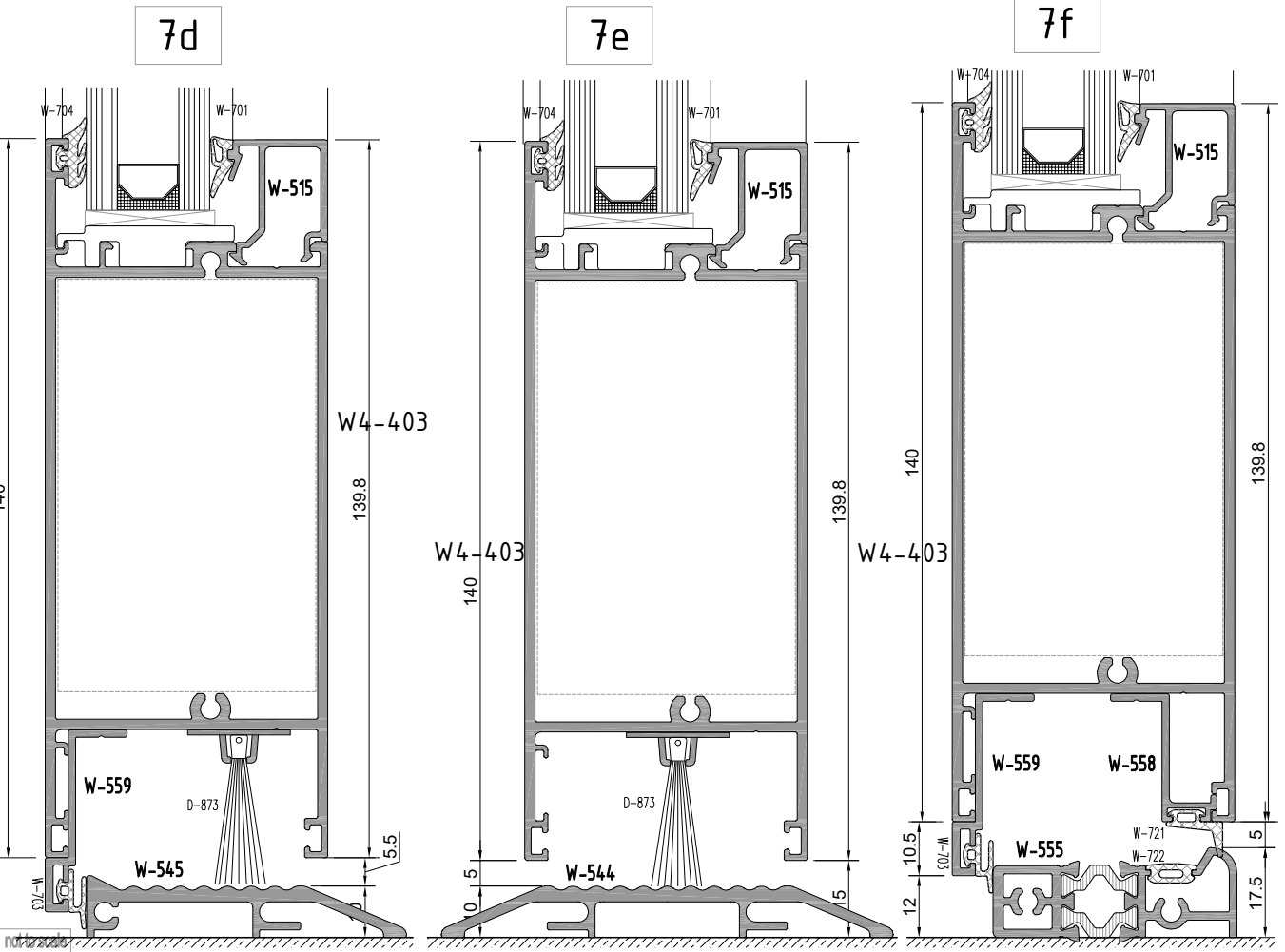
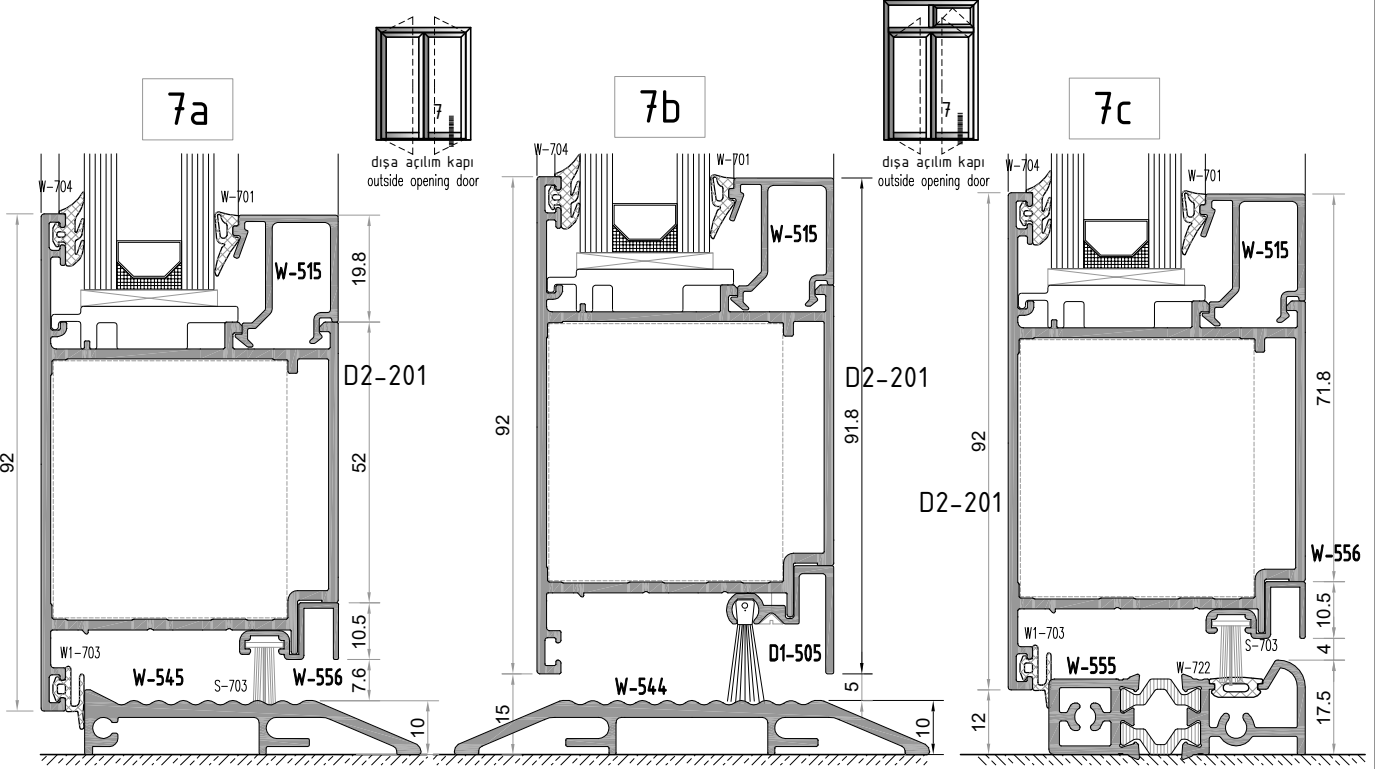

D2
WD55-1.6 T YALITIMSIZ KAPI SERİSİ
D55-NONINSULATED SERIES

CEPHE BİRLEŞİM DETAYI
FACADE SYSTEM MERGE DETAIL

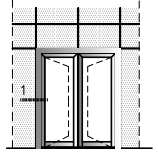

içe açılım kapı
inside opening door

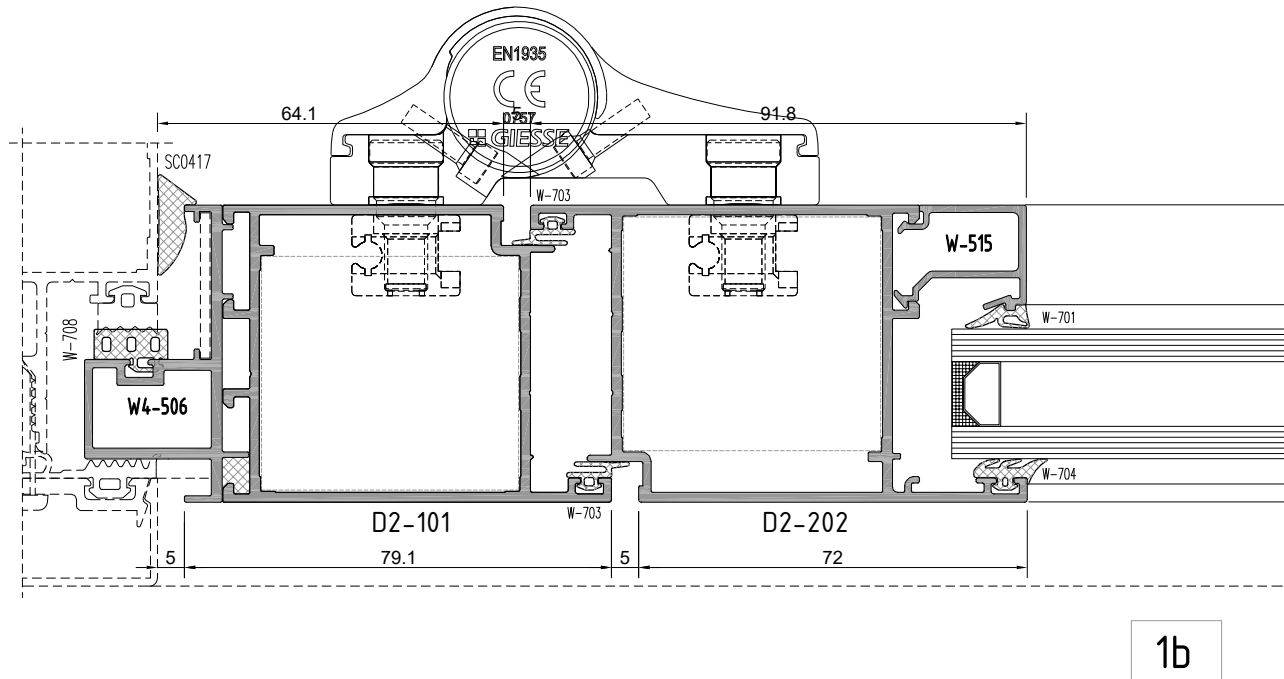
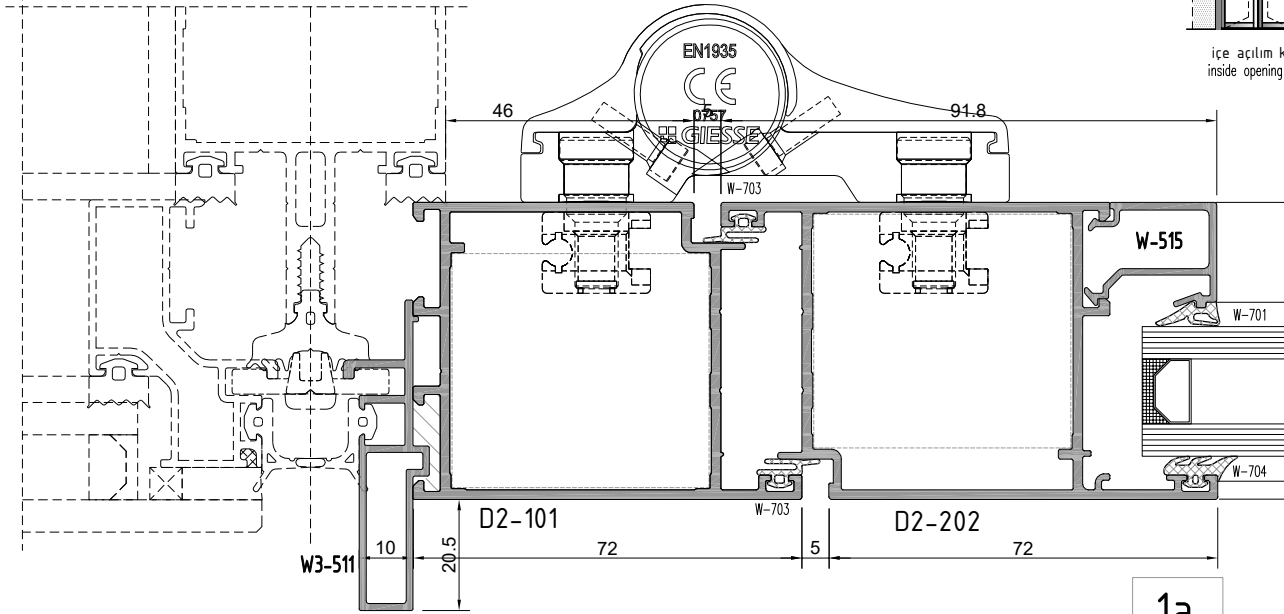

D2

WD55-1.6 T YALITIMSIZ KAPI SERİSİ
D55-NONINSULATED SERIES

CEPHE BİRLEŞİM DETAYI
FACADE SYSTEM MERGE DETAIL

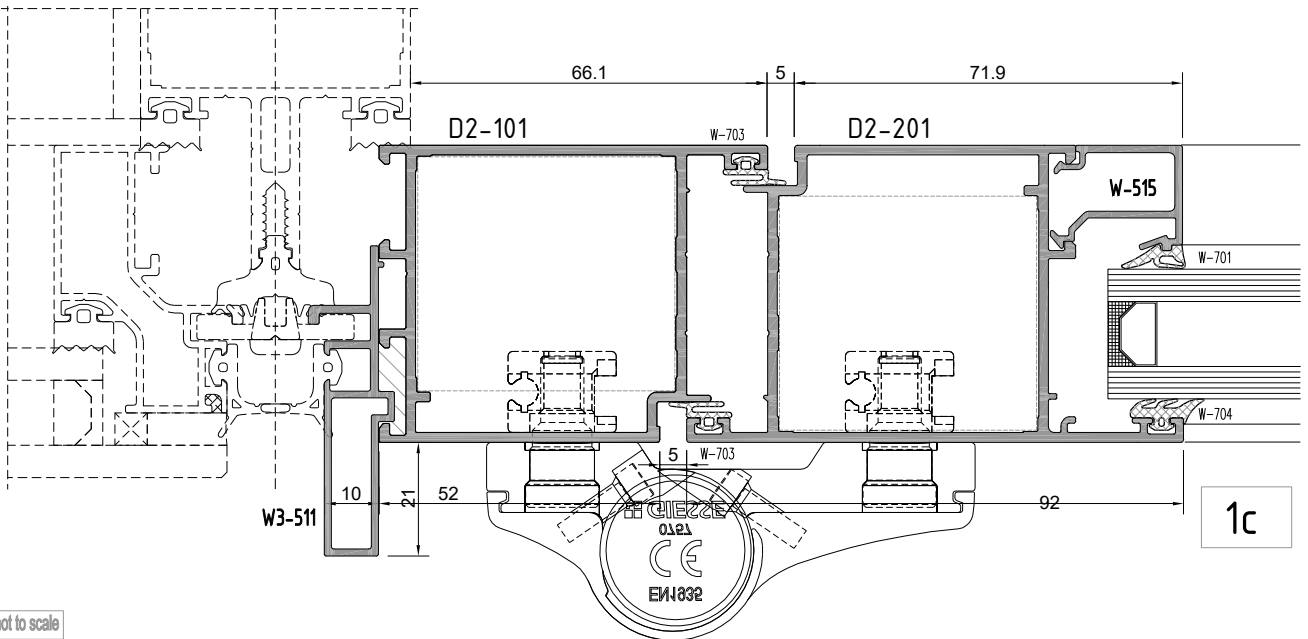
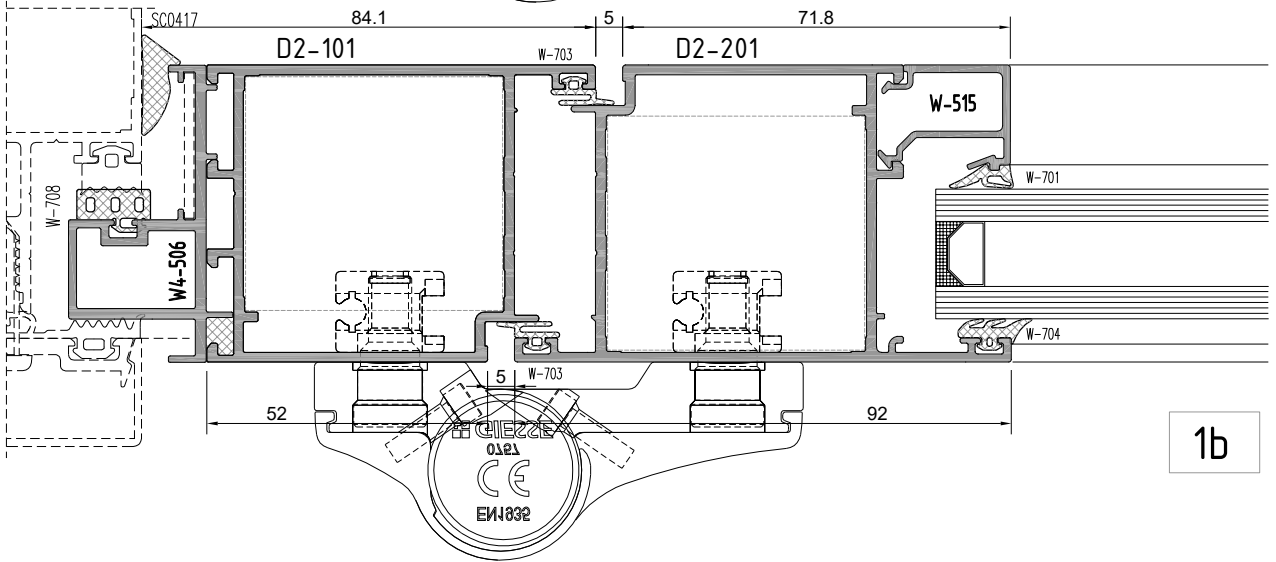
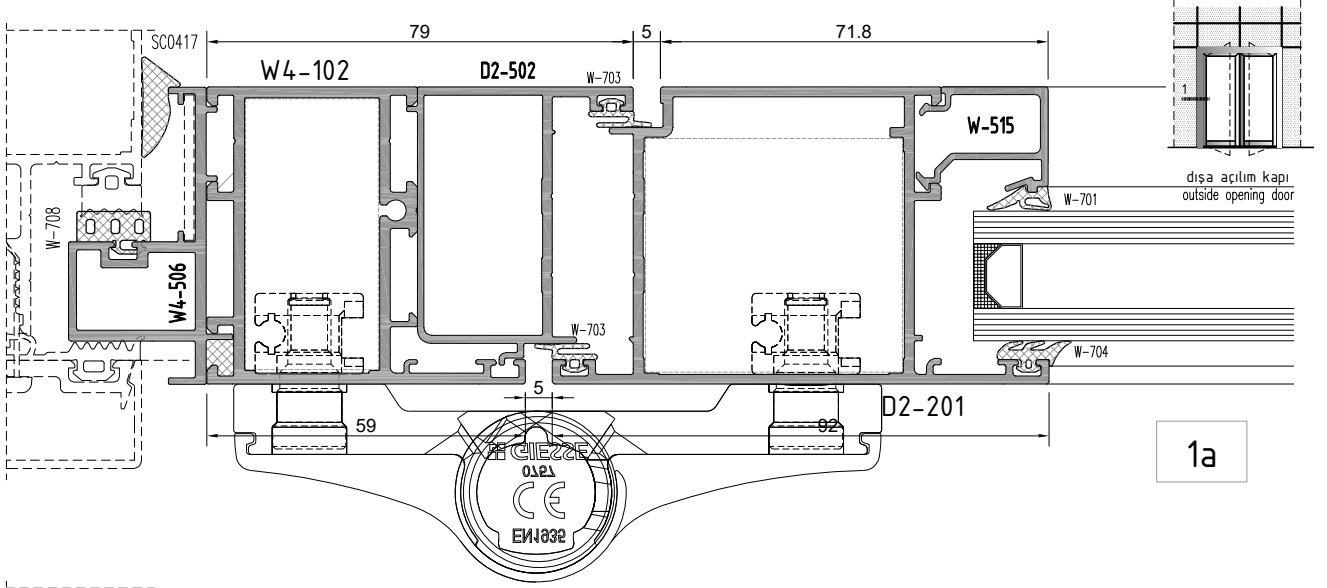

not to scale

D2
D 55 YALITIMSIZ KAPI SERİSİ
D 55 NONINSULATED SERIES

İMALAT ŞEMASI
PRODUCTION PLAN

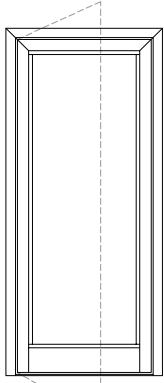

İCERİ ACILAN KAPI
INSIDE OPENING DOOR

$KX = L - 114$
$KY = H - 72$
$G = B + 28$

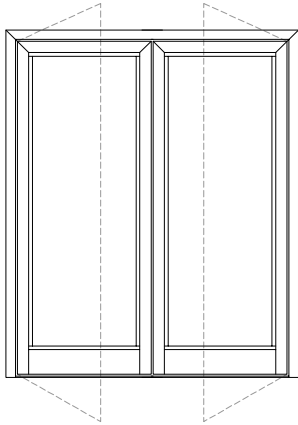
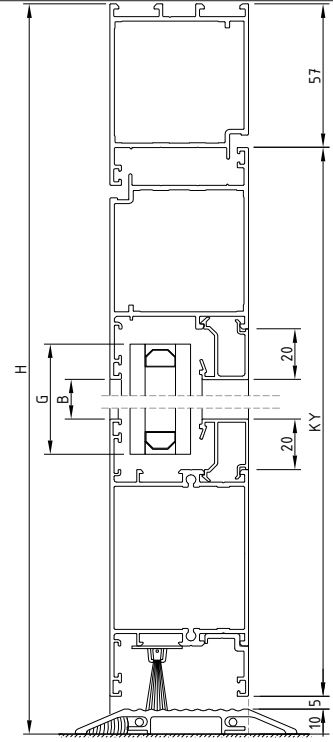
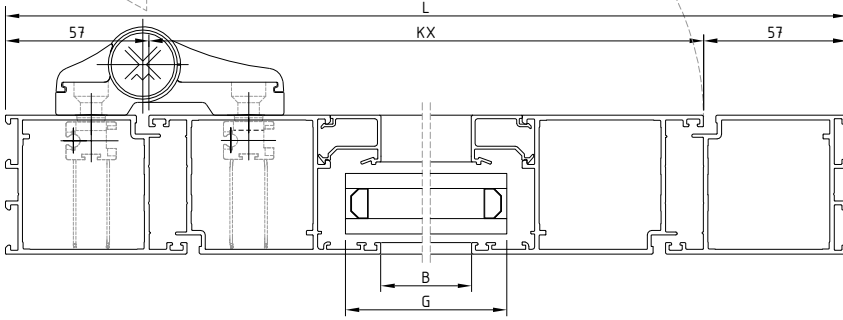

ÇİFT KANAT İCERİ ACILAN KAPI
DOUBLE INSIDE OPENING DOOR

$KX = \frac{L - 114 - 5}{2}$
$KY = H - 72$
$G = B + 28$

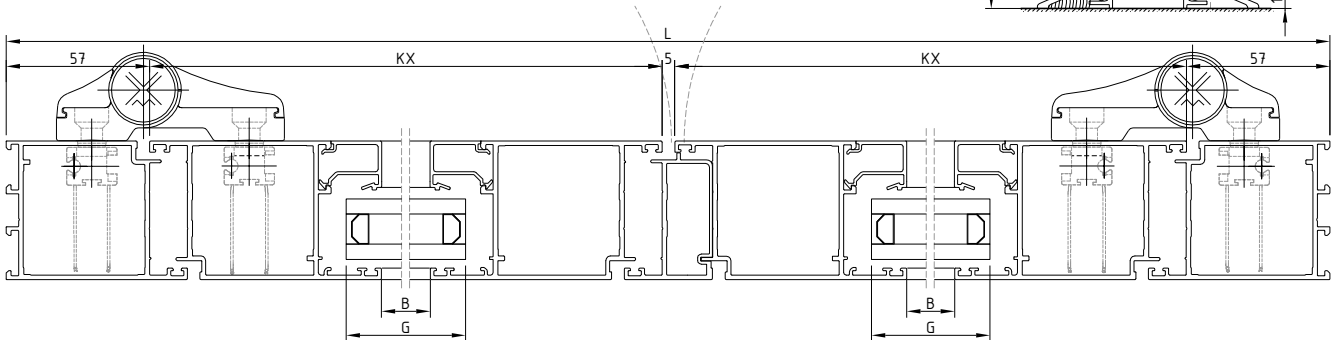
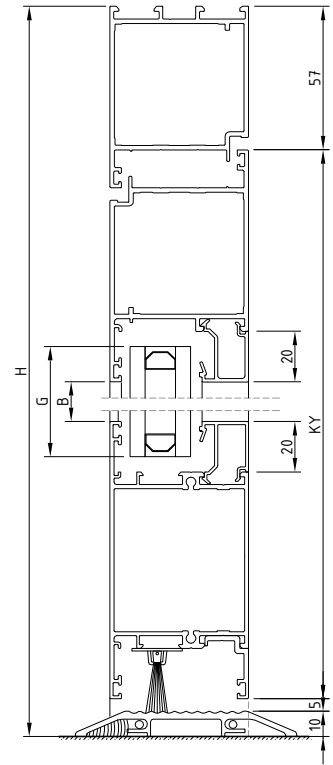

D2
D 55 YALITIMSIZ KAPI SERİSİ
D 55 NONINSULATED SERIES

İMALAT ŞEMASI
PRODUCTION PLAN

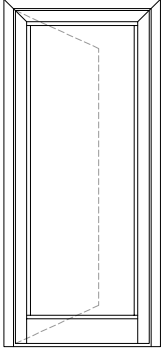

DIŞA AÇILAN KAPI
OUTSIDE OPENING DOOR

$$KX = L - 114$$

$$KY = H - 72$$

$$G = B + 28$$

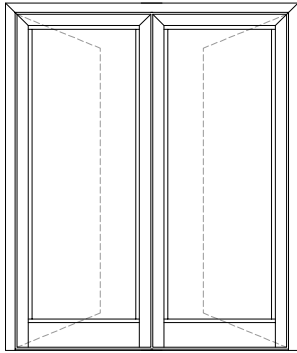
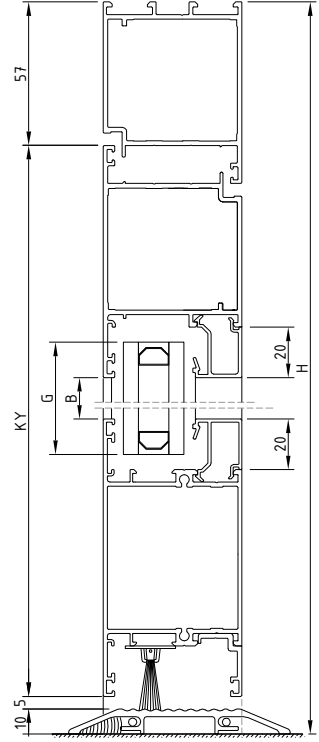
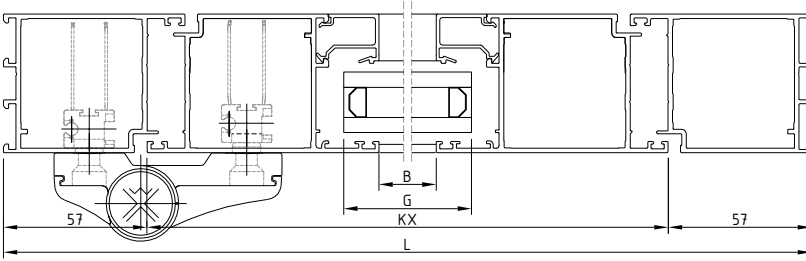

ÇİFT KANAT DIŞARI AÇILAN KAPI
DOUBLE OUTSIDE OPENING DOOR

$$KX = \frac{L - 114 - 5}{2}$$

$$KY = H - 72$$

$$G = B + 28$$

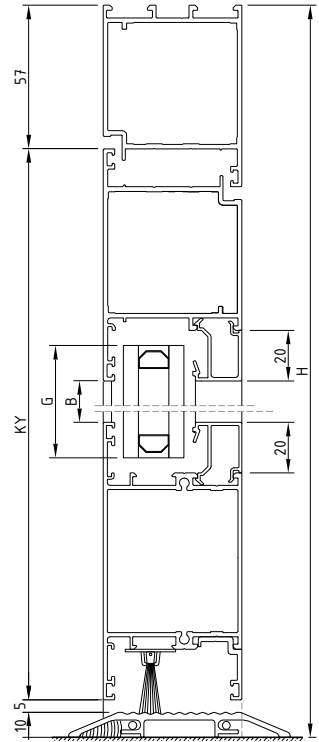
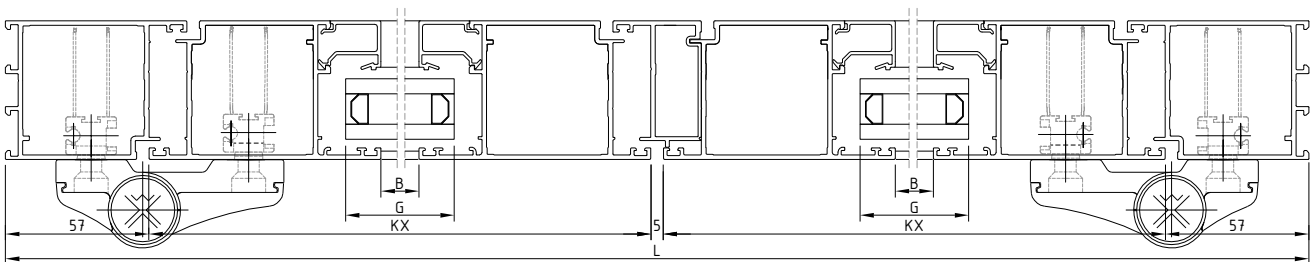

D 55 SERİ PROFİLLERİ

D55 PROFILES SERIE

FİTİL LİSTESİ

Gasket list

kod code	şekil drawing	tanım description	teorik ağırlık teoretical weight gr / m	paket ağırlığı package weight kg / package	paket metrajı in one package metre / package	kullanım yeri aplication
W-701		epdm cam iç fitil glazing gasket inside	41 gr/m	15 kg	366 m	
W-702		epdm cam iç fitil glazing gasket inside	49 gr/m	15 kg	306 m	
W-703		epdm çarpma iç-dış fitil glazing acoustical (epdm)	33 gr/m	15 kg	440 m	
W-704		epdm cam dış fitil glazing gasket outside (epdm)	50 gr/m	15 kg	300 m	
W-707		epdm etek fitili gasket under profile	58 gr/m	15.0 kg	258 m	
W-708		Profil iç fitil Profile gasket inside	91 gr/m	15 kg	165 m	
W-709		profil ara fitil gasket between profile (epdm)	82 gr/m	15 kg	183 m	

D 55 SERİ PROFİLLERİ

D55 PROFILES SERIE

Fıtıl listesi

Gasket list

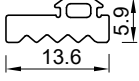
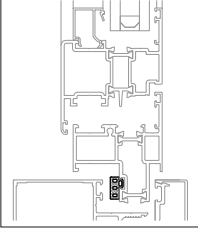
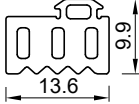
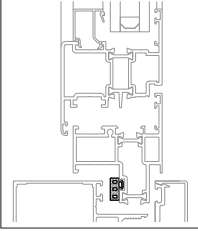
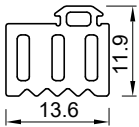
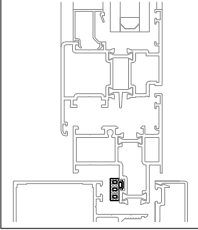
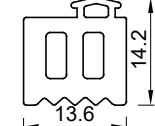
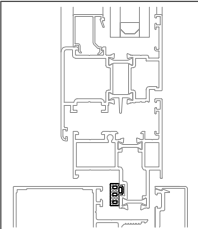
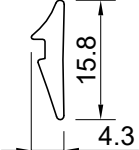
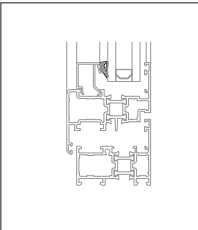
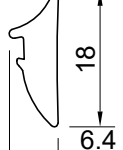
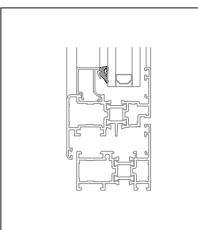
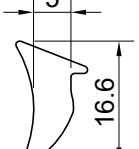
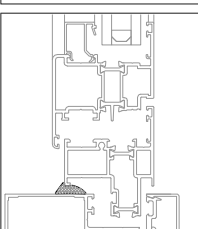
kod code	şekil drawing	tanım description	teorik ağırlık theoretical weight gr / m	paket ağırlığı package weight kg / package	paket metrajı in one package metre / package	kullanım yeri aplication
W-711		Profil iç fitil Profile gasket inside	65 gr/m	15 kg	230 m	
W-712		Profil iç fitil Profile gasket inside	110 gr/m	15 kg	135 m	
W-713		Profil iç fitil Profile gasket inside	135 gr/m	15 kg	110 m	
W-714		Profil iç fitil Profile gasket inside	166 gr/m	15 kg	90 m	
W-718		epdm cam iç fitil glazing gasket inside	52 gr/m	15 kg	288 m	
W-719		epdm cam iç fitil glazing gasket inside	88 gr/m	15 kg	170 m	
SC0417		kasa alt fitil safe gasket inside (epdm)	96 gr/m	15 kg	156 m	

D 55 SERİ PROFİLLERİ

D55 PROFILES SERIE

Fitil listesi
Gasket list

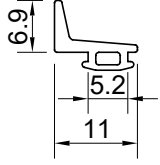
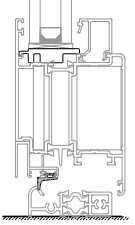
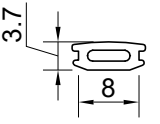
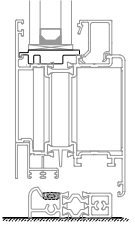
kod code	şekil drawing	tanım description	teorik ağırlık theoretical weight gr / m	paket ağırlığı package weight kg / package	paket metraji in one package metre / package	kullanım yeri aplication
W-721		Eşik Fitili gasket threshold profile	40 gr/m	15 kg	375 m	
W-722		Eşik Fitili gasket threshold profile	30 gr/m	15 kg	500 m	

AKSESUARLAR ACCESSOIRES

PENCERE VE KAPI AÇILIM MEKANİZMALARI WINDOW AND DOOR OPENING MECHANISMS

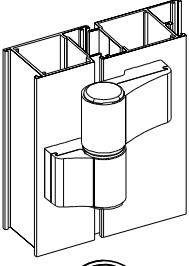

İki yapraklı kapı menteşesi
Two-leaf hinges for door

- | | | |
|---------------------------|-----------------------------|---|
| D-800 (ithal)
(import) | D-800-a (yerli)
(native) | naturel eloksalli
(mat anodized) |
| D-801 (ithal)
(import) | D-801-a (yerli)
(native) | pres veya renkli
(mill finish and painted) |

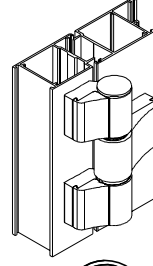

Üç yapraklı kapı menteşesi
Three-leaf hinges for door

- | | | |
|---------------------------|-----------------------------|---|
| D-803 (ithal)
(import) | D-803-a (yerli)
(native) | naturel eloksalli
(mat anodized) |
| D-804 (ithal)
(import) | D-804-a (yerli)
(native) | pres veya renkli
(mill finish and painted) |

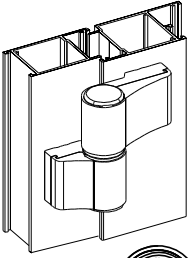
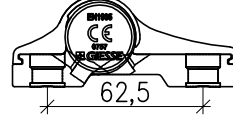

İki yapraklı kapı menteşesi
Two-leaf hinges for door

- | | | |
|---------------------------|-----------------------------|---|
| D-806 (ithal)
(import) | D-806-a (yerli)
(native) | naturel eloksalli
(mat anodized) |
| D-807 (ithal)
(import) | D-807-a (yerli)
(native) | pres veya renkli
(mill finish and painted) |

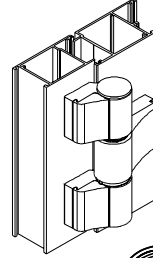
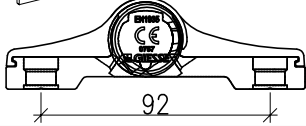

Üç yapraklı kapı menteşesi
Three-leaf hinges for door

- | | | |
|---------------------------|-----------------------------|---|
| D-809 (ithal)
(import) | D-809-a (yerli)
(native) | naturel eloksalli
(mat anodized) |
| D-810 (ithal)
(import) | D-810-a (yerli)
(native) | pres veya renkli
(mill finish and painted) |



Menteşe kademe yükseltici
Step for hinges

- | | | |
|---------------------------|-----------------------------|---|
| D-888 (ithal)
(import) | D-888-a (yerli)
(native) | naturel eloksalli
(mat anodized) |
| D-889 (ithal)
(import) | D-889-a (yerli)
(native) | pres veya renkli
(mill finish and painted) |

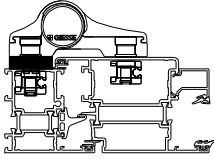

Menteşe kademe yükseltici
Step for hinges

- | | | |
|---------------------------|-----------------------------|---|
| D-890 (ithal)
(import) | D-890-a (yerli)
(native) | naturel eloksalli
(mat anodized) |
| D-891 (ithal)
(import) | D-891-a (yerli)
(native) | pres veya renkli
(mill finish and painted) |

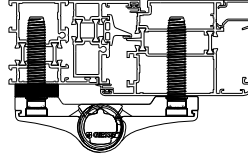

İki yapraklı kapı menteşesi için bağlantı takımı
Two-leaf hinges door for counterplates

- | | | |
|---------------------------|-----------------------------|-------------------------------------|
| D-892 (ithal)
(import) | D-892-a (yerli)
(native) | naturel eloksalli
(mat anodized) |
|---------------------------|-----------------------------|-------------------------------------|

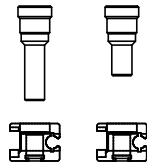
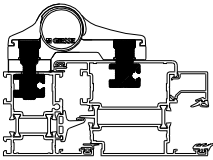

İki yapraklı kapı menteşesi için bağlantı takımı
Two-leaf hinges door for counterplates

- | | | |
|---------------------------|-----------------------------|-------------------------------------|
| D-893 (ithal)
(import) | D-893-a (yerli)
(native) | naturel eloksalli
(mat anodized) |
|---------------------------|-----------------------------|-------------------------------------|

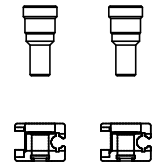
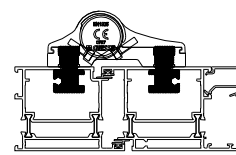

Üç yapraklı kapı menteşesi için bağlantı takımı
Three-leaf hinges door for counterplates

- | | | |
|---------------------------|-----------------------------|-------------------------------------|
| D-894 (ithal)
(import) | D-894-a (yerli)
(native) | naturel eloksalli
(mat anodized) |
|---------------------------|-----------------------------|-------------------------------------|

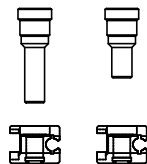
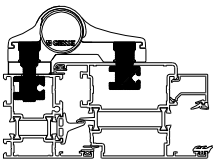

Üç yapraklı kapı menteşesi için bağlantı takımı
Three-leaf hinges door for counterplates

- | | | |
|---------------------------|-----------------------------|-------------------------------------|
| D-895 (ithal)
(import) | D-895-a (yerli)
(native) | naturel eloksalli
(mat anodized) |
|---------------------------|-----------------------------|-------------------------------------|

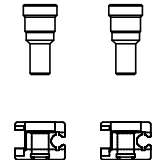
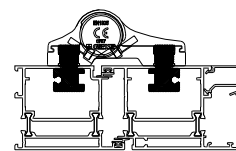

AKSESUARLAR ACCESSOIRES

PENCERE VE KAPI AÇILIM MEKANİZMALARI WINDOW AND DOOR OPENING MECHANISMS

İki ve üç yapraklı kapı menteşesi için bağlantı
Two and three-leaf hinges door for counterplates

D-896 (ithal) D-896-a (yerli) naturel eloksalı
(import) (native) (mat anodized)

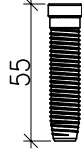
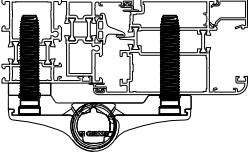

İki ve üç yapraklı kapı menteşesi için bağlantı
Two and three-leaf hinges door for counterplates

D-897 (ithal) D-897-a (yerli) naturel eloksalı
(import) (native) (mat anodized)

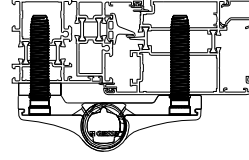

İki yapraklı kapı menteşesi (XL)
Two-leaf hinges for door (XL)

D-812 (ithal) D-812-a (yerli) naturel eloksalı
(import) (native) (mat anodized)
D-813 (ithal) D-813-a (yerli) pres veya renkli
(import) (native) (mill finish and painted)

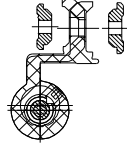

max.100 kg

Üç yapraklı kapı menteşesi (XXL)
Three-leaf hinges for door (XXL)

D-815 (ithal) D-815-a (yerli) naturel eloksalı
(import) (native) (mat anodized)
D-816 (ithal) D-816-a (yerli) pres veya renkli
(import) (native) (mill finish and painted)

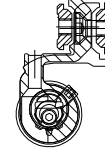

max.160 kg

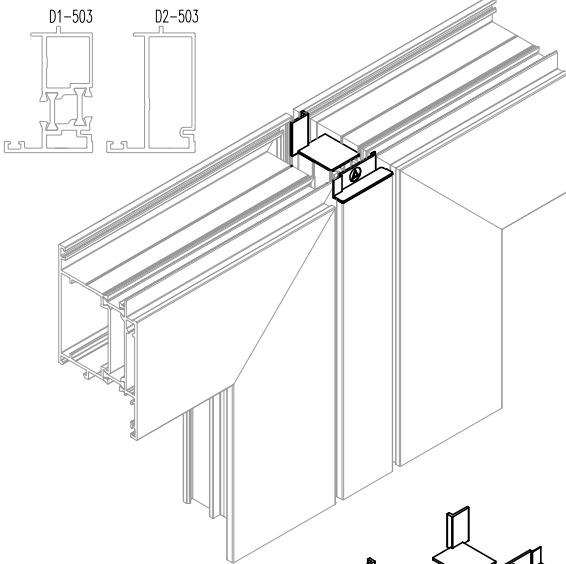

Pvc adaptör kapak (takım)
Pvc adapter cover (set)

D-900 (yerli)
(native)

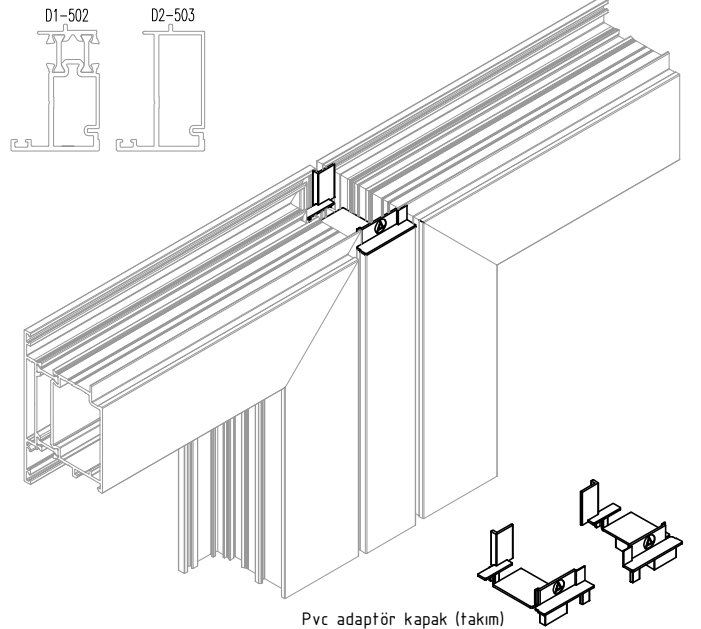

Pvc adaptör kapak (takım)
Pvc adapter cover (set)

D-900-a (yerli)
(native)

AKSESUARLAR ACCESSOIRES

PENCERE VE KAPI AÇILIM MEKANİZMALARI WINDOW AND DOOR OPENING MECHANISMS

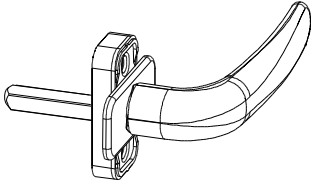

Prima kapı kolu
Prima handle

- D-821 (ithal) D-821-a (yerli) naturel eloksalli
(import) (native) (mat anodized)
- D-822 (ithal) D-822-a (yerli) pres veya renkli
(import) (native) (mill finishand and painted)

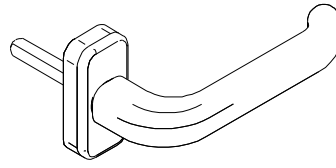

Prima kapı kolu (sağ-sol)
Prima handle (LH/RH)

- D-824 (ithal) D-824-a (yerli) naturel eloksalli
(import) (native) (mat anodized)
- D-825 (ithal) D-825-a (yerli) pres veya renkli
(import) (native) (mill finishand and painted)



Prima ikili kapı kolu
Prima handle couple

- D-827 (ithal) D-827-a (yerli) naturel eloksalli
(import) (native) (mat anodized)
- D-828 (ithal) D-828-a (yerli) pres veya renkli
(import) (native) (mill finishand and painted)



Supermaster ikili kapı kolu
Supermaster handle-couple

- D-830 (ithal) D-830-a (yerli) naturel eloksalli
(import) (native) (mat anodized)
- D-831 (ithal) D-831-a (yerli) pres veya renkli
(import) (native) (mill finishand and painted)



Boru kol
Semi-circle handle

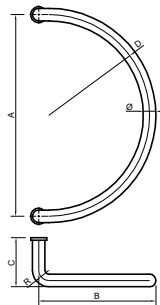

- D-833-X
naturel eloksalli
(mat anodized)
- D-834-X
pres veya renkli
(mill finishand and painted)

X	R	A	B	C	D	
1	20	25	110	110	60	55
2	20	25	150	130	60	75
3	20	25	200	140	60	100
4	25	40	200	150	80	100
5	25	40	300	210	80	150
6	25	40	400	250	80	200
7	30	55	300	250	80	150
8	30	55	350	250	80	175
9	32	55	300	250	80	150
10	32	55	350	175	80	175



Boru kol
Semi-circle curved handle

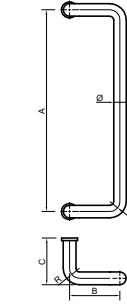

- D-836-X
naturel eloksalli
(mat anodized)
- D-837-X
pres veya renkli
(mill finishand and painted)

X	R	A	B	C	
1	20	25	110	90	60
2	20	25	150	90	60
3	20	25	200	90	60
4	25	40	200	100	80
5	25	40	250	100	80
6	25	40	300	100	80
7	25	40	350	100	80
8	25	40	400	100	80
9	30	40	300	100	80
10	30	50	350	130	80
11	30	50	600	130	80
12	32	50	300	150	80
13	32	50	350	150	80



Boru kol
Spring handle

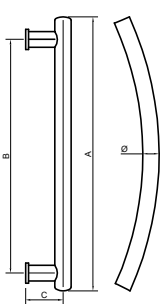

- D-839-X
naturel eloksalli
(mat anodized)
- D-840-X
pres veya renkli
(mill finishand and painted)

X	R	A	B	C	
1	30	750	600	1500	75
2	30	750	750	1600	75

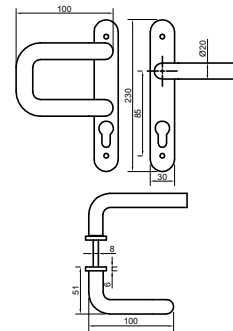

Düz-kıvrık aynalı kol
Flat-curve mirrored handles

- D-842-X
naturel eloksalli
(mat anodized)
- D-843-X
pres veya renkli
(mill finishand and painted)



Lama bant kol
Lama stripe handle

- D-845-X
naturel eloksalli
(mat anodized)

- D-846-X
pres veya renkli
(mill finishand and painted)

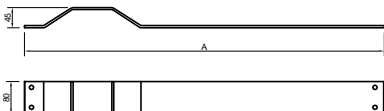

X	A
1	900
2	1000

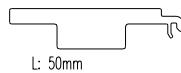

L: 50mm

Cam altı takozu (yerli)
Glass support piece (native)

- D-869 W1-W2-W3-W4-D1-D2
D65-869 W5-W6-S3
D75-869 W7-W8
D45-869 W9-W10

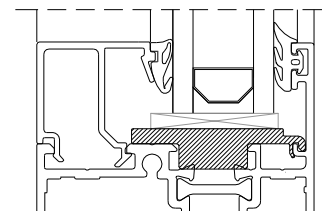

AKSESUARLAR ACCESSOIRES

PENCERE VE KAPI AÇILIM MEKANİZMALARI WINDOW AND DOOR OPENING MECHANISMS

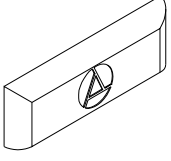

Pvc su tahliye parçası
Drainage hole cover

D-870 (yerli)
(native)

(renk seçeneği belirtilmelidir)
(colour choice must be stated)



Köşe birleştirme aparatı
Shoulder aligning square

D-872 (yerli)
(native)

alüminyum 1.5mm

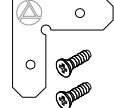

Köşe birleştirme aparatı
Shoulder aligning square

D-872-1 (yerli)
(native)

alüminyum 1.5mm



Kapı altı fırçası
Door brush

D-873 (yerli)
(native)



Dıştan uygulama kapı sürgüsü
Door lever bolt (from outside application)

D-882 (ithal) D-882-a (yerli) naturel eloksalli
(import) (native) (mat anodized)

D-883 (ithal) D-883-a (yerli) pres veya renkli
(import) (native) (mill finish and painted)



Kapı sürgüsü
Door lever bolt

D-901 (ithal) D-901-a (yerli) naturel eloksalli
(import) (native) (mat anodized)

D-902 (ithal) D-902-a (yerli) pres veya renkli
(import) (native) (mill finish and painted)



Giesse panik kol
Panic bar mechanism

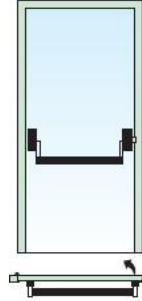

D-857
naturel eloksalli
(mat anodized)

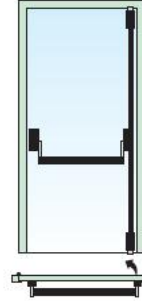

D-860
naturel eloksalli
(mat anodized)

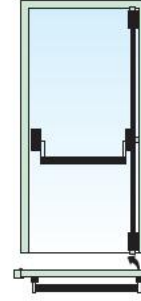

D-863
naturel eloksalli
(mat anodized)

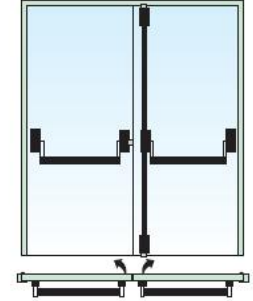

D-866
naturel eloksalli
(mat anodized)

D-858
pres veya renkli
(mill finish and painted)

D-861
pres veya renkli
(mill finish and painted)

D-864
pres veya renkli
(mill finish and painted)

D-867
pres veya renkli
(mill finish and painted)

AKSESUARLAR ACCESSOIRES

PENCERE VE KAPI AÇILIM MEKANİZMALARI WINDOW AND DOOR OPENING MECHANISMS

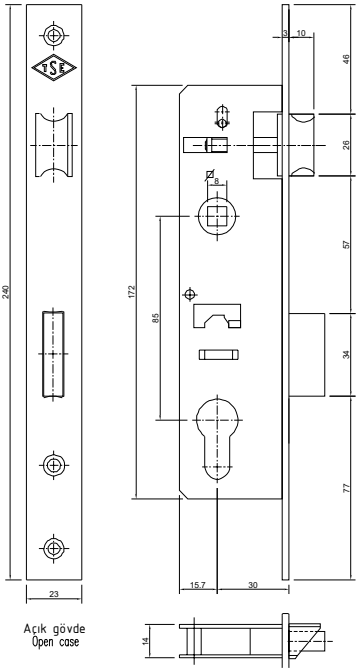

153U-30
Dar kilit(dilli)
Narrow lock (bolt)
D-874 (yerli) metalik
(native) metallic

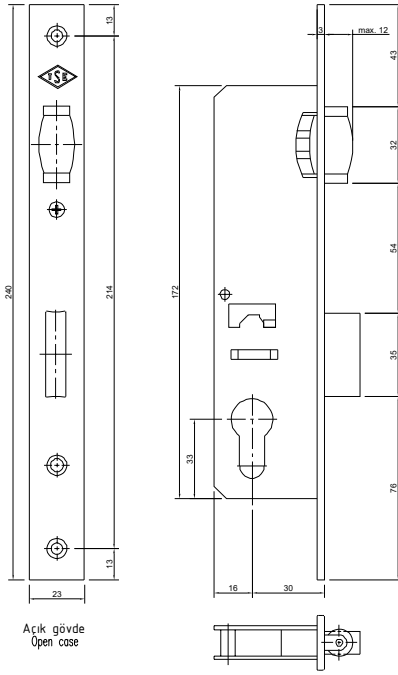

155U-30
Dar kilit (makaralı)
Narrow lock (roller)
D-876 (yerli) metalik
(native) metallic

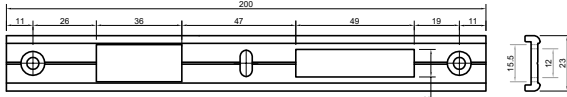

D-851 (yerli) naturel eloksalli
(native) (mat anodized)

D-852 (yerli) pres veya renkli
(native) (mill finishand and painted)

Kilit karşılığı
Lock plate

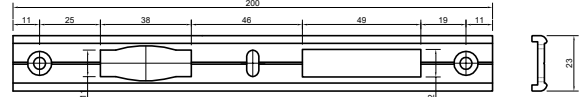

D-854 (yerli) naturel eloksalli
(native) (mat anodized)

D-855 (yerli) pres veya renkli
(native) (mill finishand and painted)

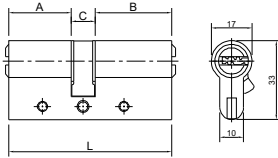

A	C	B	L	Barel Cylinders
26	10	26	62	D-878-1 (yerli) metalik
26	10	32	68	D-878-2 (yerli) metalik
30	10	40	80	D-878-3 (yerli) metalik
30	10	45	85	D-878-4 (yerli) metalik
30	10	50	90	D-878-5 (yerli) metalik
30	10	60	100	D-878-6 (yerli) metalik
25	10	65	100	D-878-7 (yerli) metalik
25	10	70	105	D-878-8 (yerli) metalik

Barel rozeti
Cylinder cover



D-848-1 naturel eloksalli (mat anodized)

D-848-2 pres veya renkli (mill finishand and painted)



D-849-1 naturel eloksalli (mat anodized)

D-849-2 pres veya renkli (mill finishand and painted)



D-850-1 naturel eloksalli (mat anodized)

D-850-2 pres veya renkli (mill finishand and painted)

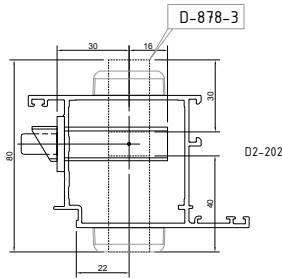

D-878-3

D2-202

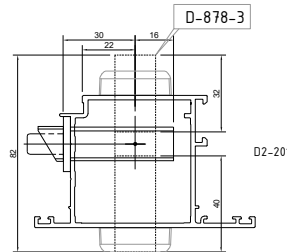

D-878-3

D2-201

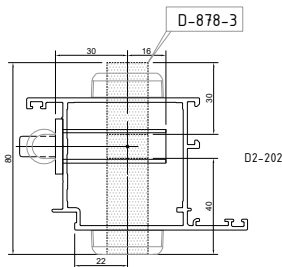

D-878-3

D2-202

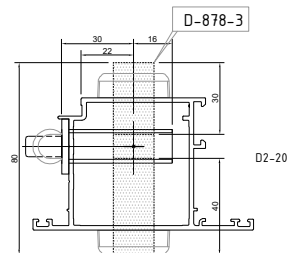

D-878-3

D2-201