

Yalıtımsız Pencere ve Kapı Serisi Açılım Varyasyonları

Noninsulated Window and Door Serie Opening Variations

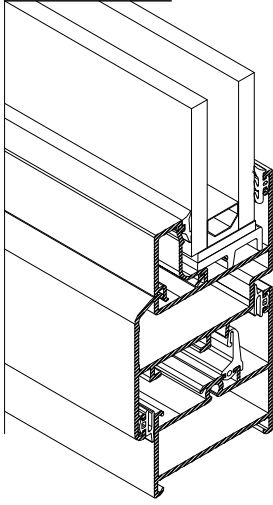

PENCERE SERİ
WINDOW SERIE

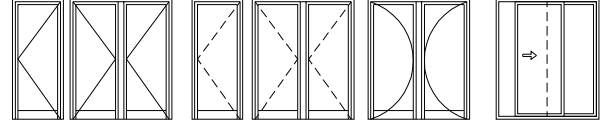
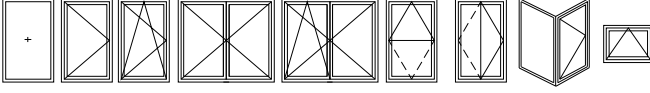
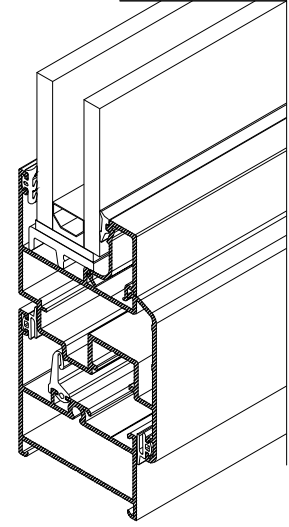

PENCERE SERİ
(PVC AKSESUAR)
WINDOW SERIE
(PVC ACCESSORIES)

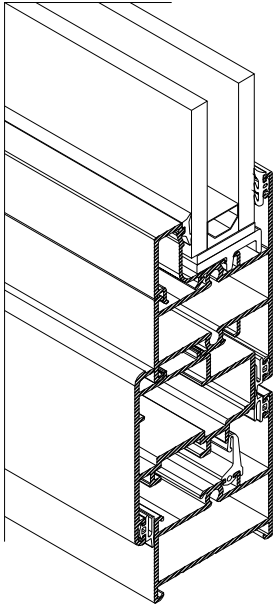

PİVOT SERİ
PIVOT SERIE

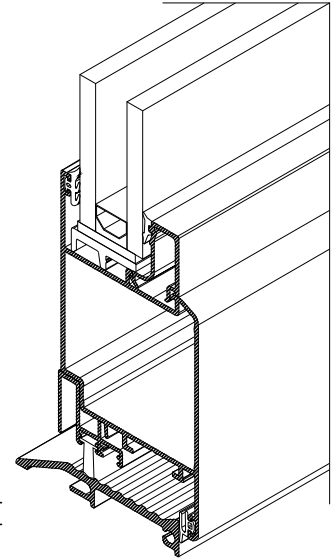

KAPI SERİ
DOOR SERIE

W10

W 45 - 1.4 Yalıtımsız Pencere ve Kapı Serisi
W45-1.4 Noninsulated Window and Door Serie

Alaşım Özellikleri Alloy Properties











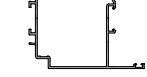

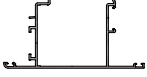
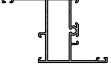
EN AW 6060 (AlMgSi0,5 F22) EN AW 6063(AlMg0,7Si F22)

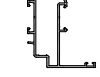
Üretim ve Mekanik Standartları Production and Mechanical Standards

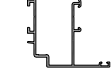
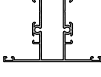
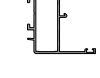
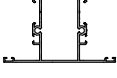
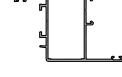
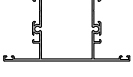
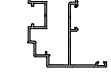
EN 12020-2 - EN 755-9 - EN 755-2

W10

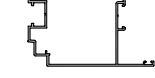
ÜRÜN TEKNİK ÖZELLİKLERİ PRODUCT'S TECHNICAL FEATURES





















PROFİL KESİTİ PROFILE VIEW	PROFİL NO PROFILE NO	PROFİL AÇIKLAMASI PROFILE DESCRIPTION	gr/m	PROFİL KESİTİ PROFILE VIEW	PROFİL NO PROFILE NO	PROFİL AÇIKLAMASI PROFILE DESCRIPTION	gr/m
	W10-101 (48 - 28)	KASA PROFİLİ FRAME	704		W10-208 (67 - 78)	İÇE AÇILIR KAPI KANADI INDOOR CASEMENT PROFILE FOR DOOR	1095
	W10-102 (58 - 38)	KASA PROFİLİ FRAME	779		W10-209 (98 - 53)	DIŞA AÇILIR KAPI KANADI OUTDOOR CASEMENT PR. FOR DOOR	1095
 ⚠ İşaretti profil için satış temsilcinizden bilgi alınır.	W10-105 (48 - 53)	PERVAZLI KASA PROFİLİ FRAME	824	 ⚠ İşaretti profil için satış temsilcinizden bilgi alınır.	W10-212 (81 - 92)	İÇE AÇILIR KAPI KANADI INDOOR CASEMENT PROFILE FOR DOOR	1201
	W10-201 (34 - 45)	PENCERE KANAT PROFİLİ CASEMENT PROFILE FOR WINDOW	835	 ⚠ İşaretti profil için satış temsilcinizden bilgi alınır.	W10-213 (112 - 61)	İÇE AÇILIR KAPI KANADI INDOOR CASEMENT PROFILE FOR DOOR	1201
 ⚠ İşaretti profil için satış temsilcinizden bilgi alınır.	W10-202 (44 - 55)	PENCERE KANAT PROFİLİ CASEMENT PROFILE FOR WINDOW	920		W10-301 (68 - 28)	ORTA KAYIT PROFİLİ TRANSOM PROFILE	861
 ⚠ İşaretti profil için satış temsilcinizden bilgi alınır.	W10-204 (45 - 43)	PENCERE KANAT PROFİLİ CASEMENT PROFILE FOR WINDOW	786		W10-302 (78 - 38)	ORTA KAYIT PROFİLİ TRANSOM PROFILE	936
 ⚠ İşaretti profil için satış temsilcinizden bilgi alınır.	W10-214 (55 - 53)	PENCERE KANAT PROFİLİ CASEMENT PROFILE FOR WINDOW	862	 ⚠ İşaretti profil için satış temsilcinizden bilgi alınır.	W10-303 (88 - 48)	ORTA KAYIT PROFİLİ TRANSOM PROFILE	1012
	W10-205 (41.4 - 52.4)	PENCERE KANAT PROFİLİ CASEMENT PROFILE FOR WINDOW	959		W10-304 (78 - 106.3)	TAKVİYELİ ORTA KAYIT REINFORCED TRANSOM PROFILE	1690
 ⚠ İşaretti profil için satış temsilcinizden bilgi alınır.	W10-206 (51.4 - 62.4)	PENCERE KANAT PROFİLİ CASEMENT PROFILE FOR WINDOW	1035	 ⚠ İşaretti profil için satış temsilcinizden bilgi alınır.	W10-401 (110 - 70)	ETEK-ORTA KAYIT PROFİLİ PLINTH-TRANSOM PROFILE	1180
	W10-207 (105.4 - 52.5)	İÇE AÇILIR KAPI KANADI INDOOR CASEMENT PROFILE FOR DOOR	1210		W10-403 (139 - 119)	ETEK PROFİLİ PLINTH PROFILE	1447

Profil değerleri teoriktir. Ağırlık olarak testimde yapılan tartım geçerlidir.
Profil imatları TS EN 12020-2 ve TS EN 755-9 toleransı,
Moment değerleri EN 14024'e göre hesaplanmıştır.

Profile values are theoretical pre-shipment weight will be valid.
The tolerances of Profile manufacturing are calculated according to EN 12020-2
and TS EN 755-9; moment values are calculated according to EN 14024.

W10

ÜRÜN TEKNİK ÖZELLİKLERİ PRODUCT'S TECHNICAL FEATURES

PROFİL KESİTİ PROFILE VIEW	PROFİL NO PROFILE NO	PROFİL AÇIKLAMASI PROFILE DESCRIPTION	gr/m	PROFİL KESİTİ PROFILE VIEW	PROFİL NO PROFILE NO	PROFİL AÇIKLAMASI PROFILE DESCRIPTION	gr/m
 ⚠ İşaretti profil için satış temsilcinizden bilgi alınır.	W10-402 (170 - 150)	ETEK PROFİLİ PLINTH PROFILE	1683		W10-550 (47.1 - 47.1)	90 KÖŞE PROFİLİ 90 CORNER PROFILE	736
	W10-501 (57 - 58.4)	AÇILIM ADAPTÖRÜ OPENING ADAPTER	795		W10-609 (39.2 - 41.8)	ORTA KAYIT BİRLEŞTİRME CORNER CLEATS FOR TRANSOM	902
	W10-501-a (57 - 48.4)	AÇILIM ADAPTÖRÜ OPENING ADAPTER	799		W10-620 (45 - 16.5)	KÖŞE DÖNÜŞ ADAPT. CORNER PROFILE	292
 ⚠ İşaretti profil için satış temsilcinizden bilgi alınır.	W10-503 (45.9 - 57)	PİVOT ADAPT. PROFİLİ PIVOT ADAPT. PROFILE	859		W10-621 (30 - 14.6)	ORTA KAYIT BİRLEŞTİRME CORNER CLEATS FOR TRANSOM	423
 ⚠ İşaretti profil için satış temsilcinizden bilgi alınır.	W10-504 (18.8 - 45.1)	ÇARPMA KAPI ADAPTÖRÜ IMPACT DOOR ADAPTER	285	 ⚠ İşaretti profil için satış temsilcinizden bilgi alınır.	W10-622 (30 - 24.6)	ORTA KAYIT BİRLEŞTİRME CORNER CLEATS FOR TRANSOM	508
	W10-505 (12.4 - 45)	ÇARPMA KAPI ADAPTÖRÜ IMPACT DOOR ADAPTER	239	 ⚠ İşaretti profil için satış temsilcinizden bilgi alınır.	W10-623 (30 - 34.6)	ORTA KAYIT BİRLEŞTİRME CORNER CLEATS FOR TRANSOM	590
 ⚠ İşaretti profil için satış temsilcinizden bilgi alınır.	W-506 (31.9 - 29)	PANJUR PROFİLİ SHUTTER PROFILE	363	 ⚠ İşaretti profil için satış temsilcinizden bilgi alınır.	W10-630 (R:40)	KÖŞE PROFİLİ CORNER PROFILE	647
 ⚠ İşaretti profil için satış temsilcinizden bilgi alınır.	W-507 (44 - 55)	PANJUR DÜŞEY PROFİLİ SHUTTER VERTICAL PROFILE	834		W-503 (29.3 - 20.1)	DAMLALIK PROFİLİ WEATHERDIP PROFILE	211
	W10-508 (29.3 - 31)	ETEK ADAPTÖRÜ PLINTH ADAPTER	300		W4-504 (17.3 - 25)	ETEK ADAPTÖRÜ PLINTH ADAPTER	227
	W10-510 (49.5 - 45)	AÇILIM ADAPTÖRÜ OPENING ADAPTER	686		W4-505 (12.8 - 25)	ETEK ADAPTÖRÜ PLINTH ADAPTER	184

Profil değerleri teoriktir. Ağırlık olarak testimde yapılan tartım geçerlidir.
Profil imalatları TS EN 12020-2 ve TS EN 755-9 toleransı,
Moment değerleri EN 14024'e göre hesaplanmıştır.

Profile values are theoretical pre-shipment weight will be valid.
The tolerances of Profile manufacturing are calculated according to EN 12020-2
and TS EN 755-9; moment values are calculated according to EN 14024.

W10

ÜRÜN TEKNİK ÖZELLİKLERİ PRODUCT'S TECHNICAL FEATURES

PROFİL KESİTİ PROFILE VIEW	PROFİL NO PROFILE NO	PROFİL AÇIKLAMASI PROFILE DESCRIPTION	gr/m	PROFİL KESİTİ PROFILE VIEW	PROFİL NO PROFILE NO	PROFİL AÇIKLAMASI PROFILE DESCRIPTION	gr/m
	W-511 (3.5 - 24.5)	CAM ÇITASI GLASS BEAM	187	  İşaretti profil için satış temsilcinizden bilgi alınız.	W-511-a (3.5 - 24.4)	CAM ÇITASI GLASS BEAM	193
	W-512 (7.5 - 24.5)	CAM ÇITASI GLASS BEAM	206		W-512-a (7.5 - 24.5)	CAM ÇITASI GLASS BEAM	194
	W-513 (11.5 - 24.5)	CAM ÇITASI GLASS BEAM	227		W-513-a (11.5 - 24.4)	CAM ÇITASI GLASS BEAM	216
	W-514 (15.5 - 24.5)	CAM ÇITASI GLASS BEAM	252		W-514-a (15.5 - 24.4)	CAM ÇITASI GLASS BEAM	228
	W-515 (19.5 - 24.5)	CAM ÇITASI GLASS BEAM	273		W-515-a (19.5 - 24.4)	CAM ÇITASI GLASS BEAM	242
	W-516 (23.5 - 24.5)	CAM ÇITASI GLASS BEAM	286		W-516-a (23.5 - 24.4)	CAM ÇITASI GLASS BEAM	270
	W-517 (27.5 - 24.5)	CAM ÇITASI GLASS BEAM	299		W-517-a (27.5 - 24.4)	CAM ÇITASI GLASS BEAM	284
					W-518-a (31.5 - 24.4)	CAM ÇITASI GLASS BEAM	297
					W-512-B (7.5 - 24.2)	CAM ÇITASI GLASS BEAM	227

Profil değerleri teoriktir. Ağırlık olarak testimde yapılan tartım geçerlidir.
Profil imalatları TS EN 12020-2 ve TS EN 755-9 toleransı,
Moment değerleri EN 14024'e göre hesaplanmıştır.

Profile values are theoretical pre-shipment weight will be valid.
The tolerances of Profile manufacturing are calculated according to EN 12020-2
and TS EN 755-9; moment values are calculated according to EN 14024.

W10

ÜRÜN TEKNİK ÖZELLİKLERİ PRODUCT'S TECHNICAL FEATURES

PROFİL KESİTİ PROFILE VIEW	PROFİL NO PROFILE NO	PROFİL AÇIKLAMASI PROFILE DESCRIPTION	gr/m	PROFİL KESİTİ PROFILE VIEW	PROFİL NO PROFILE NO	PROFİL AÇIKLAMASI PROFILE DESCRIPTION	gr/m
	W-521 (124 - 10)	LAMBİRİ PROFİLİ WAINSCOT PROFILE	805		W-531 (170 - 2)	DENİZLİK PROFİLİ CULVERT PROFILE	1322
	W-522 (88 - 10)	LAMBİRİ PROFİLİ WAINSCOT PROFILE	519		W-532 (190 - 2.2)	DENİZLİK PROFİLİ CULVERT PROFILE	1573
	W-523 (45 - 75.8)	MENFEZ PROFİLİ CULVERT PROFILE	647		W-533 (210 - 2.2)	DENİZLİK PROFİLİ CULVERT PROFILE	1696
	W-524 (105 - 1.6)	DENİZLİK PROFİLİ CULVERT PROFILE	639		W-534 (40 - 26.5)	BİNİ PROFİLİ INTERLOCKING PROFILE	328
	W-525 (105 - 1.8)	DENİZLİK PROFİLİ CULVERT PROFILE	714		W-535 (40 - 26.5)	BİNİ PROFİLİ INTERLOCKING PROFILE	229
	W-526 (160.61 - 1.8)	DENİZLİK PROFİLİ CULVERT PROFILE	1066		W-536 (40 - 26)	BİNİ PROFİLİ INTERLOCKING PROFILE	292
	W-527 (160.61 - 2)	DENİZLİK PROFİLİ CULVERT PROFILE	1181		W-537 (25 - 26)	BİNİ PROFİLİ INTERLOCKING PROFILE	226
	W-528 (206.58 - 1.9)	DENİZLİK PROFİLİ CULVERT PROFILE	1367		W-538 (25 - 25)	BİNİ PROFİLİ INTERLOCKING PROFILE	249
	W-529 (206.58 - 2.2)	DENİZLİK PROFİLİ CULVERT PROFILE	1577		W-539 (45 - 35)	BİNİ PROFİLİ INTERLOCKING PROFILE	460
	W-530 (150 - 2)	DENİZLİK PROFİLİ CULVERT PROFILE	1209		W-540 (20.6 - 40.4)	BİNİ PROFİLİ INTERLOCKING PROFILE	208

Profil değerleri teoriktir. Ağırlık olarak testimde yapılan tartım geçerlidir.
Profil imalatları TS EN 12020-2 ve TS EN 755-9 toleransı,
Moment değerleri EN 14024'e göre hesaplanmıştır.

Profile values are theoretical pre-shipment weight will be valid.
The tolerances of Profile manufacturing are calculated according to EN 12020-2
and TS EN 755-9; moment values are calculated according to EN 14024.

W10

ÜRÜN TEKNİK ÖZELLİKLERİ PRODUCT'S TECHNICAL FEATURES





PROFİL KESİTİ PROFILE VIEW	PROFİL NO PROFILE NO	PROFİL AÇIKLAMASI PROFILE DESCRIPTION	gr/m	PROFİL KESİTİ PROFILE VIEW	PROFİL NO PROFILE NO	PROFİL AÇIKLAMASI PROFILE DESCRIPTION	gr/m
	W1-508 (4.2 - 19)	TIJ PROFİLİ PUSHING ROD PROFILE	138		W-558 (37.6 - 20)	ETEK ADAPTÖRÜ PLINTH ADAPTER	173
	W-509 (95 - 4)	LAMBİRİ PROFİLİ WAINSCOT PROFILE	319		W-559 (37.6 - 20)	ETEK ADAPTÖRÜ PLINTH ADAPTER	216
	W-510 (4.3 - 92.7)	LAMBİRİ PROFİLİ WAINSCOT PROFILE	342		W3-511 (16 - 57.4)	CEPHE BAĞLANTI PROFİLİ CONNECTION PROFILE FOR FAÇADE	496
	W-541 (28 - 26.7)	BİNİ PROFİLİ INTERLOCKING PROFILE	219		W-625 (74 - 74) 14.6mm	KÖŞE BİRLEŞTİRME CORNER CLEATS	1560
	W-542 (48.5 - 26.3)	BİNİ PROFİLİ INTERLOCKING PROFILE	306		W-611 (70 - 70) 14.6mm	KÖŞE BİRLEŞTİRME CORNER CLEATS	2520
	W-543 (20 - 22)	KASA ADAPTÖRÜ FRAME ADAPTER	213		W-626 (65.3 - 65.3) 24.6mm	KÖŞE BİRLEŞTİRME CORNER CLEATS	1762
	W-544 (88 - 10)	EŞİK PROFİLİ THRESHOLD PROFILE	728		W-612 (67 - 67) 24.6mm	KÖŞE BİRLEŞTİRME CORNER CLEATS	3524
	W-545 (62.3 - 12)	EŞİK PROFİLİ THRESHOLD PROFILE	578		W-627 (72.6 - 72.6) 34.6mm	KÖŞE BİRLEŞTİRME CORNER CLEATS	2091
	W-555 (17 - 47.5)	EŞİK PROFİLİ THRESHOLD PROFILE	PVC 767 POLYAMİD 758		W-613 (85 - 85) 34.6mm	KÖŞE BİRLEŞTİRME CORNER CLEATS	3945
	W-557 (24.5 - 20.5)	ETEK ADAPTÖRÜ PLINTH ADAPTER	260		W-628 (82 - 82) 47.6mm	KÖŞE BİRLEŞTİRME CORNER CLEATS	2451

Profil değerleri teoriktir. Ağırlık olarak testimde yapılan tartım geçerlidir.
Profil imalatları TS EN 12020-2 ve TS EN 755-9 toleransı,
Moment değerleri EN 14024'e göre hesaplanmıştır.

Profile values are theoretical pre-shipment weight will be valid.
The tolerances of Profile manufacturing are calculated according to EN 12020-2
and TS EN 755-9; moment values are calculated according to EN 14024.

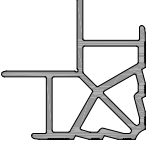
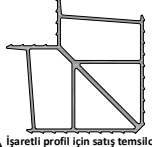
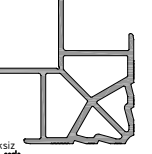
W10

ÜRÜN TEKNİK ÖZELLİKLERİ PRODUCT'S TECHNICAL FEATURES

PROFİL KESİTİ PROFILE VIEW	PROFİL NO PROFILE NO	PROFİL AÇIKLAMASI PROFILE DESCRIPTION	gr/m	PROFİL KESİTİ PROFILE VIEW	PROFİL NO PROFILE NO	PROFİL AÇIKLAMASI PROFILE DESCRIPTION	gr/m
	W-614 (100 - 100) 47.6mm	KÖŞE BİRLEŞTİRME CORNER CLEATS	5318				
 <small>⚠ İşaretili profil için satış temsilcilerinizden bilgi alınuz.</small>	W-629 (96.1 - 61.6) 61.6mm	KÖŞE BİRLEŞTİRME CORNER CLEATS	3090				
 <small>ölçeksiz not to scale</small>	W-615 (120,2 - 120,2) 61.6mm	KÖŞE BİRLEŞTİRME CORNER CLEATS	6313				
	SC0309 (55 - 55)	KÖŞE BİRLEŞTİRME CORNER CLEATS	1636				
	W4-508 (17.3 - 55)	PERVAZ ADAPTÖRÜ FRAME ADAPTER	356				
	W-548 (52.6 - 41.4)	BİNİ PROFİLİ INTERLOCKING PROFILE	424				

Profil değerleri teoriktir. Ağırlık olarak testimde yapılan tartım geçerlidir.
Profil imalatları TS EN 12020-2 ve TS EN 755-9 toleransı,
Moment değerleri EN 14024'e göre hesaplanmıştır.

Profile values are theoretical pre-shipment weight will be valid.
The tolerances of Profile manufacturing are calculated according to EN 12020-2
and TS EN 755-9; moment values are calculated according to EN 14024.

W10
W 45-1.4 YALITIMSIZ SERİ PROFİLLERİ
W45-1.4 NONINSULATED SERIES

ÜRÜN TEKNİK ÖZELLİKLERİ
PRODUCT'S TECHNICAL FEATURES

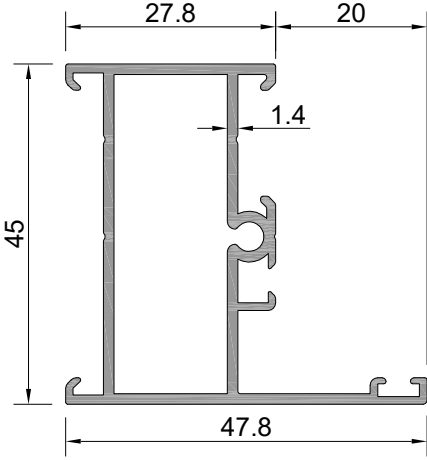

Profil No: W10-101
Ağırlık : 704 gr/m
lx : 7,03 cm⁴
ly : 3,36 cm⁴

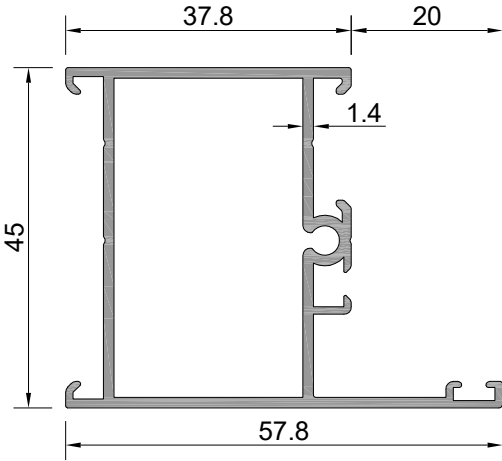
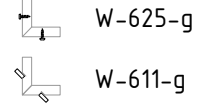

Profil No: W10-102
Ağırlık : 779 gr/m
lx : 8,38 cm⁴
ly : 6,52 cm⁴

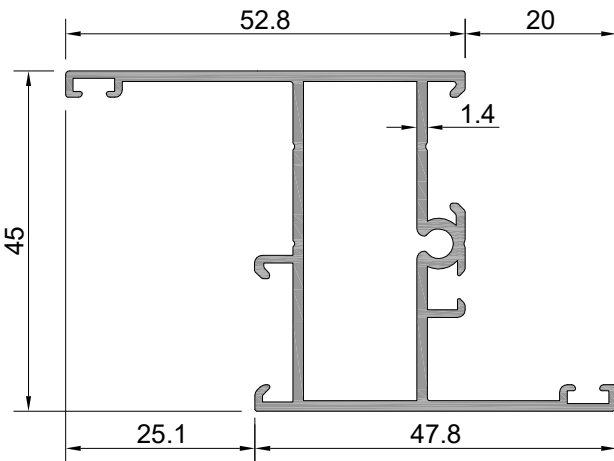
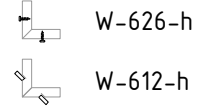

Profil No: W10-105 
Ağırlık : 824 gr/m
lx : 8,94 cm⁴
ly : 6,97 cm⁴

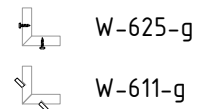

 İşaretili profil için satış temsilcinizden bilgi alın.

Profil değerleri teoriktir. Ağırlık olarak testimde yapılan tartım geçerlidir.
Profil imalatları TS EN 12020-2 ve TS EN 755-9 toleransı,
Moment değerleri EN 14024'e göre hesaplanmıştır.

Profile values are theoretical pre-shipment weight will be valid.
The tolerances of Profile manufacturing are calculated according to EN 12020-2
and TS EN 755-9; moment values are calculated according to EN 14024.

W10
W 45-1.4 YALITIMSIZ SERİ PROFİLLERİ
W45-1.4 NONINSULATED SERIES

ÜRÜN TEKNİK ÖZELLİKLERİ
PRODUCT'S TECHNICAL FEATURES

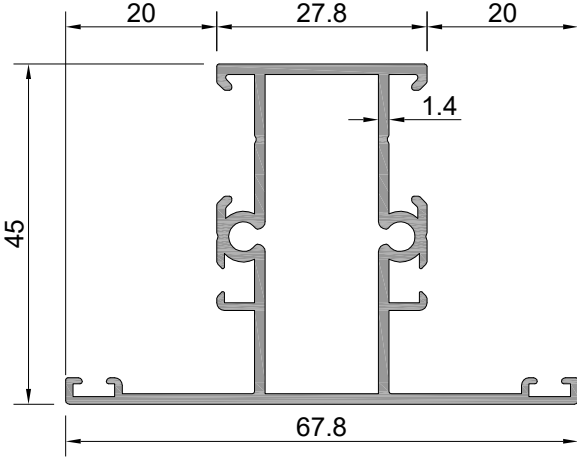

Profil No : W10-301
Ağırlık : 861 gr/m
lx : 8,15 cm⁴
ly : 6,23 cm⁴

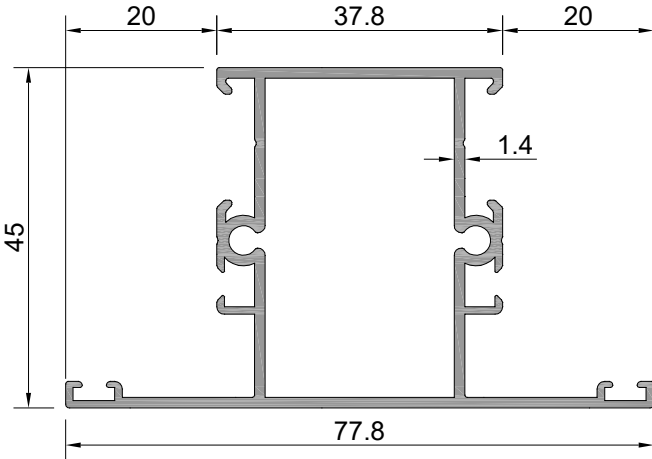
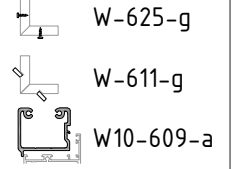

Profil No : W10-302
Ağırlık : 936 gr/m
lx : 9,53 cm⁴
ly : 10,83 cm⁴

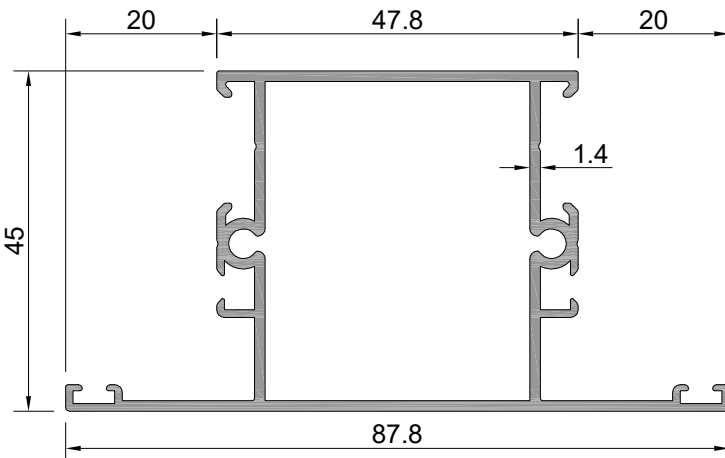
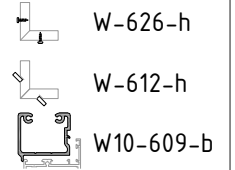

Profil No : W10-303 
Ağırlık : 1012 gr/m
lx : 10,90 cm⁴
ly : 17,16 cm⁴

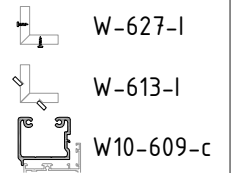

 İşareti profil için satış temsilcinizden bilgi alınız.

Profil değerleri teoriktir. Ağırlık olarak testimde yapılan tartım geçerlidir.
Profil imalatları TS EN 12020-2 ve TS EN 755-9 toleransı,
Moment değerleri EN 14024'e göre hesaplanmıştır.

Profile values are theoretical pre-shipment weight will be valid.
The tolerances of Profile manufacturing are calculated according to EN 12020-2
and TS EN 755-9; moment values are calculated according to EN 14024.

W10
W 45-1.4 YALITIMSIZ SERİ PROFİLLERİ
W45-1.4 NONINSULATED SERIES

ÜRÜN TEKNİK ÖZELLİKLERİ
PRODUCT'S TECHNICAL FEATURES

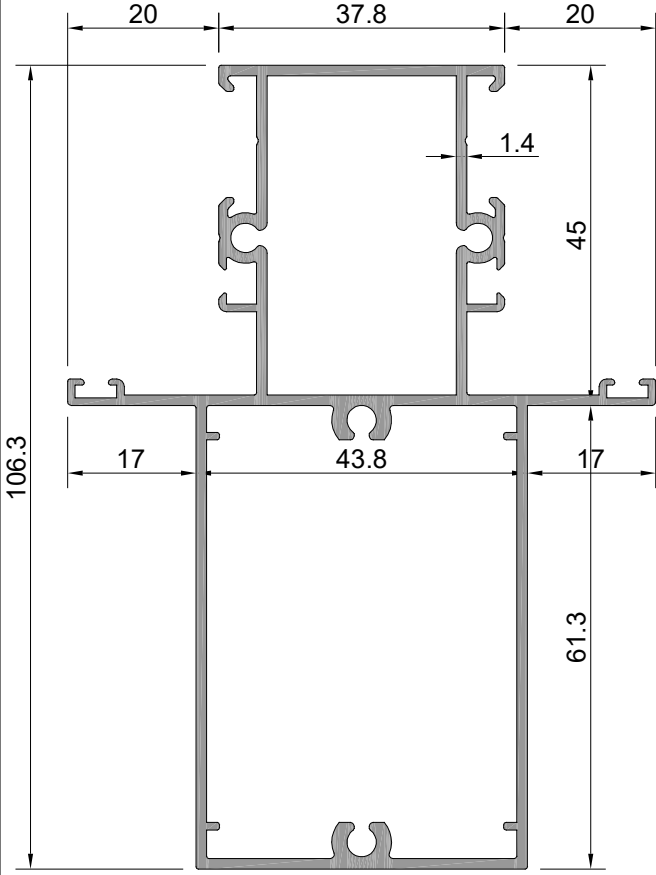

Profil No : W10-304

Ağırlık : 1690 gr/m

I_x : 70,04 cm⁴

I_y : 19,65 cm⁴

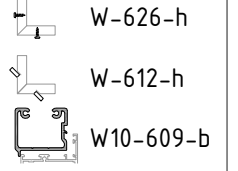

W10
W 45-1.4 YALITIMSIZ SERİ PROFİLLERİ
W45-1.4 NONINSULATED SERIES

ÜRÜN TEKNİK ÖZELLİKLERİ
PRODUCT'S TECHNICAL FEATURES

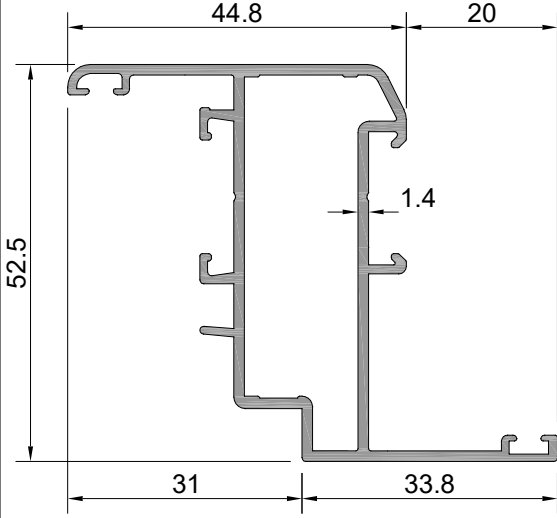

Profil No: W10-201

Ağırlık : 835 gr/m

I_x : 11,36 cm⁴

I_y : 5,51 cm⁴

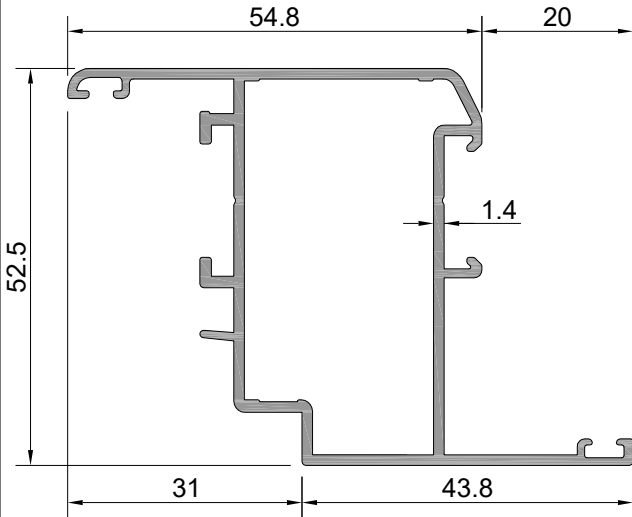
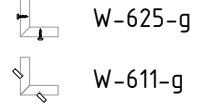



Profil No: W10-202 

Ağırlık : 920 gr/m

I_x : 13,26 cm⁴

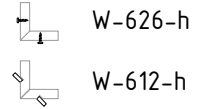
I_y : 9,89 cm⁴



 İşaretili profil için satış temsilcinizden bilgi alınız.

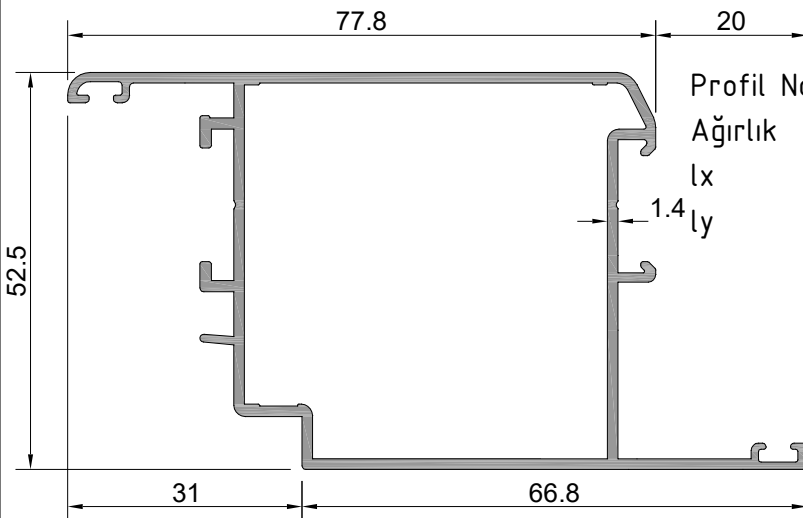

Profil No: W10-208

Ağırlık : 1095 gr/m

I_x : 17,47 cm⁴

I_y : 26,42 cm⁴

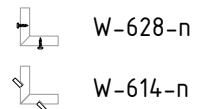

W10
W 45-1.4 YALITIMSIZ SERİ PROFİLLERİ
W45-1.4 NONINSULATED SERIES

ÜRÜN TEKNİK ÖZELLİKLERİ
PRODUCT'S TECHNICAL FEATURES

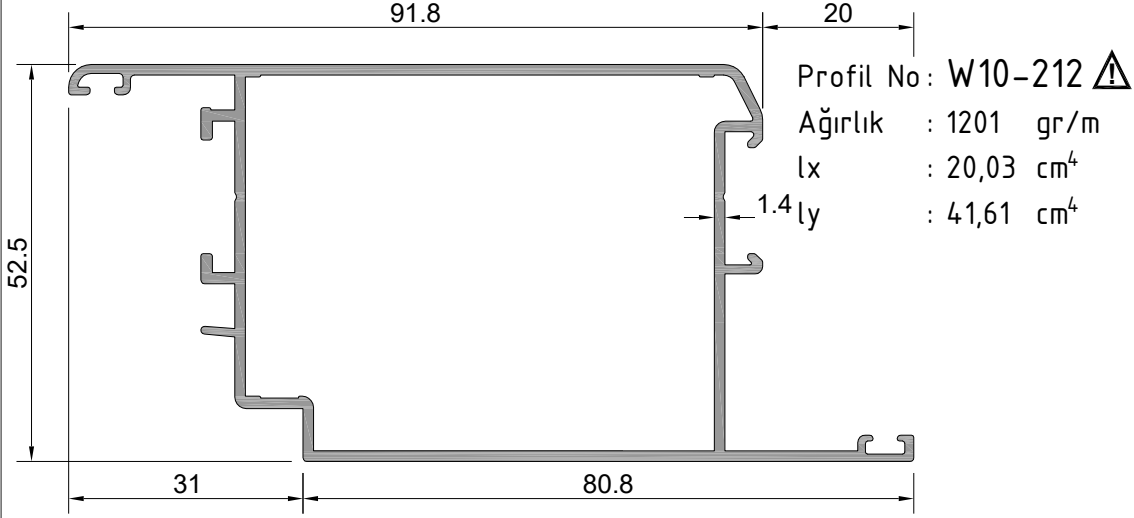

⚠ İşaretili profil için satış temsilcinizden bilgi alınır.

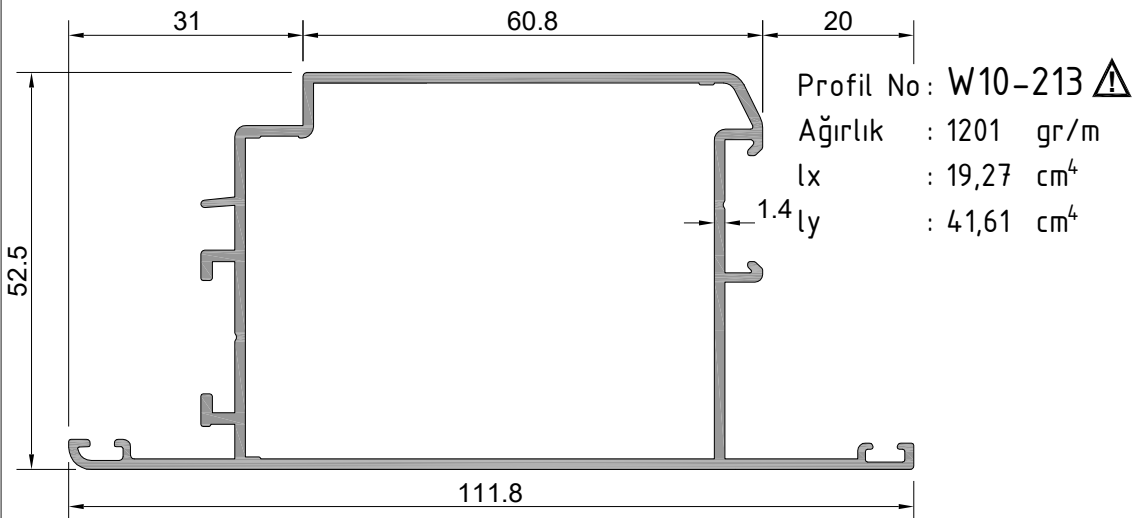
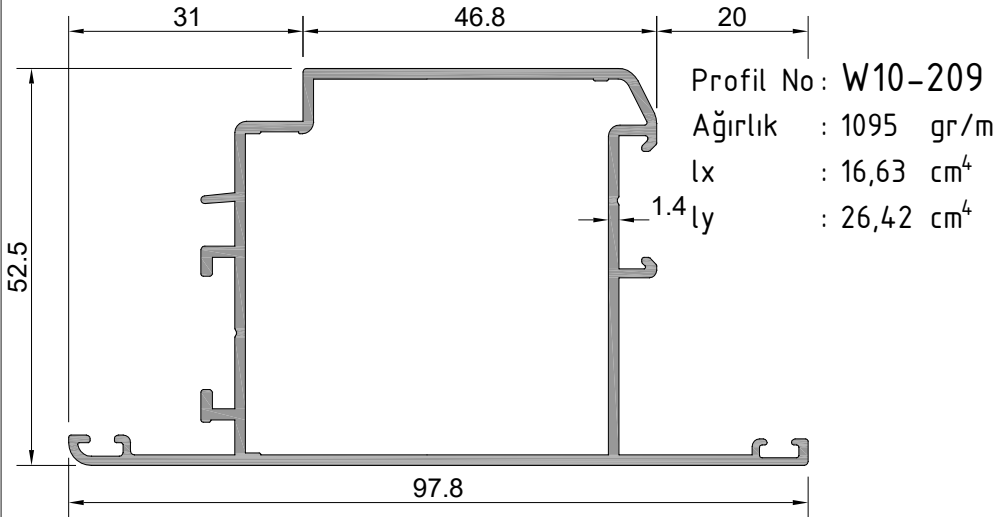

⚠ İşaretili profil için satış temsilcinizden bilgi alınır.

Profil değerleri teoriktir. Ağırlık olarak testimde yapılan tartım geçerlidir.
Profil imalatları TS EN 12020-2 ve TS EN 755-9 toleransı,
Moment değerleri EN 14024'e göre hesaplanmıştır.

Profile values are theoretical pre-shipment weight will be valid.
The tolerances of Profile manufacturing are calculated according to EN 12020-2
and TS EN 755-9; moment values are calculated according to EN 14024.

W10
W 45-1.4 YALITIMSIZ SERİ PROFİLLERİ
W45-1.4 NONINSULATED SERIES

ÜRÜN TEKNİK ÖZELLİKLERİ
PRODUCT'S TECHNICAL FEATURES

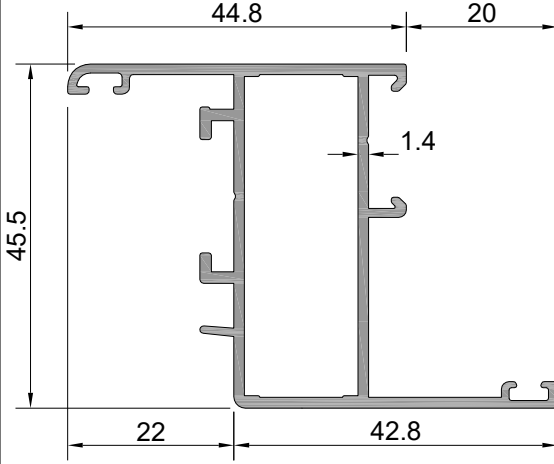

Profil No: W10-204 
Ağırlık : 786 gr/m
lx : 8,67 cm⁴
ly : 5,45 cm⁴

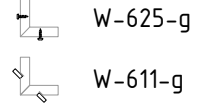

 İşaretti profil için satış temsilcinizden bilgi alınız.

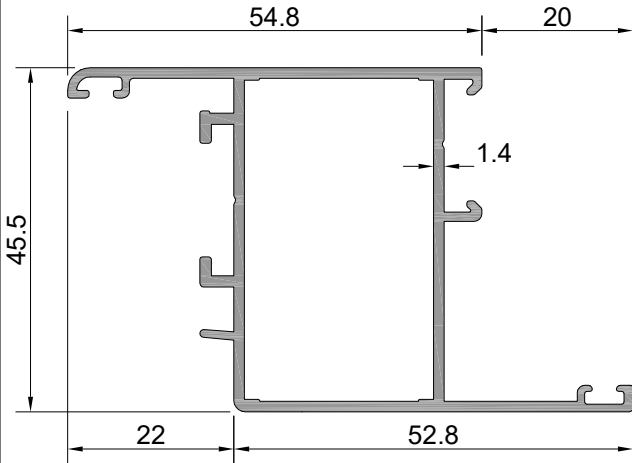

Profil No: W10-214 
Ağırlık : 862 gr/m
lx : 10,04 cm⁴
ly : 9,56 cm⁴

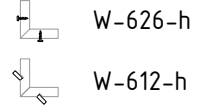

 İşaretti profil için satış temsilcinizden bilgi alınız.

W10
W 45-1.4 YALITIMSIZ SERİ PROFİLLERİ
W45-1.4 NONINSULATED SERIES

ÜRÜN TEKNİK ÖZELLİKLERİ
PRODUCT'S TECHNICAL FEATURES

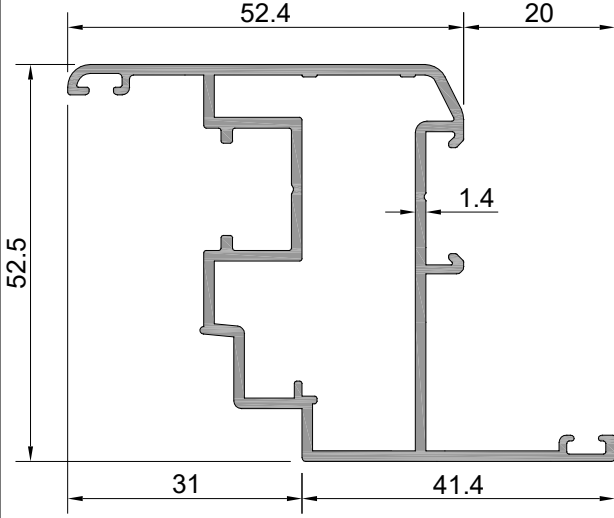

Profil No: W10-205

Ağırlık : 959 gr/m

I_x : 13,14 cm⁴

I_y : 8,65 cm⁴

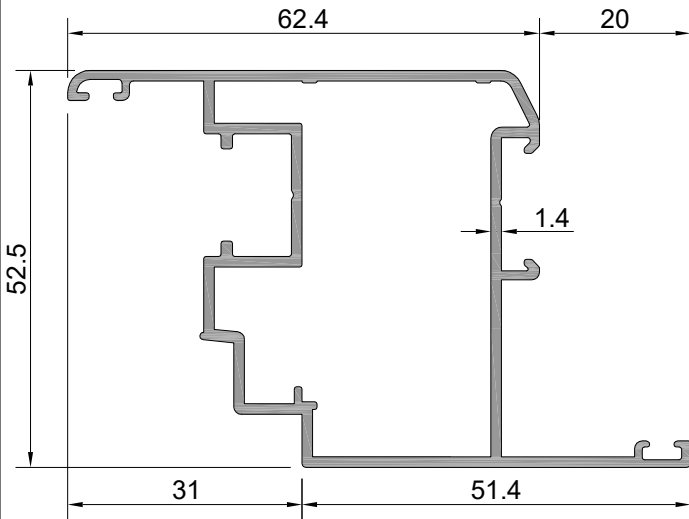
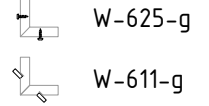

Profil No: W10-206 ⚠

Ağırlık : 1035 gr/m

I_x : 14,97 cm⁴

I_y : 14,27 cm⁴

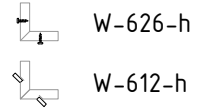

⚠ İşareti profil için satış temsilcinizden bilgi alınız.

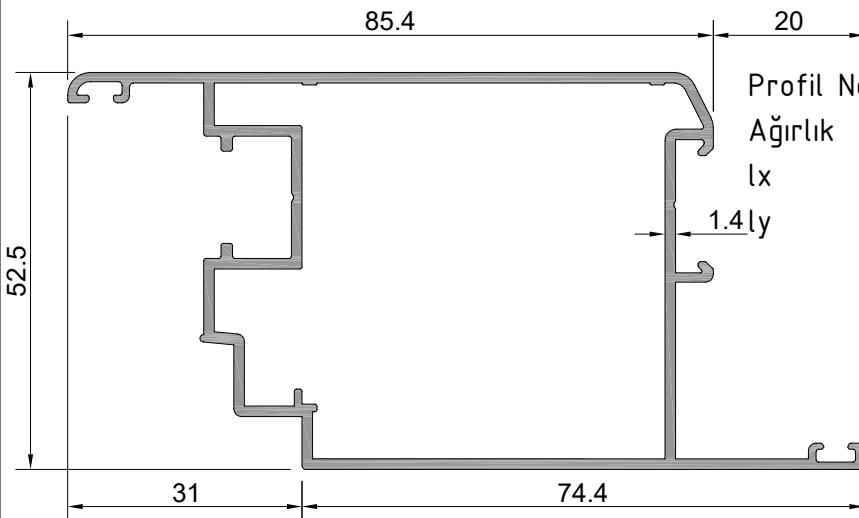

Profil No: W10-207

Ağırlık : 1210 gr/m

I_x : 19,19 cm⁴

I_y : 34,67 cm⁴

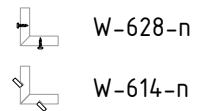

W10
W 45-1.4 YALITIMSIZ SERİ PROFİLLERİ
W45-1.4 NONINSULATED SERIES

ÜRÜN TEKNİK ÖZELLİKLERİ
PRODUCT'S TECHNICAL FEATURES

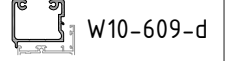
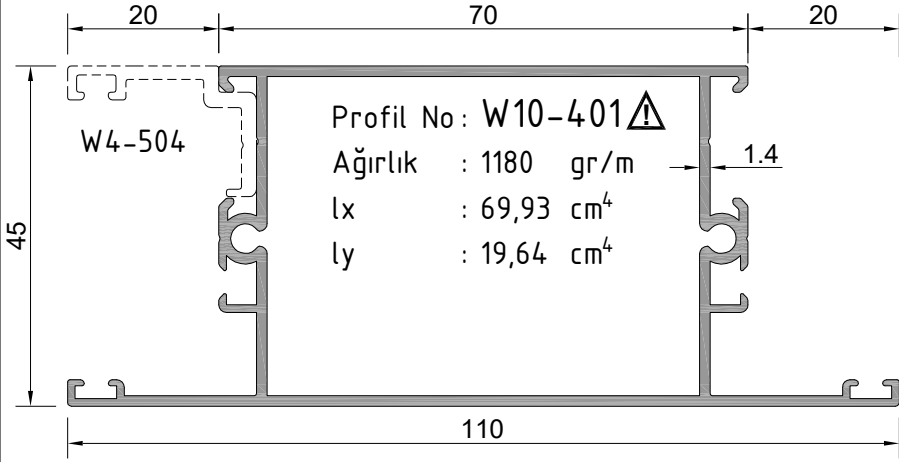

İşaretili profil için satış temsilcinizden bilgi alınız.

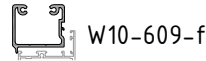
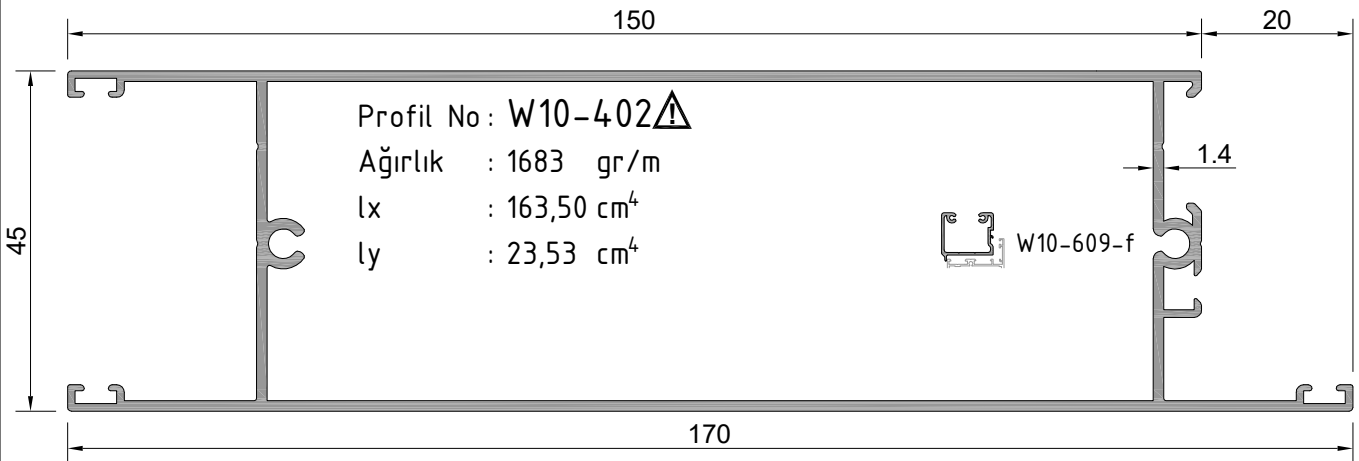
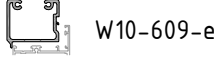
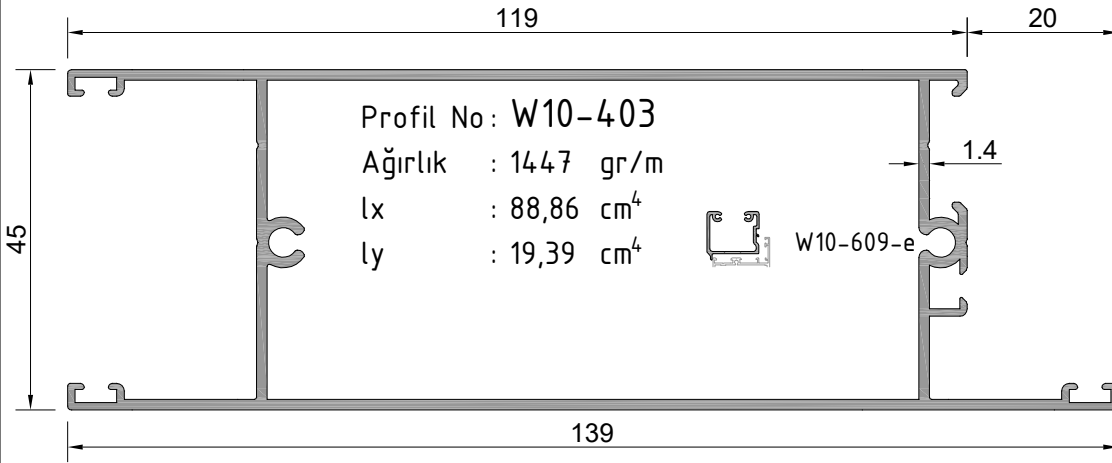

İşaretili profil için satış temsilcinizden bilgi alınız.

W10
W 45-1.4 YALITIMSIZ SERİ PROFİLLERİ
W45-1.4 NONINSULATED SERIES

ÜRÜN TEKNİK ÖZELLİKLERİ
PRODUCT'S TECHNICAL FEATURES

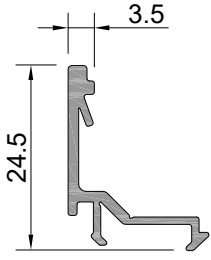

Profil No : W-511
Ağırlık : 187 gr/m

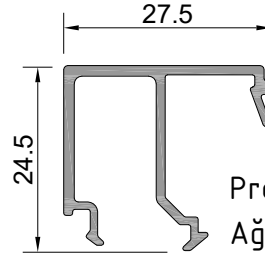

Profil No : W-517
Ağırlık : 299 gr/m

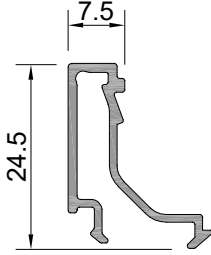

Profil No : W-512
Ağırlık : 206 gr/m

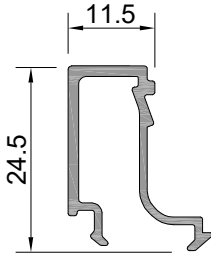

Profil No : W-513
Ağırlık : 227 gr/m

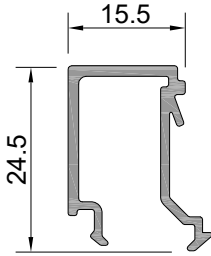

Profil No : W-514
Ağırlık : 252 gr/m

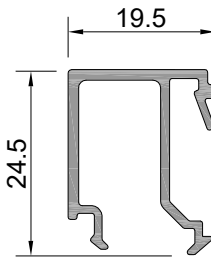

Profil No : W-515
Ağırlık : 273 gr/m

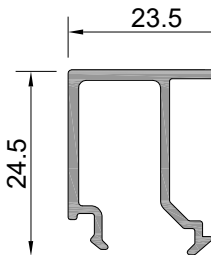

Profil No : W-516
Ağırlık : 286 gr/m

W10
W 45-1.4 YALITIMSIZ SERİ PROFİLLERİ
W45-1.4 NONINSULATED SERIES

CAM - FİTİL - CAM ÇİTASI
GLAZING-GASKET-GLAZING BELT

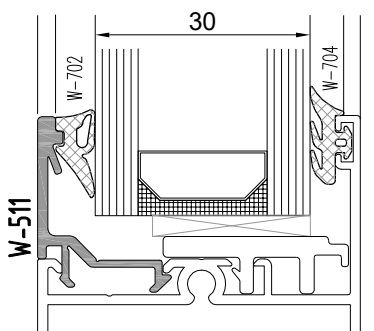
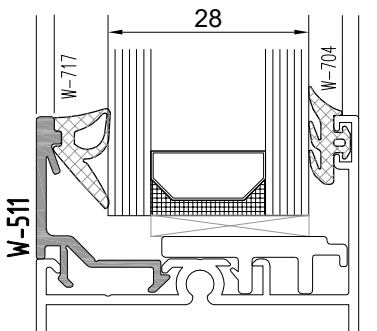
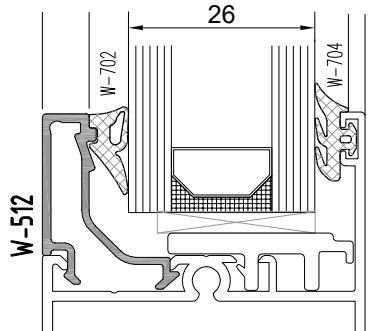
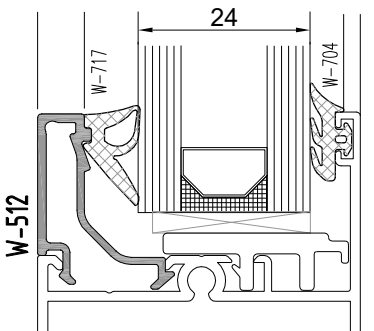
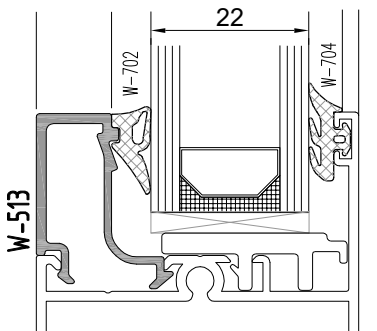
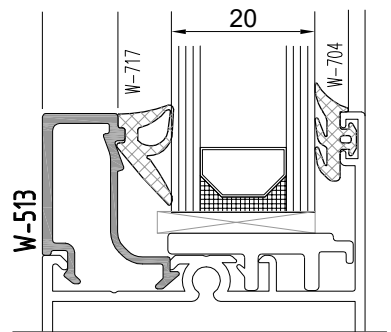
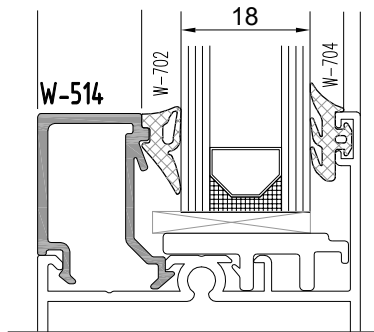
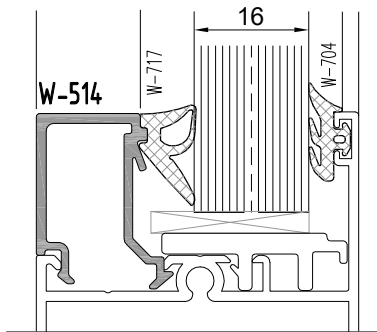
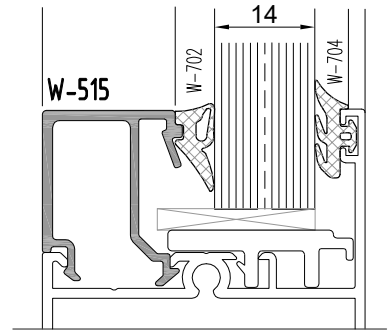
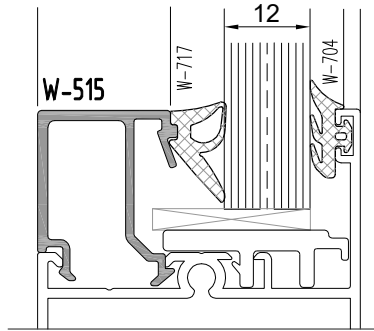
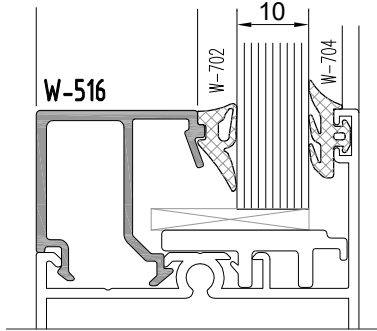
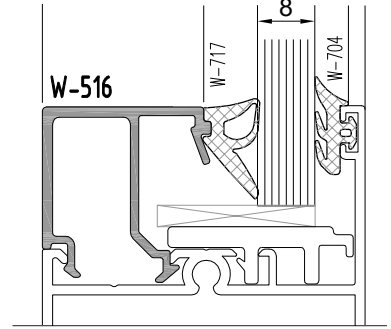
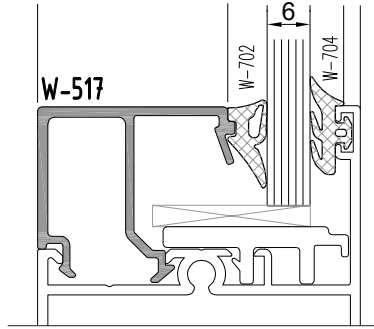
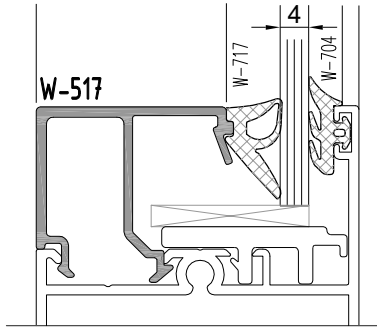

Profil değerleri teoriktir. Ağırlık olarak testimde yapılan tartım geçerlidir.
Profil imatları TS EN 12020-2 ve TS EN 755-9 toleransı,
Moment değerleri EN 14024'e göre hesaplanmıştır.

Profile values are theoretical pre-shipment weight will be valid.
The tolerances of Profile manufacturing are calculated according to EN 12020-2
and TS EN 755-9; moment values are calculated according to EN 14024.

W10
W 45-1.4 YALITIMSIZ SERİ PROFİLLERİ
W45-1.4 NONINSULATED SERIES

ÜRÜN TEKNİK ÖZELLİKLERİ
PRODUCT'S TECHNICAL FEATURES

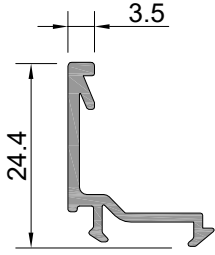

Profil No: W-511-a ⚠
Ağırlık : 193 gr/m

⚠ İşaretti profil için satış temsilcinizden bilgi alınır.

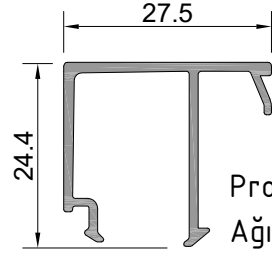

Profil No: W-517-a
Ağırlık : 284 gr/m

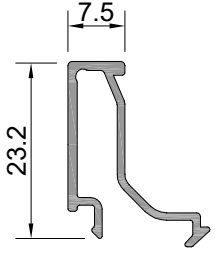

Profil No: W-512-a
Ağırlık : 194 gr/m

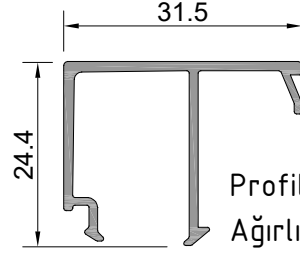

Profil No: W-518-a
Ağırlık : 297 gr/m

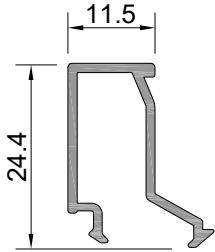

Profil No: W-513-a
Ağırlık : 216 gr/m

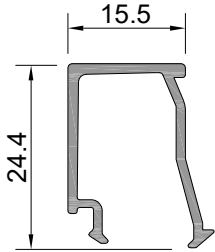

Profil No: W-514-a
Ağırlık : 228 gr/m

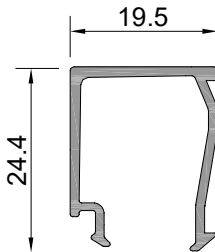

Profil No: W-515-a
Ağırlık : 242 gr/m

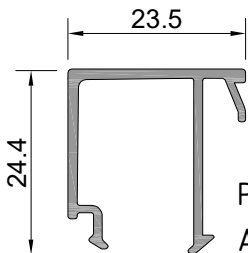

Profil No: W-516-a
Ağırlık : 270 gr/m

W10
W 45-1.4 YALITIMSIZ SERİ PROFİLLERİ
W45-1.4 NONINSULATED SERIES

CAM - FİTİL - CAM ÇİTASI
GLAZING-GASKET-GLAZING BELT

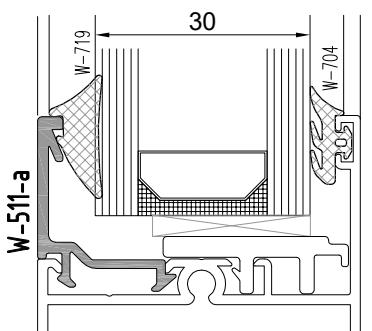
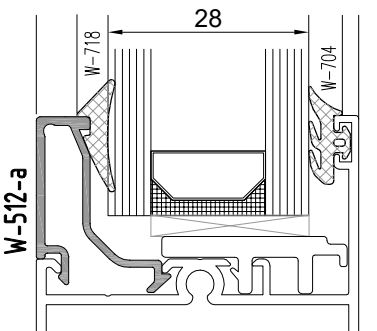
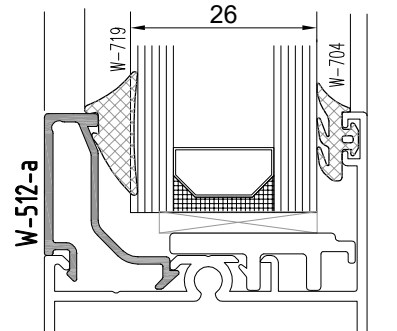
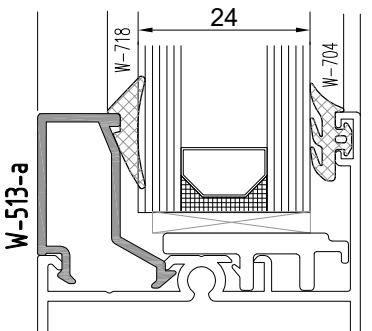
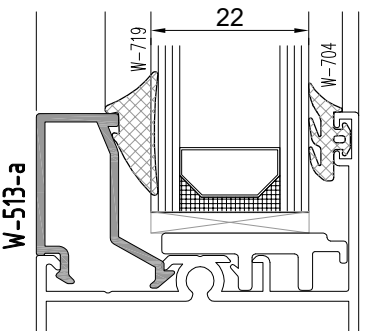
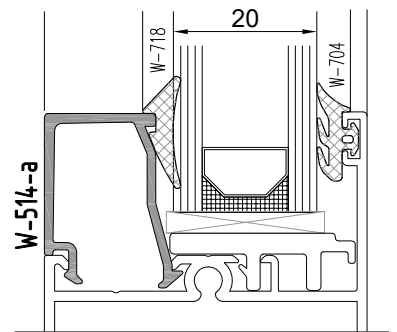
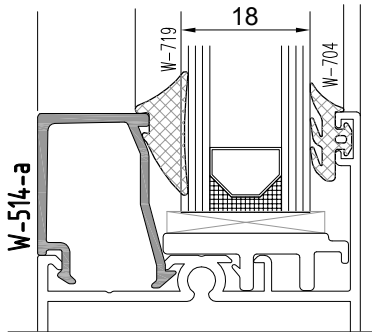
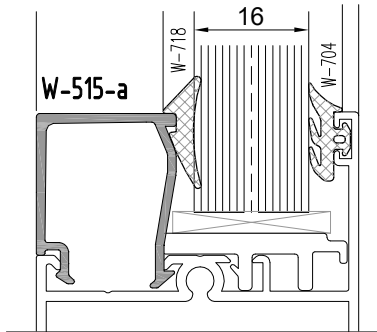
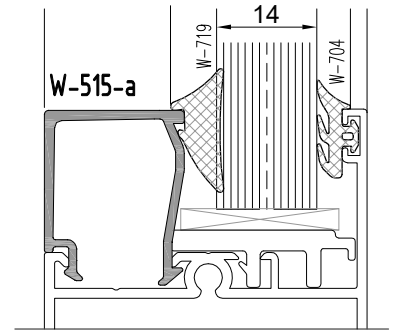
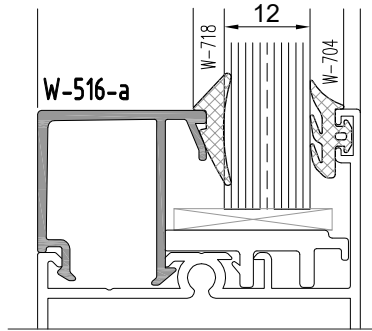
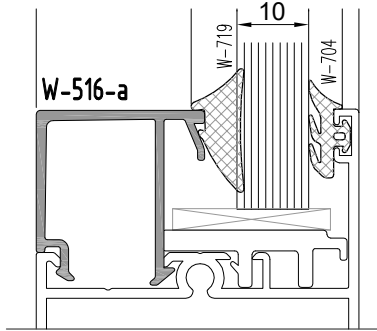
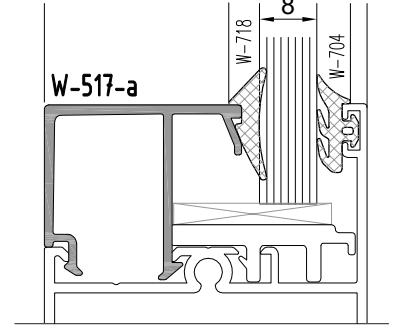
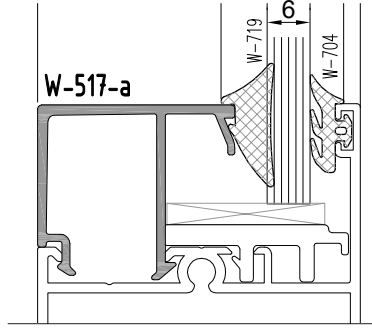
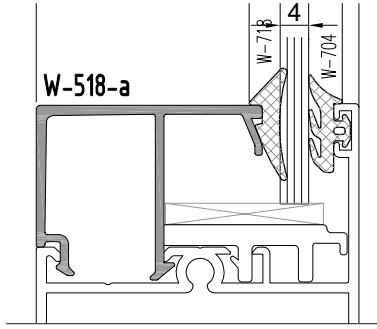

Profil değerleri teoriktir. Ağırlık olarak testimde yapılan tartım geçerlidir.
Profil imalatları TS EN 12020-2 ve TS EN 755-9 toleransları,
Moment değerleri EN 14024'e göre hesaplanmıştır.

Profile values are theoretical pre-shipment weight will be valid.
The tolerances of Profile manufacturing are calculated according to EN 12020-2
and TS EN 755-9; moment values are calculated according to EN 14024.

W10
W 45-1.4 YALITIMSIZ SERİ PROFİLLERİ
W45-1.4 NONINSULATED SERIES

ÜRÜN TEKNİK ÖZELLİKLERİ
PRODUCT'S TECHNICAL FEATURES

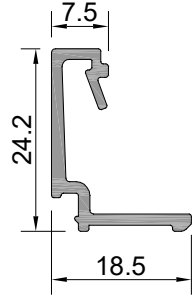

Profil No: W-512-B
Ağırlık : 227 gr/m

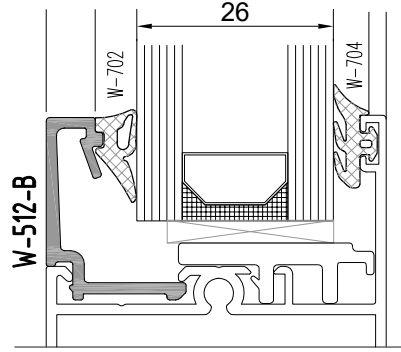
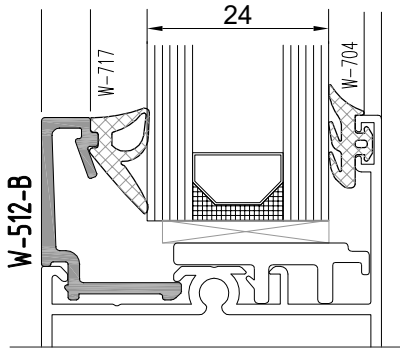

W10
W 45-1.4 YALITIMSIZ SERİ PROFİLLERİ
W45-1.4 NONINSULATED SERIES

ÜRÜN TEKNİK ÖZELLİKLERİ
PRODUCT'S TECHNICAL FEATURES

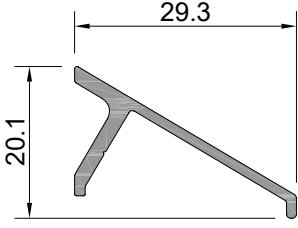

Profil No: **W-503**
Ağırlık : 211 gr/m

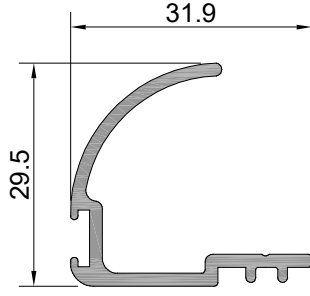

Profil No: **W-506** ⚠
Ağırlık : 363 gr/m
⚠ İşaretili profil için satış temsilcinizden bilgi alın.

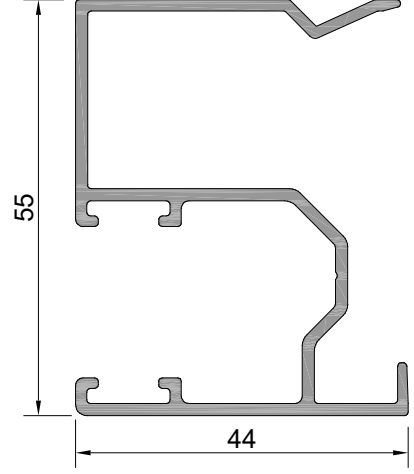

Profil No: **W-507** ⚠
Ağırlık : 834 gr/m
⚠ İşaretili profil için satış temsilcinizden bilgi alın.

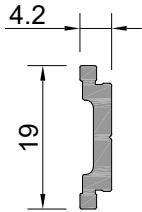

Profil No: **W1-508**
Ağırlık : 138 gr/m

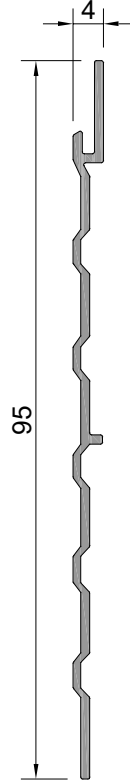

Profil No: **W-509**
Ağırlık : 319 gr/m

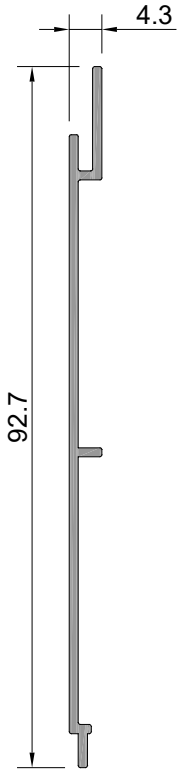

Profil No: **W-510**
Ağırlık : 342 gr/m

W10
W 45-1.4 YALITIMSIZ SERİ PROFİLLERİ
W45-1.4 NONINSULATED SERIES

ÜRÜN TEKNİK ÖZELLİKLERİ
PRODUCT'S TECHNICAL FEATURES

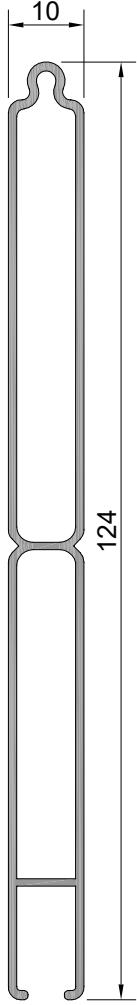

Profil No: W-521
Ağırlık : 805 gr/m

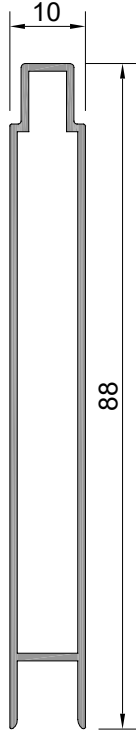

Profil No: W-522
Ağırlık : 519 gr/m

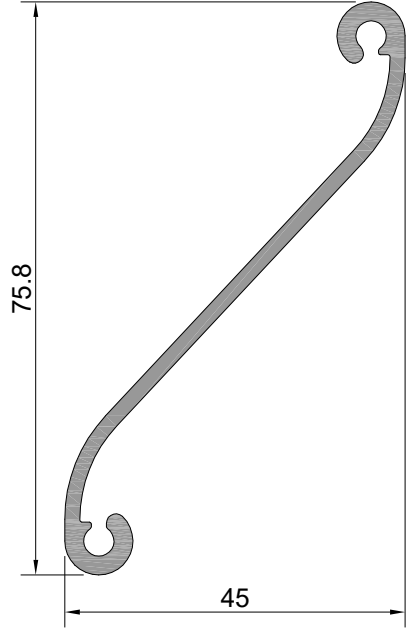

Profil No: W-523
Ağırlık : 647 gr/m

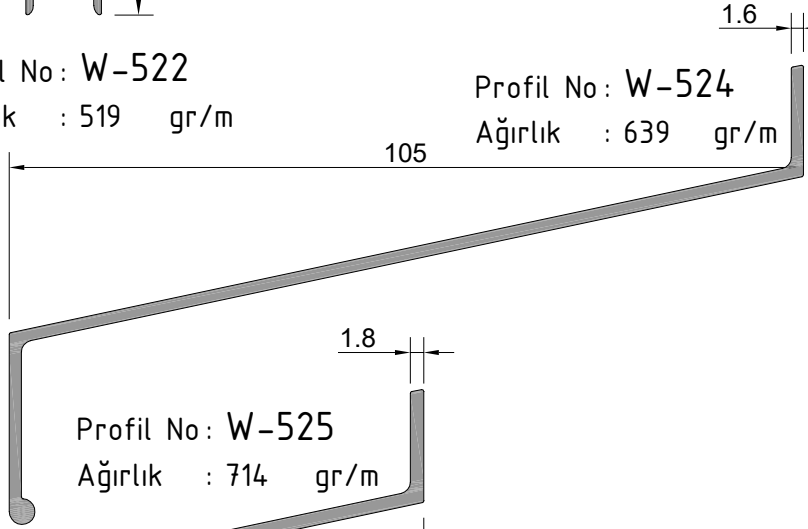

Profil No: W-524
Ağırlık : 639 gr/m

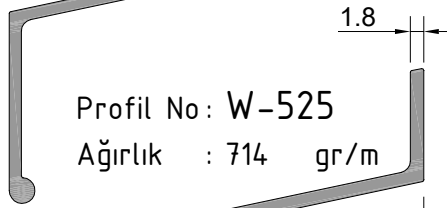

Profil No: W-525
Ağırlık : 714 gr/m

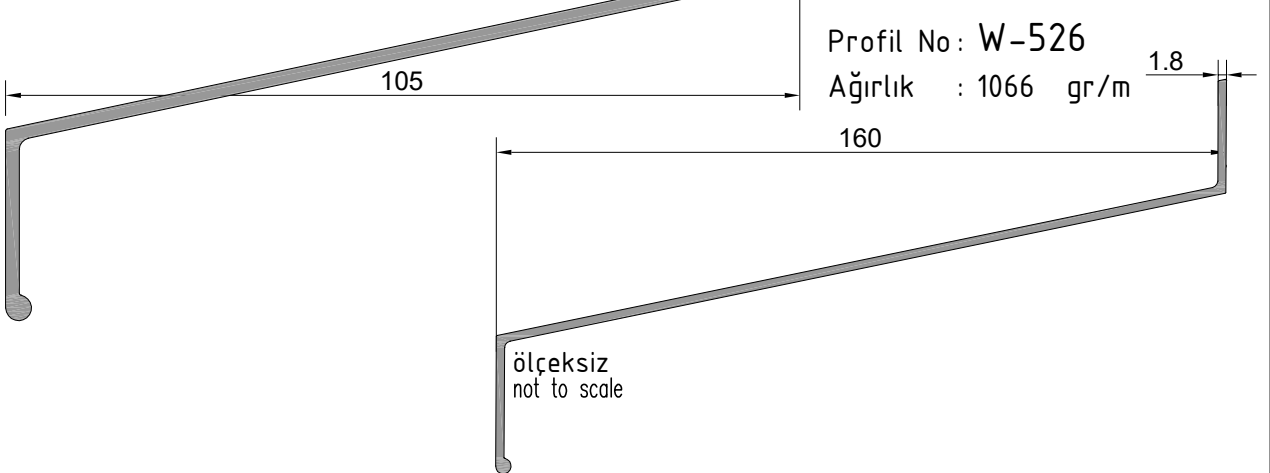

Profil No: W-526
Ağırlık : 1066 gr/m

W10
W 45-1.4 YALITIMSIZ SERİ PROFİLLERİ
W45-1.4 NONINSULATED SERIES

ÜRÜN TEKNİK ÖZELLİKLERİ
PRODUCT'S TECHNICAL FEATURES

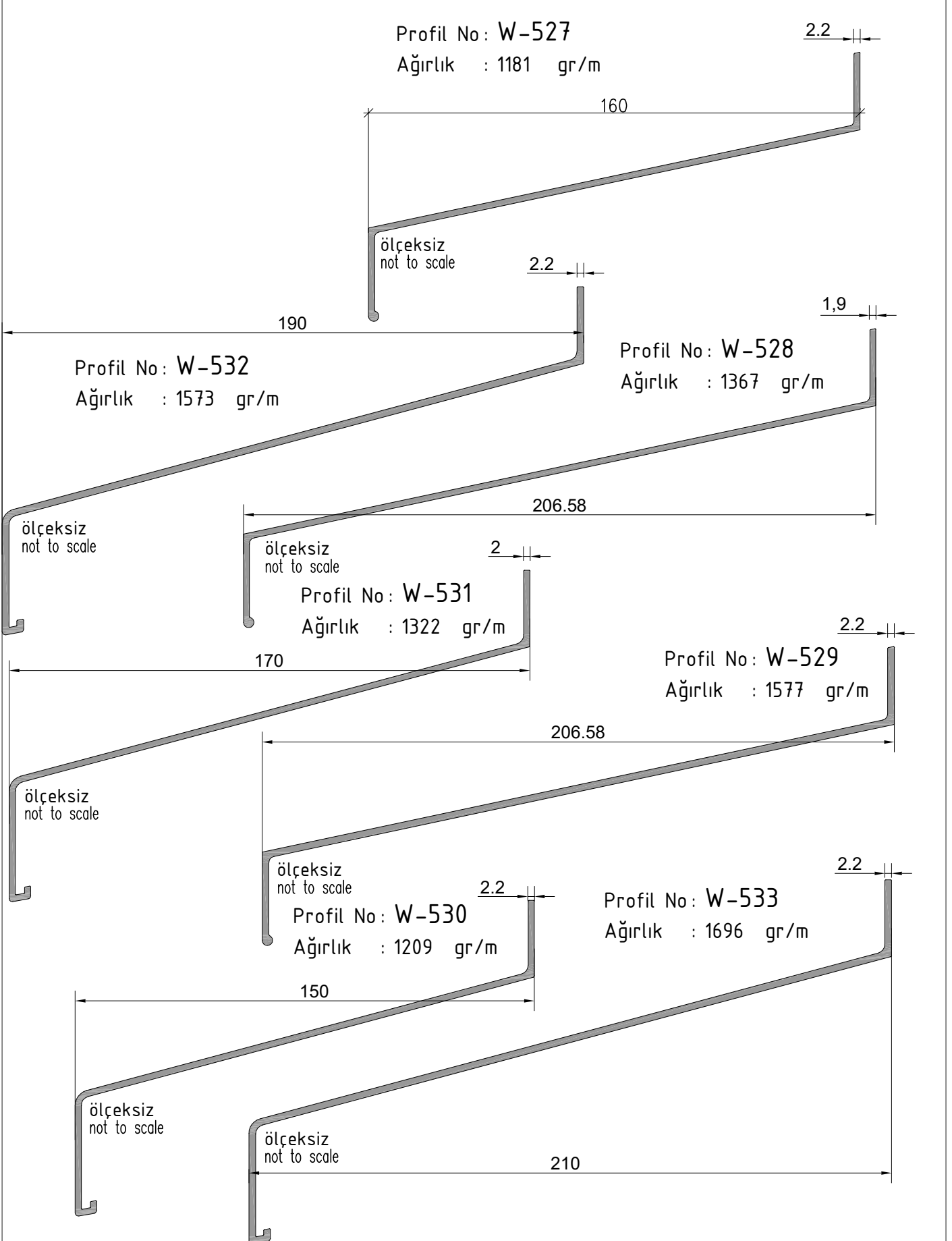

Profil değerleri teoriktir. Ağırlık olarak testimde yapılan tartım geçerlidir.
Profil imalatları TS EN 12020-2 ve TS EN 755-9 toleransı,
Moment değerleri EN 14024'e göre hesaplanmıştır.

Profile values are theoretical pre-shipment weight will be valid.
The tolerances of Profile manufacturing are calculated according to EN 12020-2
and TS EN 755-9; moment values are calculated according to EN 14024.

W10
W 45-1.4 YALITIMSIZ SERİ PROFİLLERİ
W45-1.4 NONINSULATED SERIES

ÜRÜN TEKNİK ÖZELLİKLERİ
PRODUCT'S TECHNICAL FEATURES

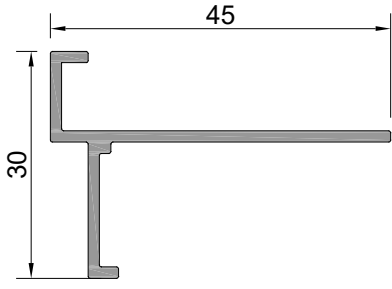

Profil No : W-534
Ağırlık : 328 gr/m

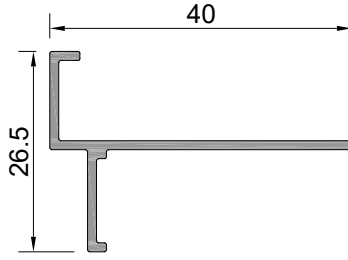

Profil No : W-535
Ağırlık : 229 gr/m

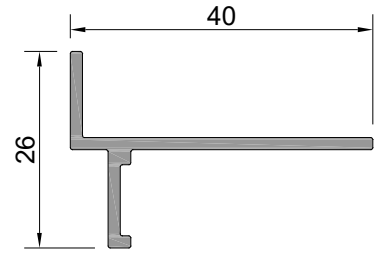

Profil No : W-536
Ağırlık : 292 gr/m

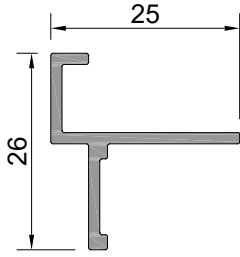

Profil No : W-537
Ağırlık : 226 gr/m

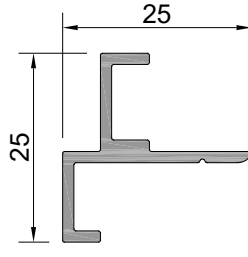

Profil No : W-538
Ağırlık : 249 gr/m

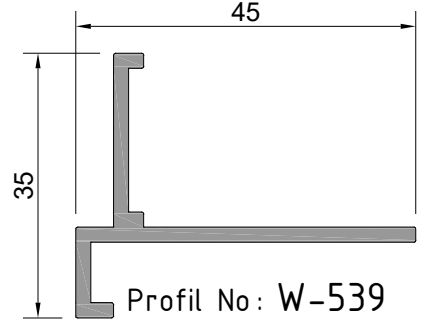

Profil No : W-539
Ağırlık : 460 gr/m

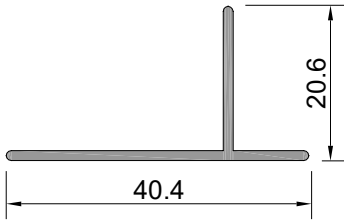

Profil No : W-540
Ağırlık : 208 gr/m

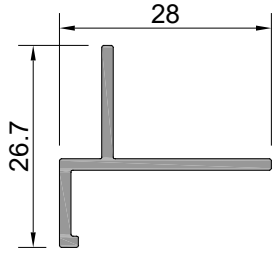

Profil No : W-541
Ağırlık : 219 gr/m

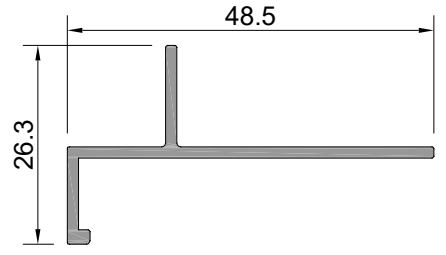

Profil No : W-542
Ağırlık : 306 gr/m

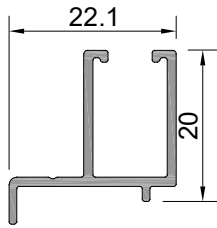

Profil No : W-543 ⚠
Ağırlık : 213 gr/m

⚠ İşaretti profil için satış temsilcimizden bilgi alınır.

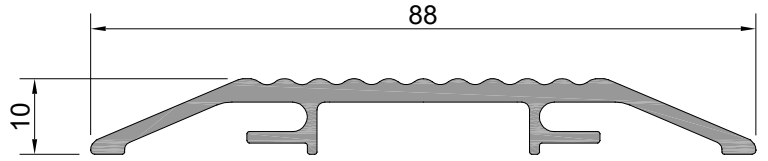

Profil No : W-544
Ağırlık : 728 gr/m

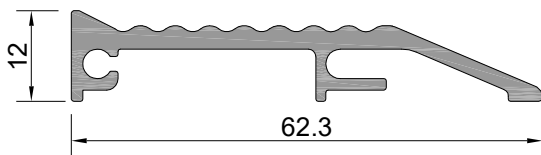

Profil No : W-545
Ağırlık : 578 gr/m

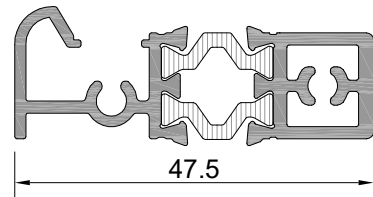

Profil No : W-555
Ağırlık PVC : 767 gr/m
Ağırlık POLY : 758 gr/m

W10
W 45-1.4 YALITIMSIZ SERİ PROFİLLERİ
W45-1.4 NONINSULATED SERIES

ÜRÜN TEKNİK ÖZELLİKLERİ
PRODUCT'S TECHNICAL FEATURES

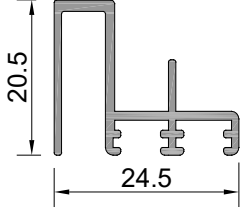

Profil No : W-557
Ağırlık : 260 gr/m

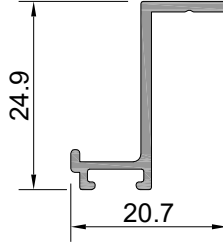

Profil No : W-558
Ağırlık : 173 gr/m

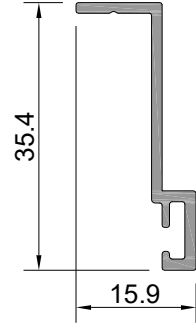

Profil No : W-559
Ağırlık : 216 gr/m

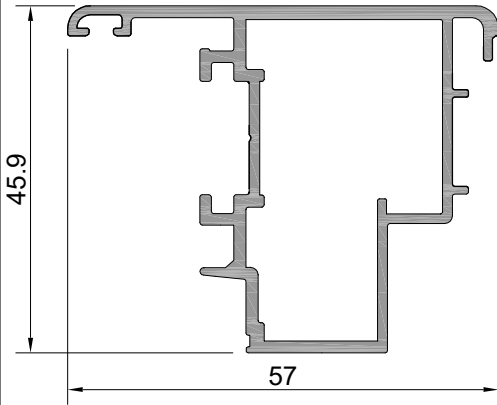

Profil No : W10-503
Ağırlık : 859 gr/m

⚠ İşaretti profil için satış temsilcilerinizden bilgi alınız.

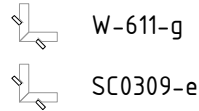

W-611-g

SC0309-e

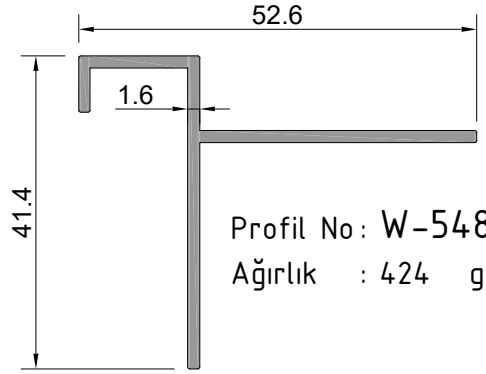

Profil No : W-548
Ağırlık : 424 gr/m

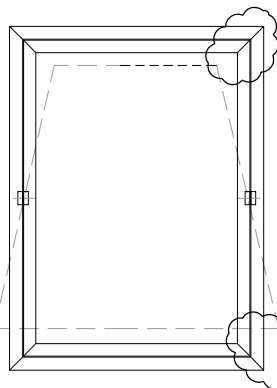

W-611-g

SC0307-g

ALTERNATIVE 1

ALTERNATIVE 2

W10
W 45-1.4 YALITIMSIZ SERİ PROFİLLERİ
W45-1.4 NONINSULATED SERIES

ÜRÜN TEKNİK ÖZELLİKLERİ
PRODUCT'S TECHNICAL FEATURES

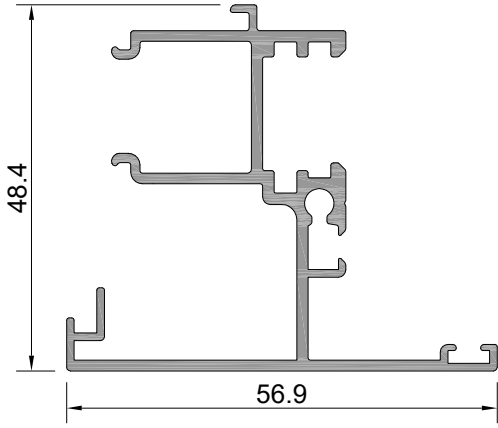

Profil No: W10-501
Ağırlık : 795 gr/m

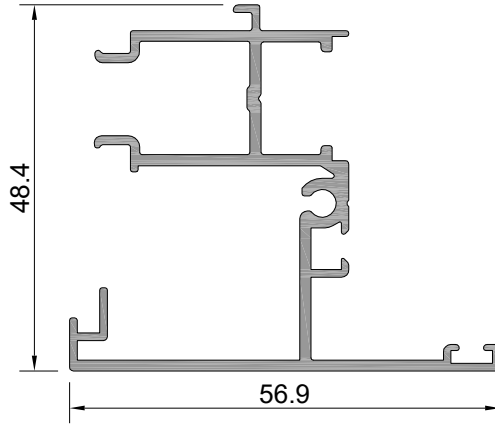

Profil No: W10-501-a
Ağırlık : 799 gr/m

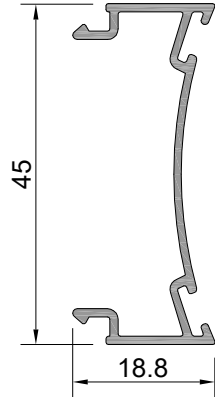

Profil No: W10-504 ⚠
Ağırlık : 285 gr/m

⚠ İşaretti profil için satış temsilcinizden bilgi alınız.

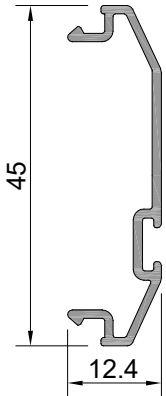

Profil No: W10-505
Ağırlık : 239 gr/m

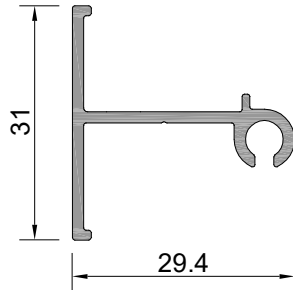

Profil No: W10-508
Ağırlık : 300 gr/m

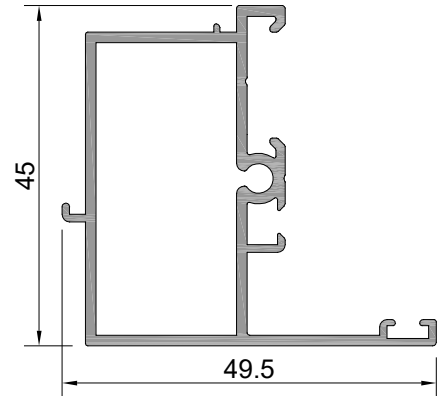

Profil No: W10-510
Ağırlık : 686 gr/m

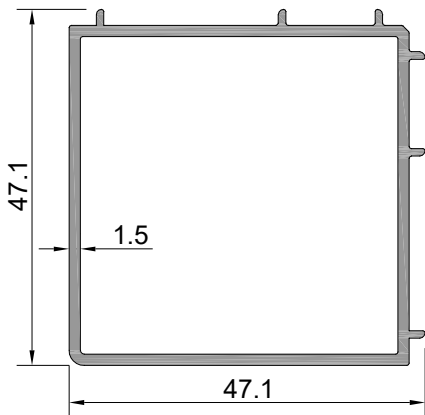

Profil No: W10-550
Ağırlık : 736 gr/m

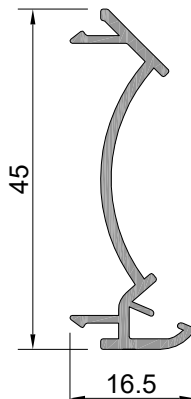

Profil No: W10-620
Ağırlık : 292 gr/m

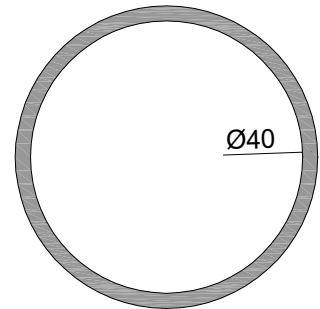

Profil No: W10-630 ⚠
Ağırlık : 647 gr/m

⚠ İşaretti profil için satış temsilcinizden bilgi alınız.

W10
W 45-1.4 YALITIMSIZ SERİ PROFİLLERİ
W45-1.4 NONINSULATED SERIES

ÜRÜN TEKNİK ÖZELLİKLERİ
PRODUCT'S TECHNICAL FEATURES

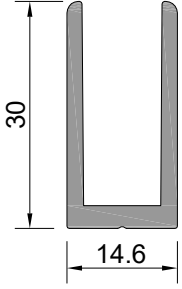

Profil No : W10-621
Ağırlık : 423 gr/m

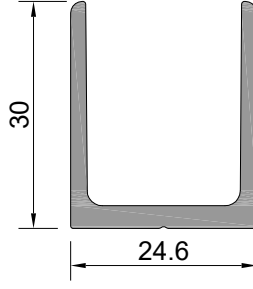

Profil No : W10-622 ⚠
Ağırlık : 508 gr/m
⚠ İşaretti profil için satış temsilcinizden bilgi alınız.

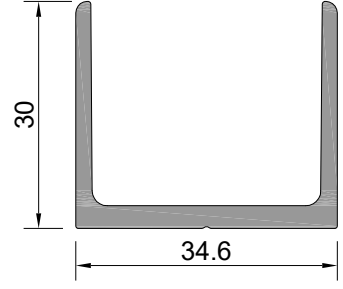

Profil No : W10-623 ⚠
Ağırlık : 590 gr/m
⚠ İşaretti profil için satış temsilcinizden bilgi alınız.

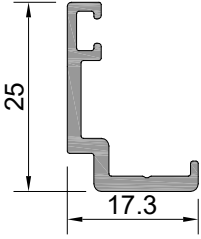

Profil No : W4-504
Ağırlık : 227 gr/m

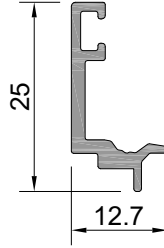

Profil No : W4-505
Ağırlık : 184 gr/m

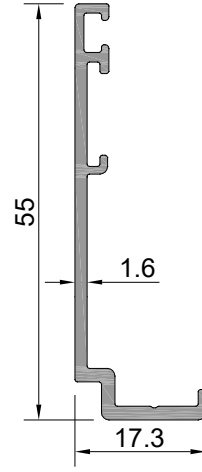

Profil No : W4-508
Ağırlık : 356 gr/m

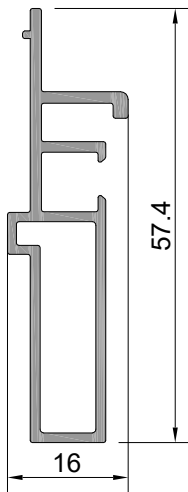

Profil No : W3-511 ⚠
Ağırlık : 496 gr/m
⚠ İşaretti profil için satış temsilcinizden bilgi alınız.

W10
W 45-1.4 YALITIMSIZ SERİ PROFİLLERİ
W45-1.4 NONINSULATED SERIES

ÜRÜN TEKNİK ÖZELLİKLERİ
PRODUCT'S TECHNICAL FEATURES

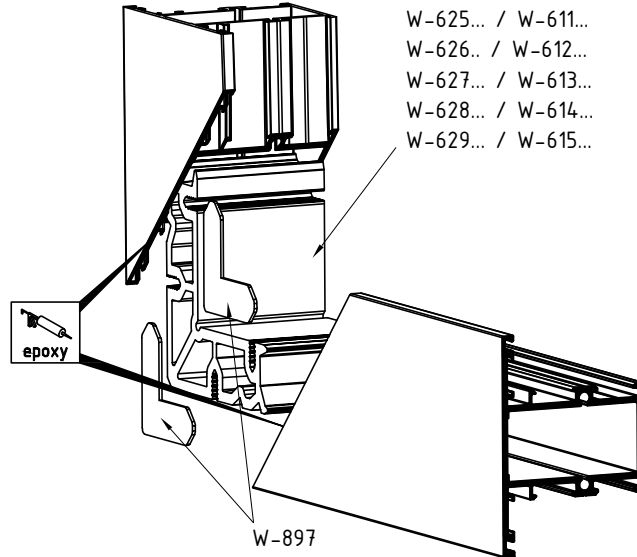
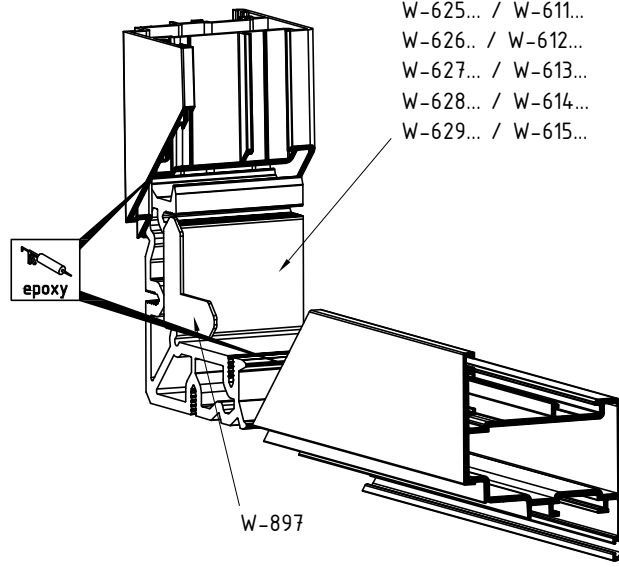
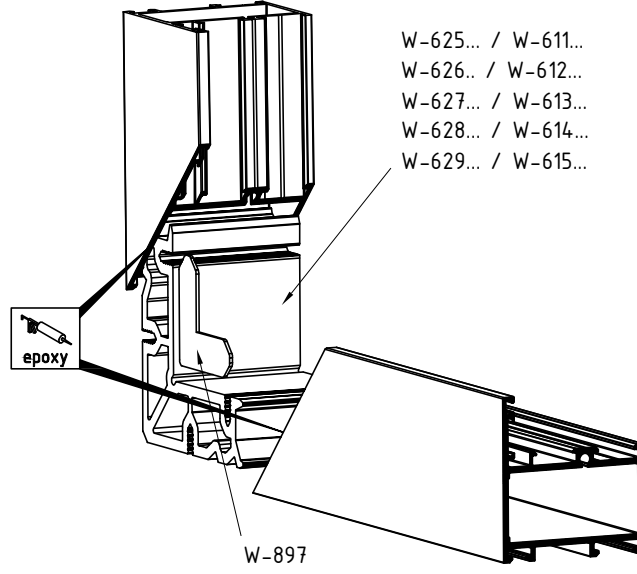

W10

W 45-1.4 YALITIMSIZ SERİ PROFİLLERİ

W45-1.4 NONINSULATED SERIES

ÜRÜN TEKNİK ÖZELLİKLERİ
PRODUCT'S TECHNICAL FEATURES

Profil No : W-625 

Ağırlık : 1560 gr/m

 İşaretili profil için satış temsilcinizden bilgi alınır.

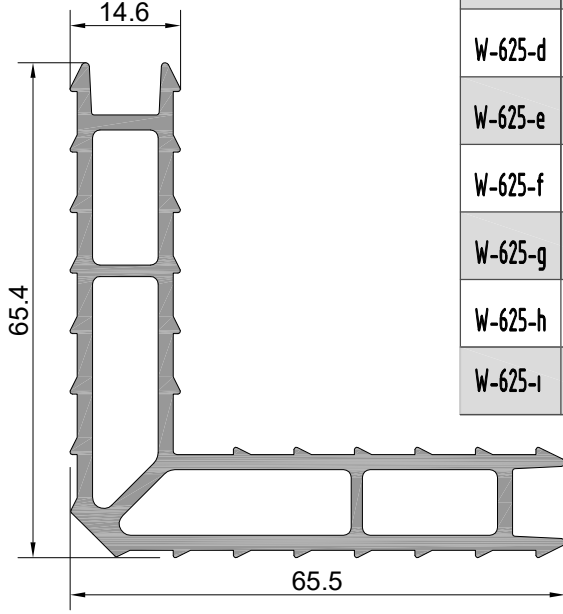

W-625-a	W-611-a	8.2mm	100 adet/pcs
W-625-b	W-611-b	23.6mm	100 adet/pcs
W-625-c	W-611-c	6mm	100 adet/pcs
W-625-d	W-611-d	25.3mm	100 adet/pcs
W-625-e	W-611-e	50.1mm	100 adet/pcs
W-625-f	W-611-f	50.6mm	100 adet/pcs
W-625-g	W-611-g	41.7mm	100 adet/pcs
W-625-h	W-611-h	36.5mm	100 adet/pcs
W-625-ı	W-611-ı	4.7mm	100 adet/pcs

Profil No : W-611

Ağırlık : 2520 gr/m

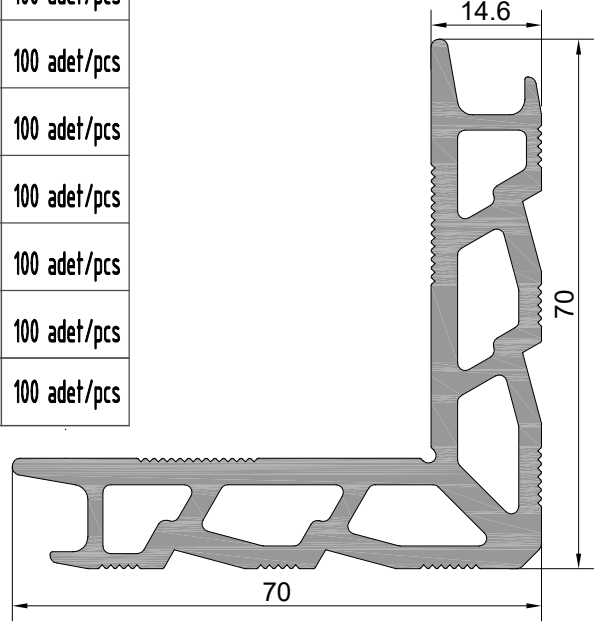

Profil No : W-626

Ağırlık : 1762 gr/m

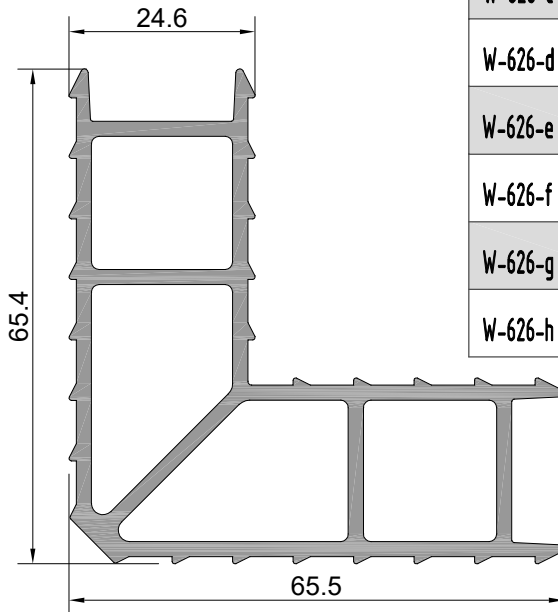

W-626-a	W-612-a	8.2mm	100 adet/pcs
W-626-b	W-612-b	23.6mm	100 adet/pcs
W-626-c	W-612-c	6mm	100 adet/pcs
W-626-d	W-612-d	25.3mm	100 adet/pcs
W-626-e	W-612-e	50.1mm	100 adet/pcs
W-626-f	W-612-f	50.6mm	100 adet/pcs
W-626-g	W-612-g	4.7mm	100 adet/pcs
W-626-h	W-612-h	41.8mm	100 adet/pcs

Profil No : W-612

Ağırlık : 3524 gr/m

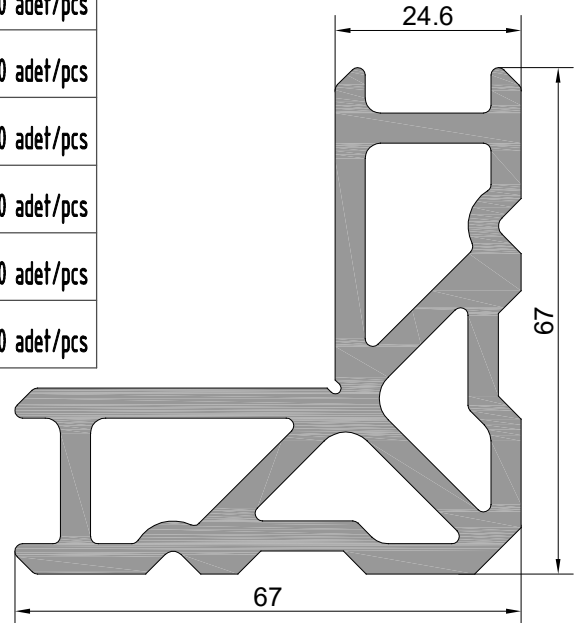

W10

W 45-1.4 YALITIMSIZ SERİ PROFİLLERİ

W45-1.4 NONINSULATED SERIES

ÜRÜN TEKNİK ÖZELLİKLERİ
PRODUCT'S TECHNICAL FEATURES

Profil No : W-627 

Ağırlık : 2091 gr/m

 İşaretili profil için satış temsilcilerinizden bilgi alın.

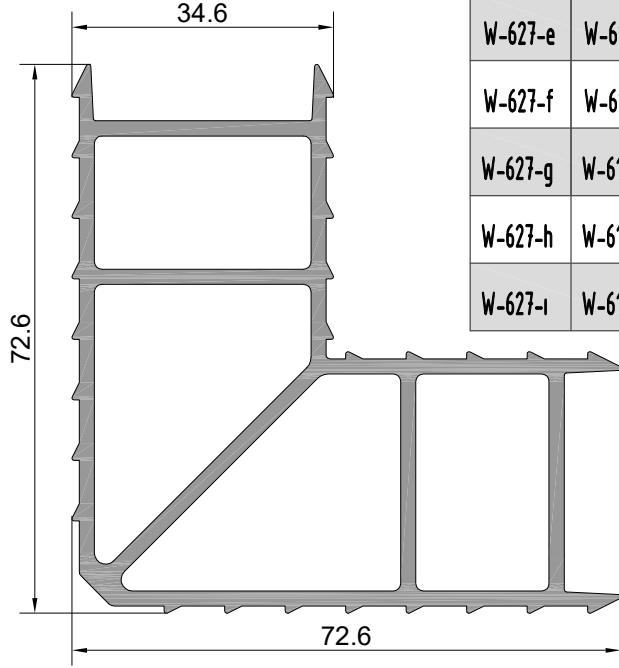

W-627-a	W-613-a	8.2mm	50 adet/pcs
W-627-b	W-613-b	23.6mm	50 adet/pcs
W-627-c	W-613-c	6mm	50 adet/pcs
W-627-d	W-613-d	25.3mm	50 adet/pcs
W-627-e	W-613-e	50.1mm	50 adet/pcs
W-627-f	W-613-f	5.3mm	50 adet/pcs
W-627-g	W-613-g	4.7mm	50 adet/pcs
W-627-h	W-613-h	7.5mm	50 adet/pcs
W-627-i	W-613-i	41.8mm	50 adet/pcs

Profil No : W-613

Ağırlık : 3945 gr/m

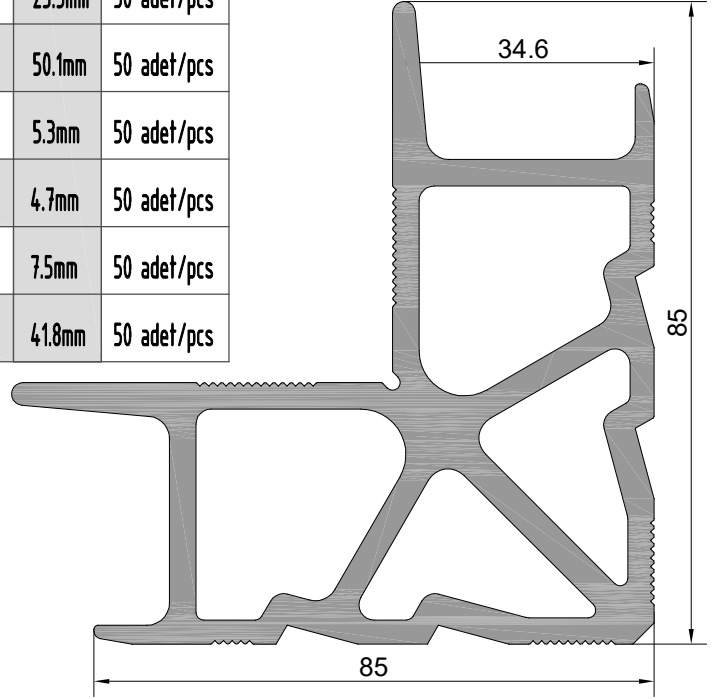

Profil No : W-628

Ağırlık : 2451 gr/m

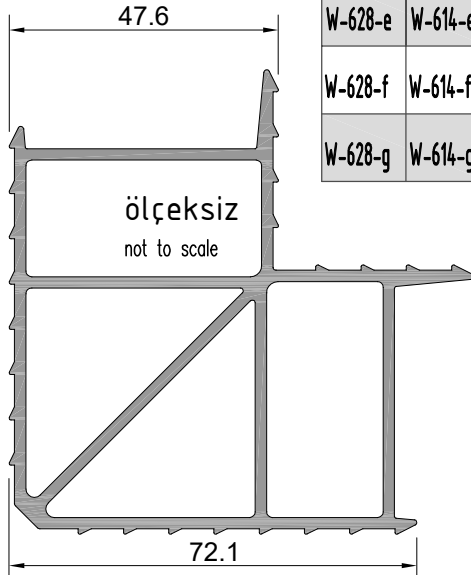

W-628-a	W-614-a	6mm	25 adet/pcs	W-628-h	W-614-h	20mm	25 adet/pcs
W-628-b	W-614-b	25.3mm	25 adet/pcs	W-628-i	W-614-i	5.3mm	25 adet/pcs
W-628-c	W-614-c	23.4mm	25 adet/pcs	W-628-j	W-614-j	43.3mm	25 adet/pcs
W-628-d	W-614-d	14mm	25 adet/pcs	W-628-k	W-614-k	7.5mm	25 adet/pcs
W-628-e	W-614-e	50.1mm	25 adet/pcs	W-628-l	W-614-l	18.6mm	25 adet/pcs
W-628-f	W-614-f	50.6mm	25 adet/pcs	W-628-m	W-614-m	11.9mm	25 adet/pcs
W-628-g	W-614-g	42.1mm	25 adet/pcs	W-628-n	W-614-n	41.8mm	25 adet/pcs
				W-628-o	W-614-o	8.5mm	25 adet/pcs

Profil No : W-614

Ağırlık : 5318 gr/m

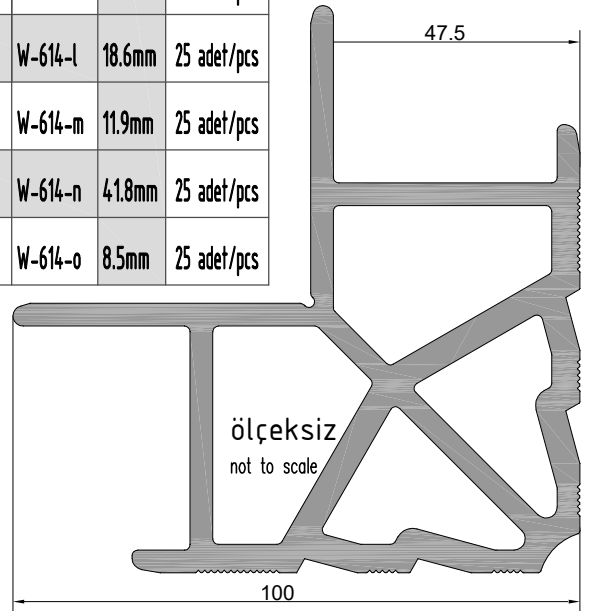

W10
W 45-1.4 YALITIMSIZ SERİ PROFİLLERİ
W45-1.4 NONINSULATED SERIES

ÜRÜN TEKNİK ÖZELLİKLERİ
PRODUCT'S TECHNICAL FEATURES

Profil No: W-629 

Ağırlık : 3090 gr/m

 İşaretili profil için satış temsilcilerinizden bilgi alınız.

W-629-a	W-615-a	6mm	25 adet/pcs
W-629-b	W-615-b	25.3mm	25 adet/pcs
W-629-c	W-615-c	23.3mm	25 adet/pcs
W-629-d	W-615-d	14mm	25 adet/pcs
W-629-e	W-615-e	50.1mm	25 adet/pcs
W-629-f	W-615-f	50.6mm	25 adet/pcs
W-629-g	W-615-g	42.1mm	25 adet/pcs
W-629-h	W-615-h	18.6mm	25 adet/pcs
W-629-ı	W-615-ı	11.9mm	25 adet/pcs
W-629-j	W-615-j	4.7mm	25 adet/pcs
W-629-k	W-615-k	41.8mm	25 adet/pcs

Profil No: W-615

Ağırlık : 6313 gr/m

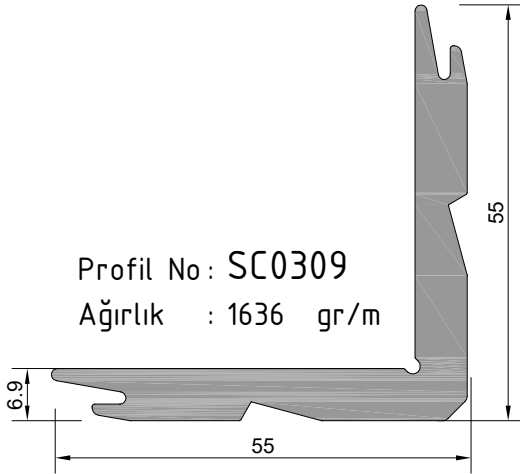
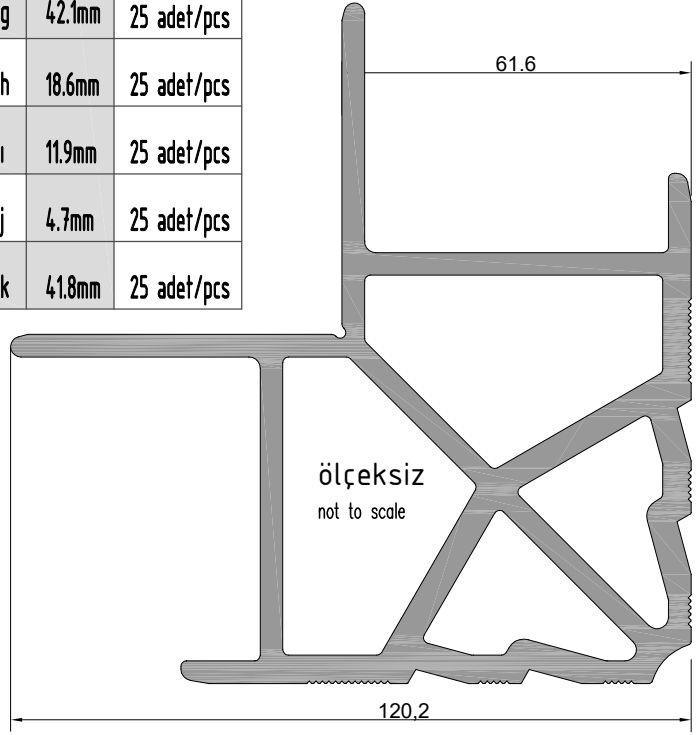
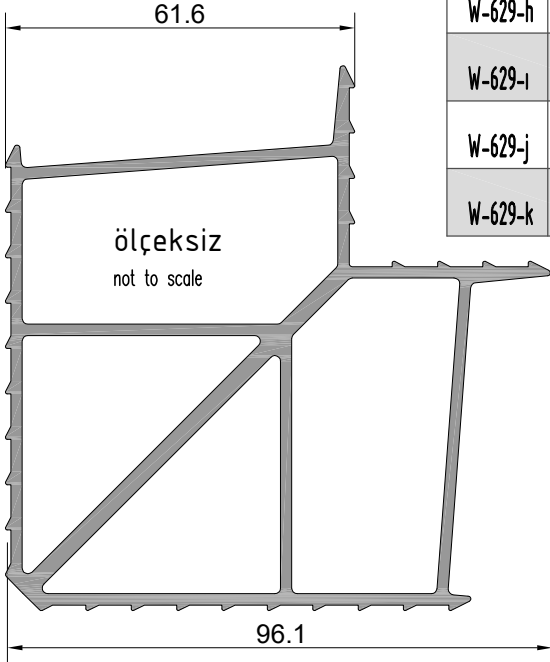

SC0309-a	6.5mm	100 adet/pcs
SC0309-b	8.5mm	100 adet/pcs
SC0309-c	18.9mm	100 adet/pcs
SC0309-d	20mm	100 adet/pcs
SC0309-e	25.3mm	100 adet/pcs

SC0309-f	4.7mm	100 adet/pcs
SC0309-g	54.2mm	100 adet/pcs
SC0309-h	23.8mm	100 adet/pcs
SC0309-ı	48.2mm	100 adet/pcs

W10
W 45-1.4 YALITIMSIZ SERİ PROFİLLERİ
W45-1.4 NONINSULATED SERIES

ÜRÜN TEKNİK ÖZELLİKLERİ
PRODUCT'S TECHNICAL FEATURES

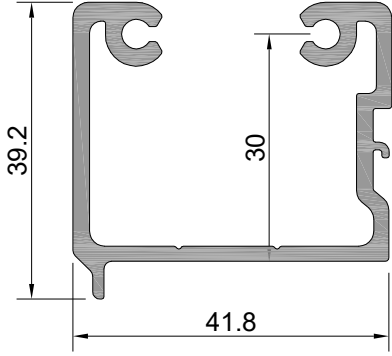

W10-609-a	14.6mm	100 adet/pcs
W10-609-b	24.6mm	100 adet/pcs
W10-609-c	34.6mm	100 adet/pcs
W10-609-d	55.6mm	100 adet/pcs
W10-609-e	80.3mm	100 adet/pcs
W10-609-f	110.6mm	100 adet/pcs

Profil No : W10-609

Ağırlık : 902 gr/m

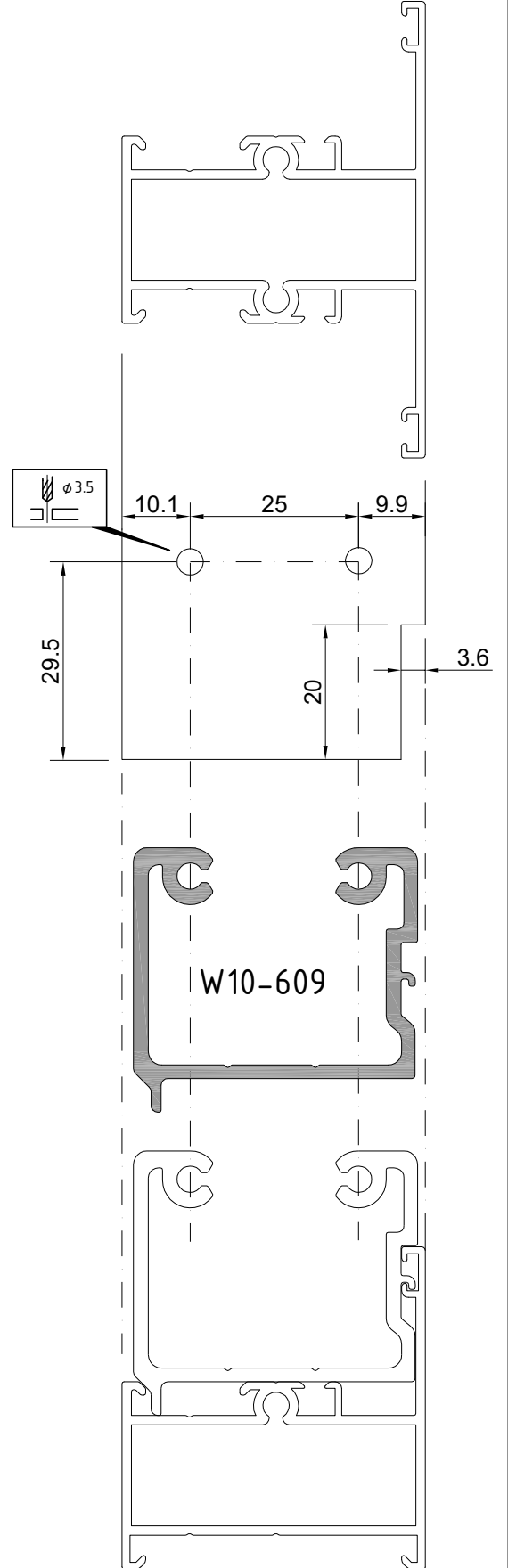
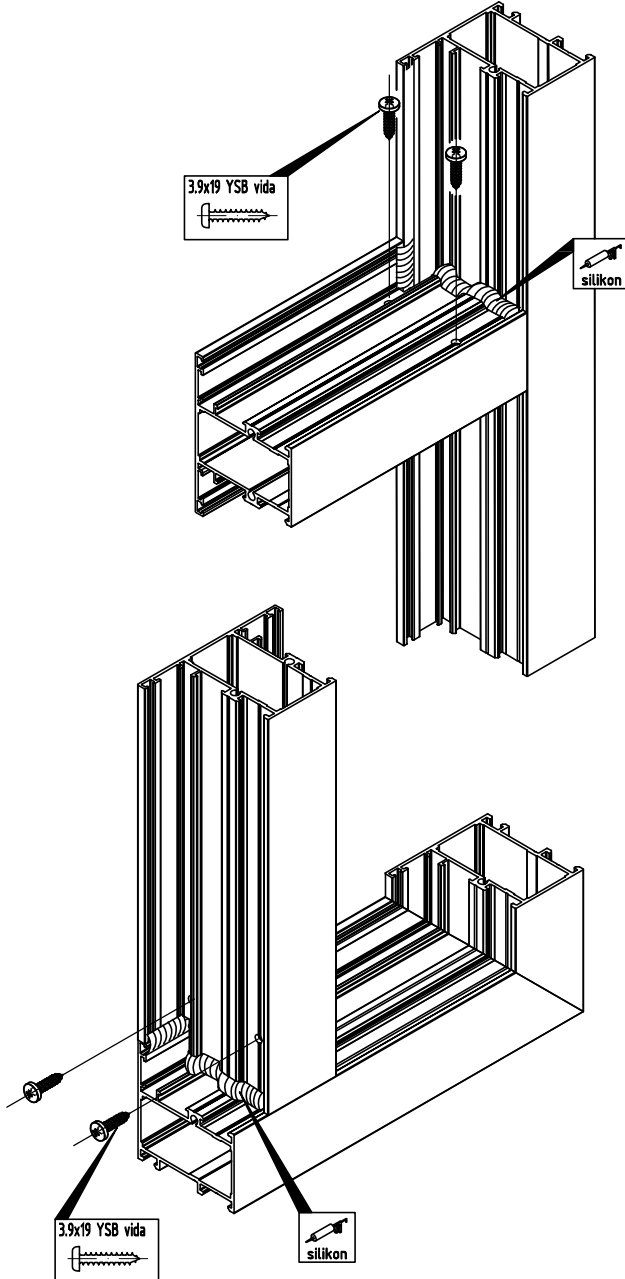

W10
W 45-1.4 YALITIMSIZ SERİ PROFİLLERİ
W45-1.4 NONINSULATED SERIES

YAN BİTİM DETAYI
WALL CONNECTION DETAIL

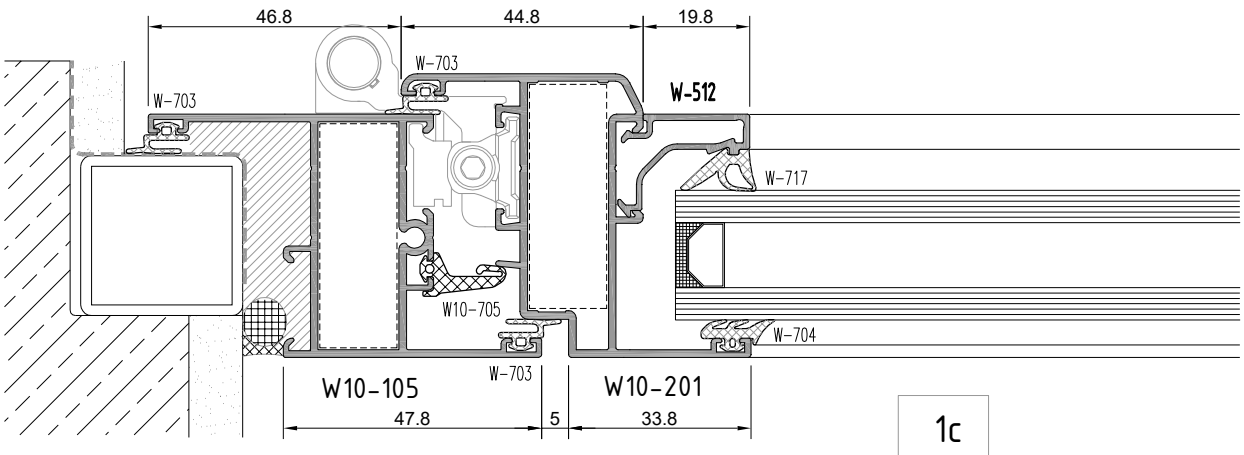
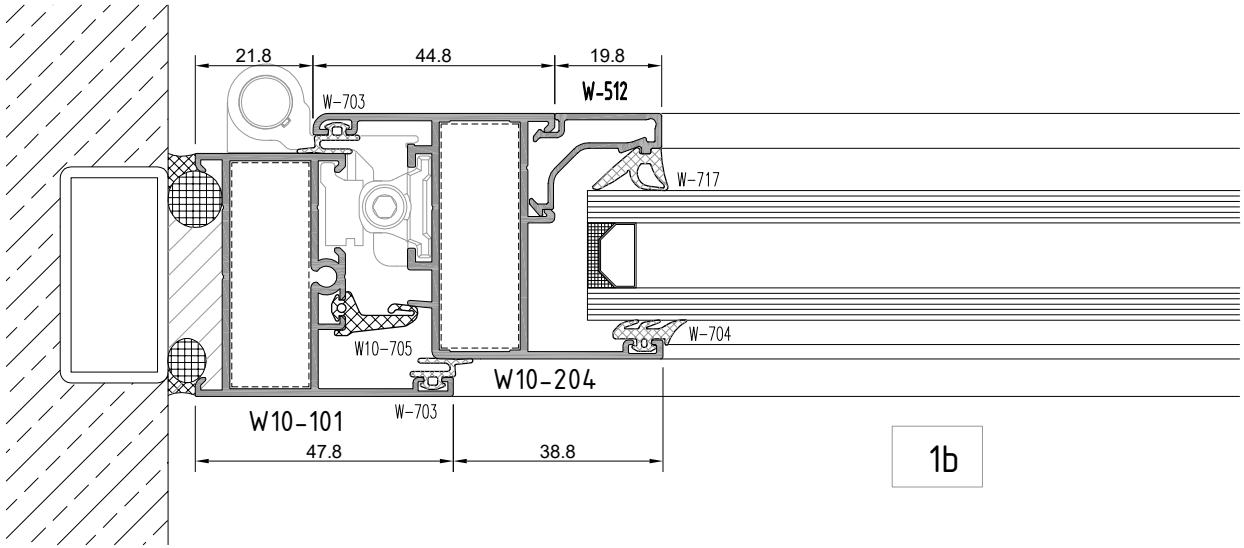
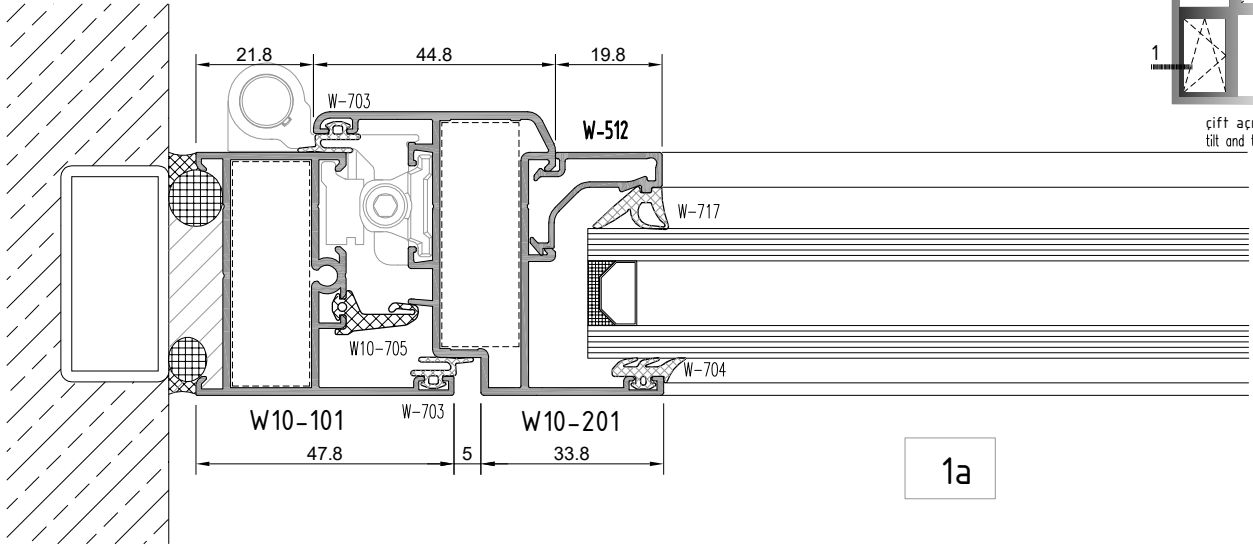

not to scale

W10
W 45-1.4 YALITIMSIZ SERİ PROFİLLERİ
W45-1.4 NONINSULATED SERIES

YAN BİTİM DETAYI
WALL CONNECTION DETAIL

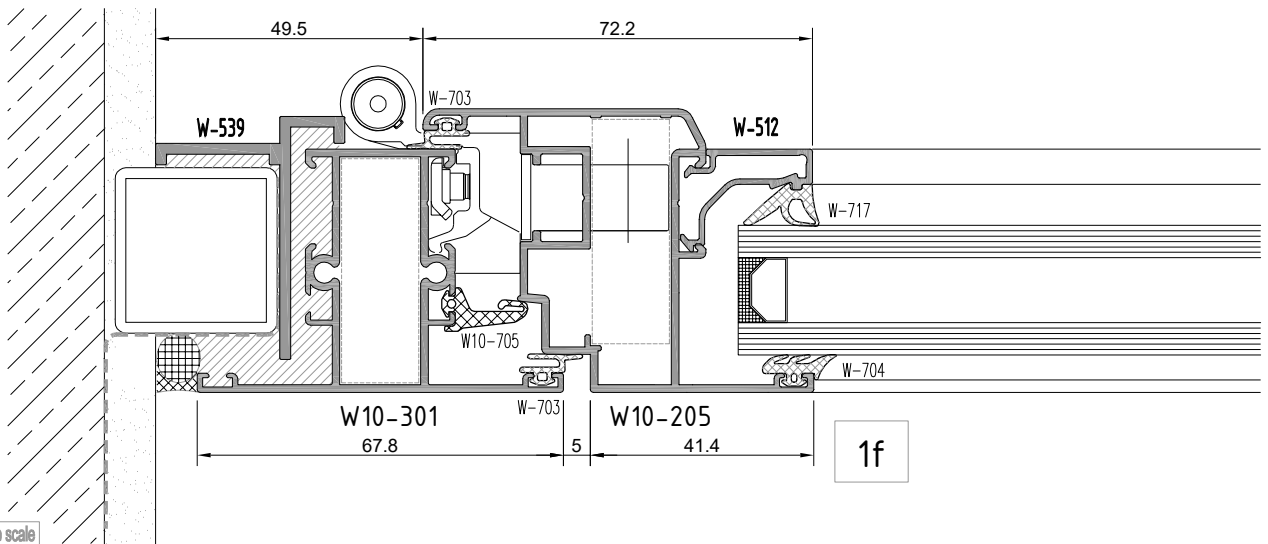
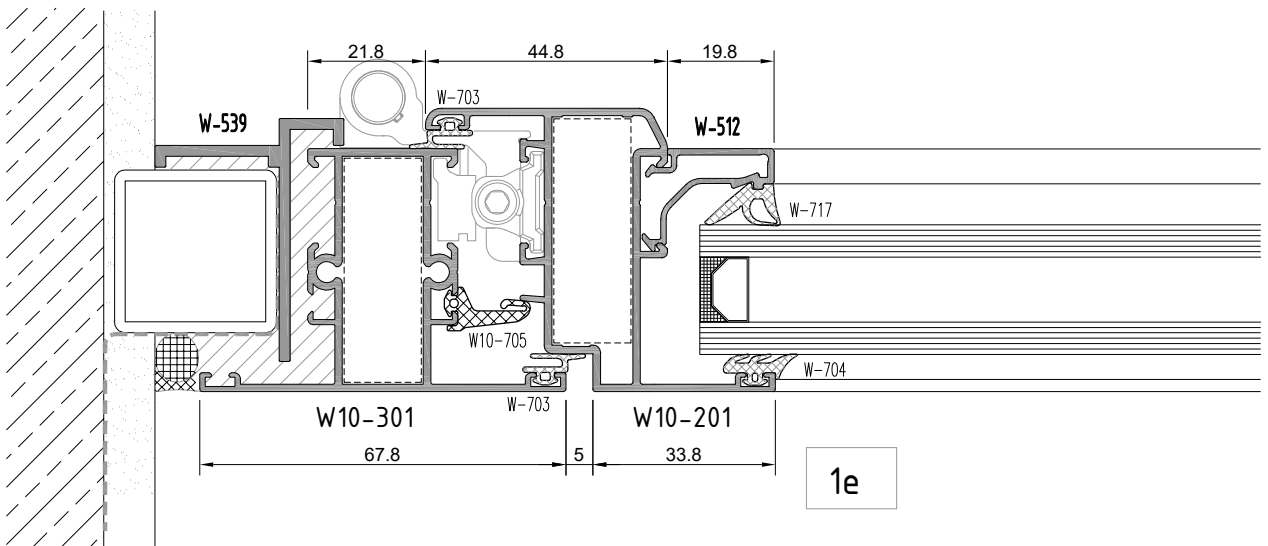
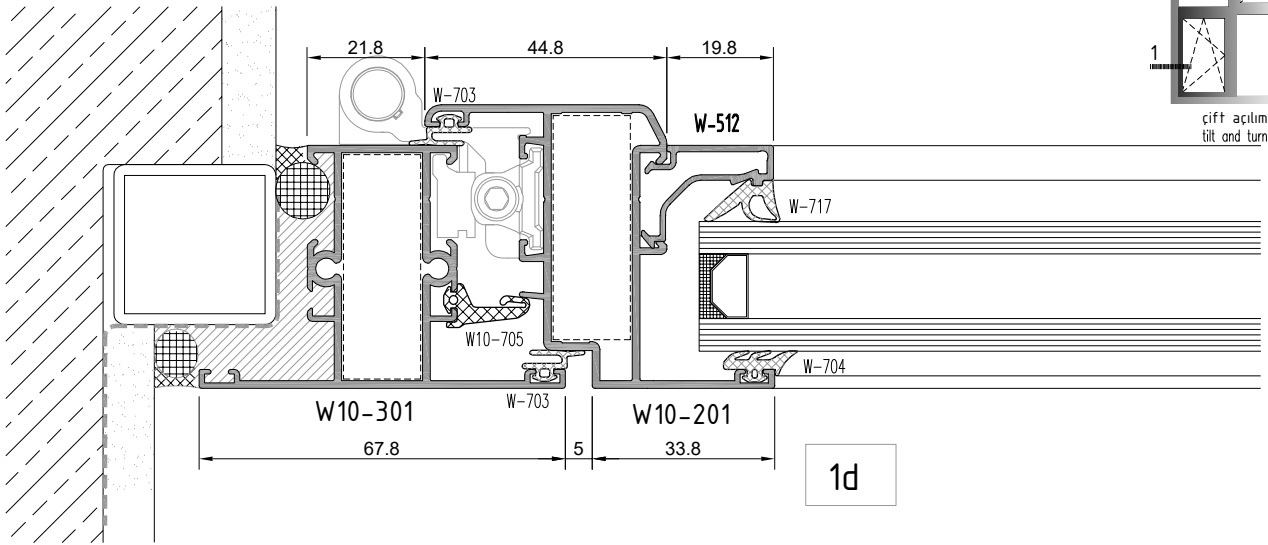

not to scale

W10
W 45-1.4 YALITIMSIZ SERİ PROFİLLERİ
 W45-1.4 NONINSULATED SERIES

ORTA KAYIT DETAYI
 MULLION DETAIL

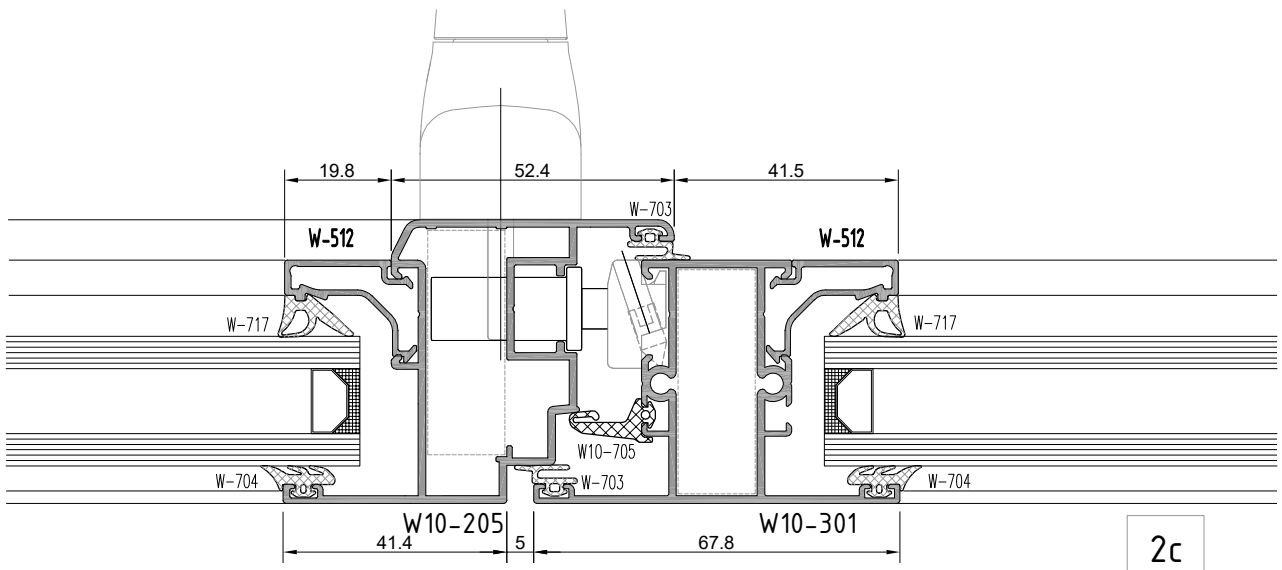
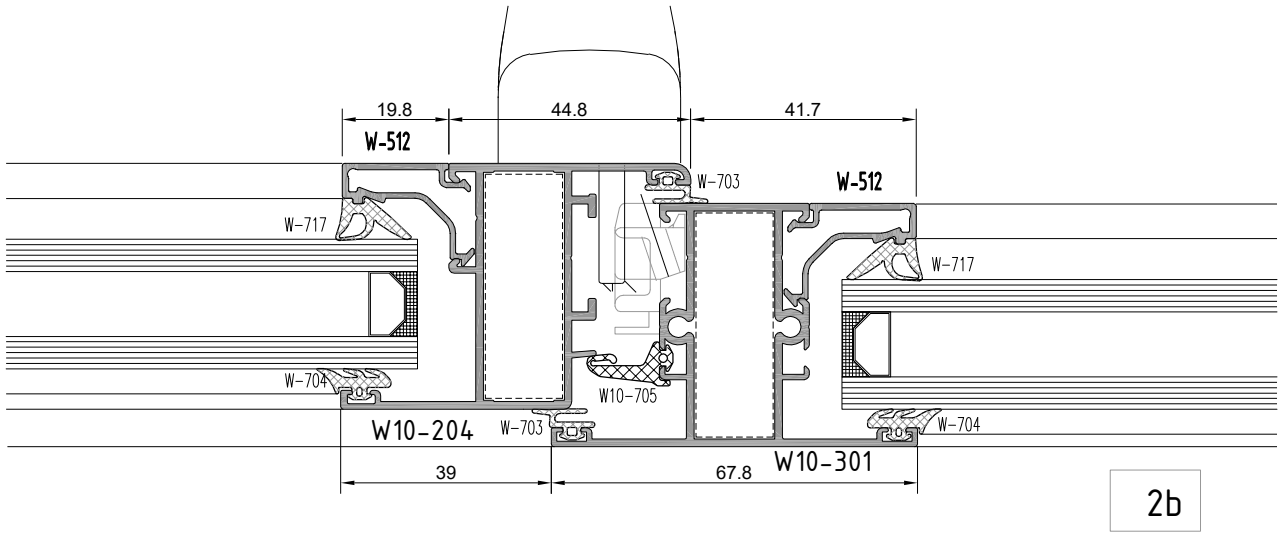
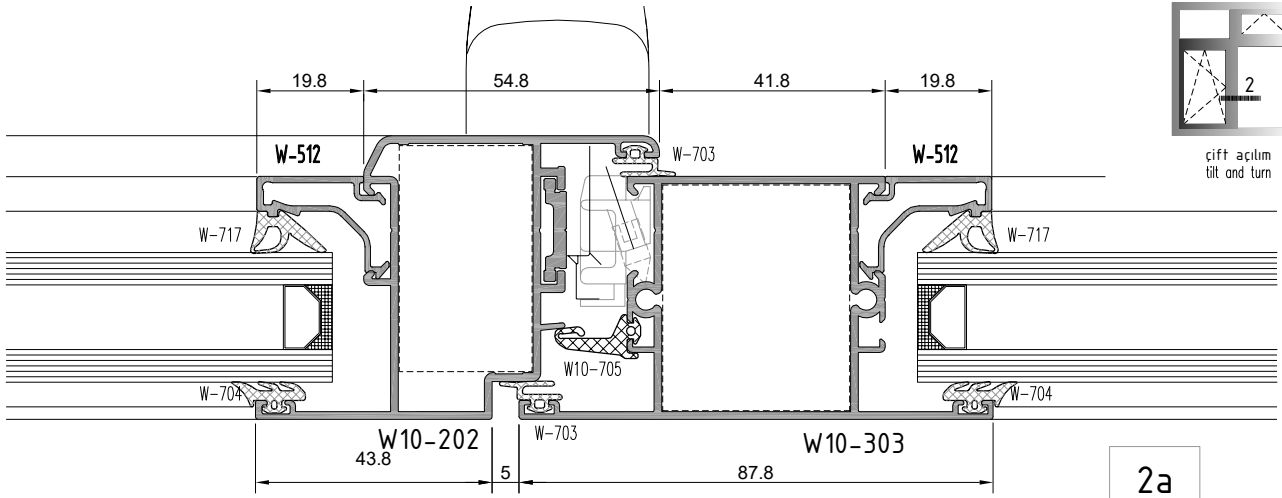

W10
W 45-1.4 YALITIMSIZ SERİ PROFİLLERİ
W45-1.4 NONINSULATED SERIES

YAN BİTİM DETAYI
WALL CONNECTION DETAIL

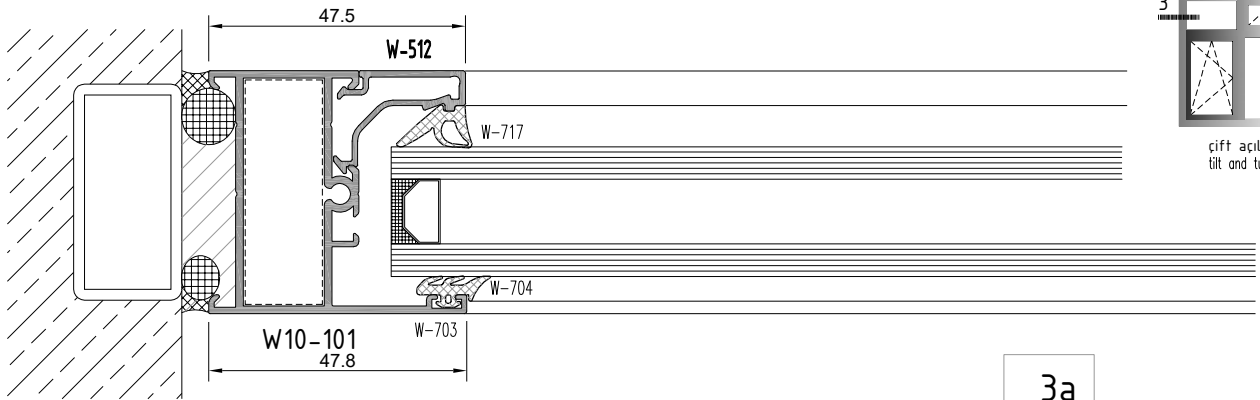

3a

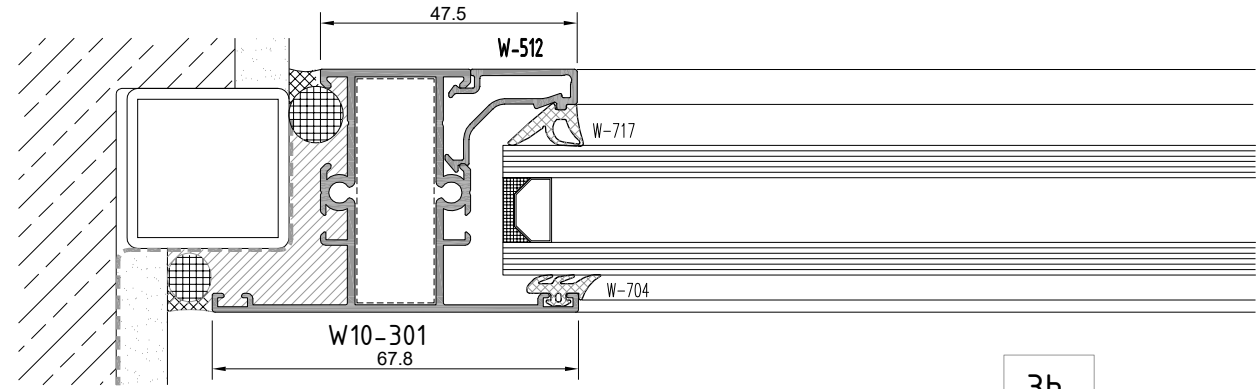

3b

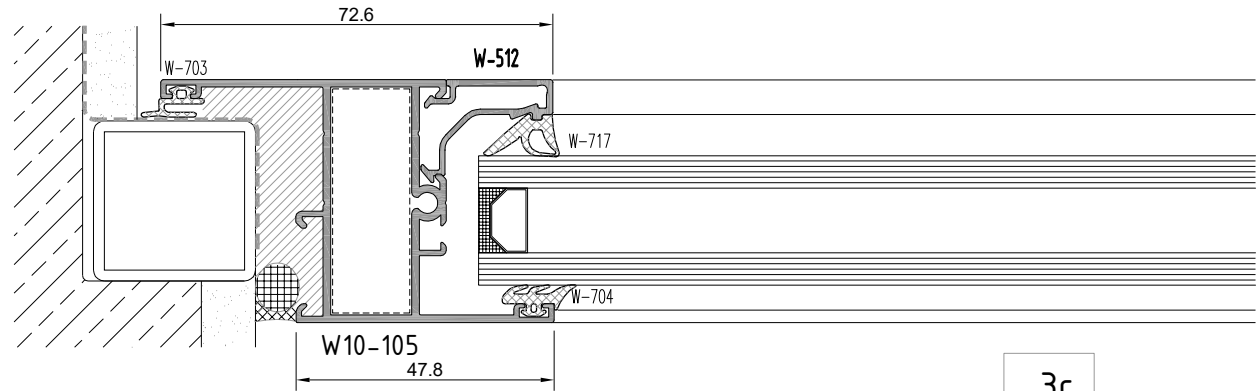

3c

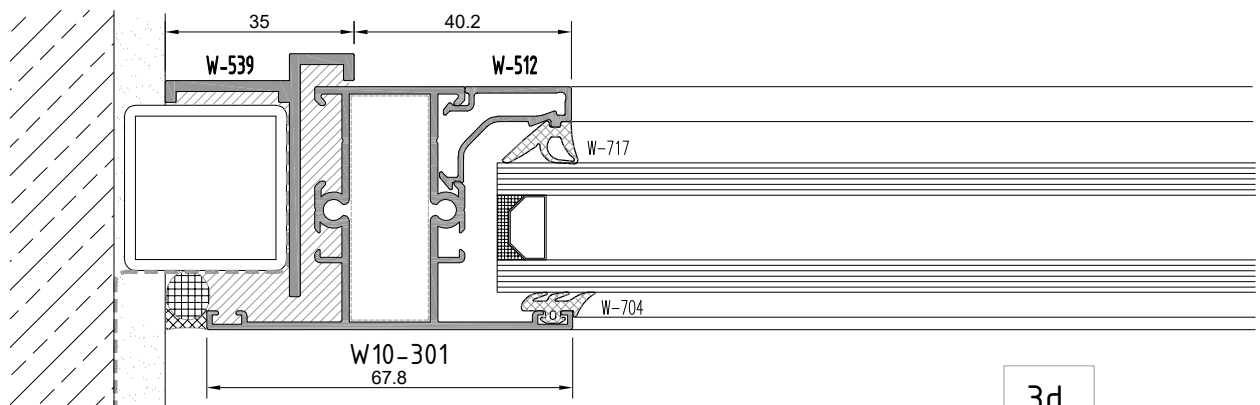

3d

not to scale

W10
W 45-1.4 YALITIMSIZ SERİ PROFİLLERİ
W45-1.4 NONINSULATED SERIES

ÜST BİTİM DETAYI
TOP EDGE - DETAIL

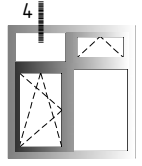

çift açılım
tilt and turn

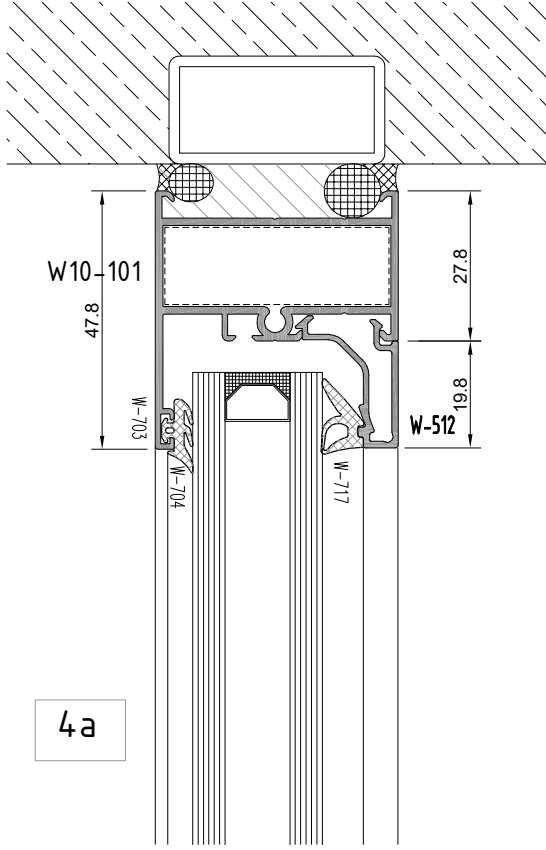

4a

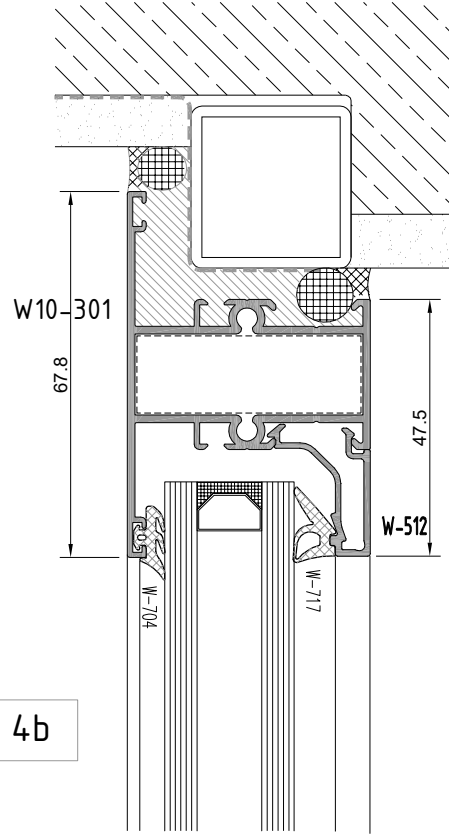

4b

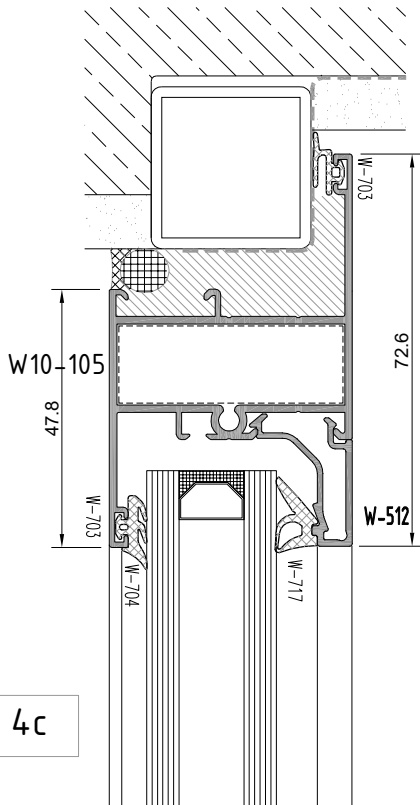

4c

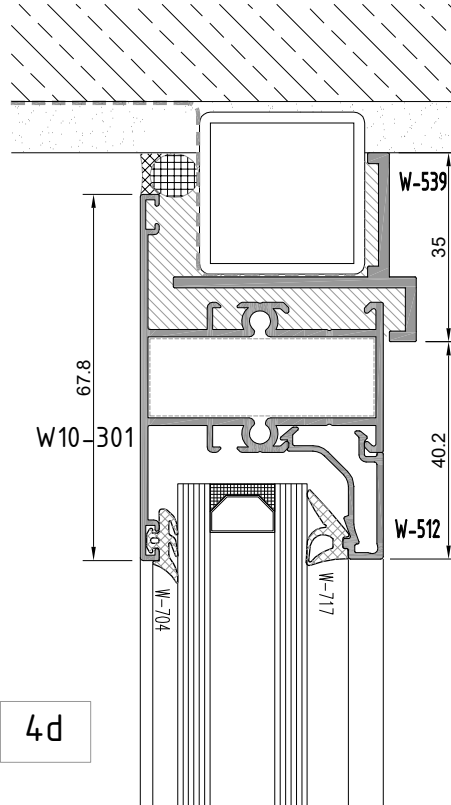

4d

not to scale

W10
W 45-1.4 YALITIMSIZ SERİ PROFİLLERİ
 W45-1.4 NONINSULATED SERIES

ORTA KAYIT DETAYI
 MULLION DETAIL

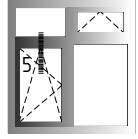
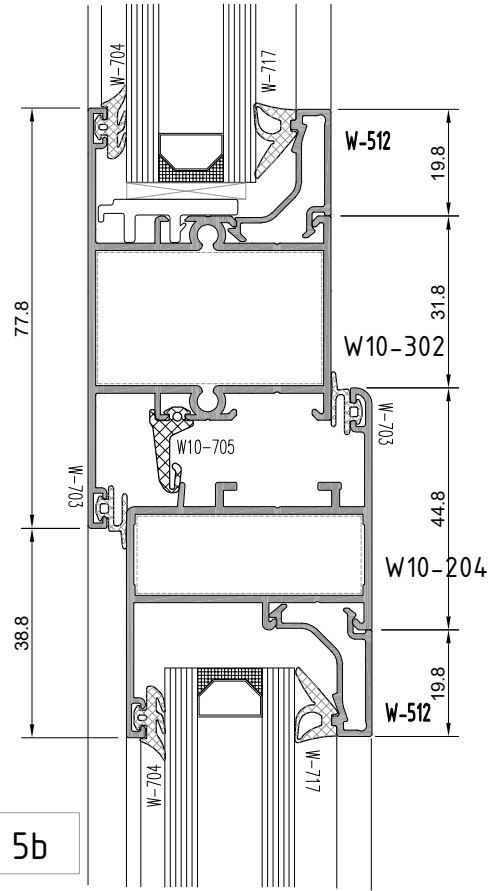
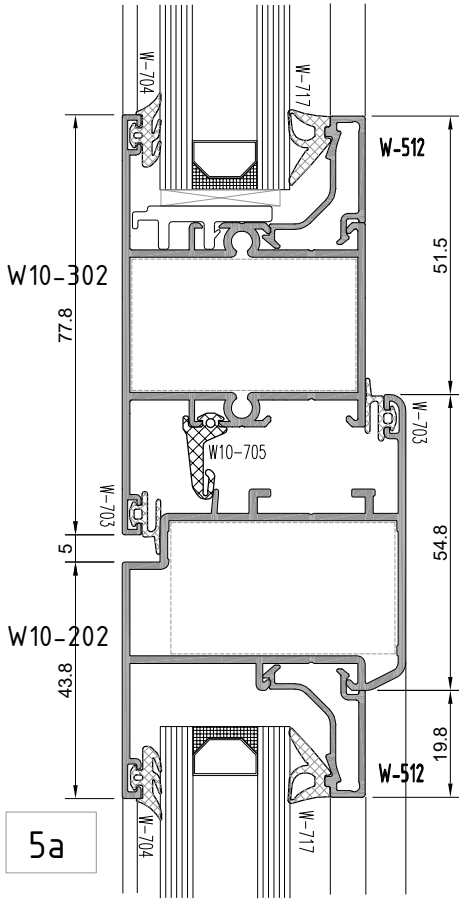

çift açılım
 tilt and turn

5b

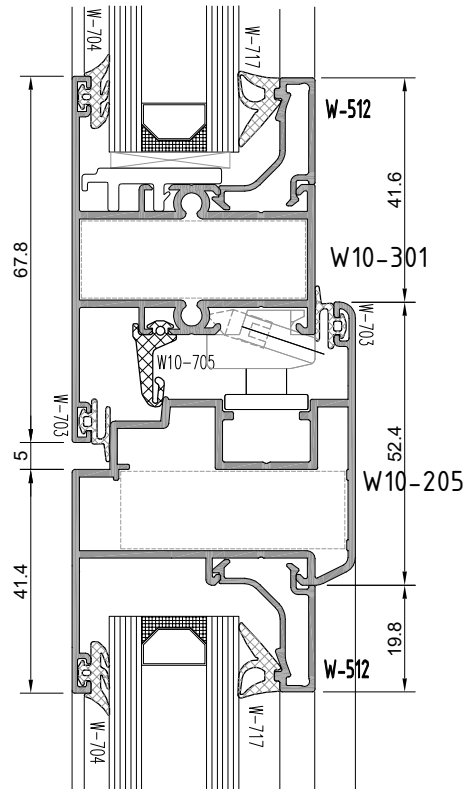

5c

W10
W 45-1.4 YALITIMSIZ SERİ PROFİLLERİ
W45-1.4 NONINSULATED SERIES

ALT BİTİM DETAYI
BOTTOM EDGE - DETAIL

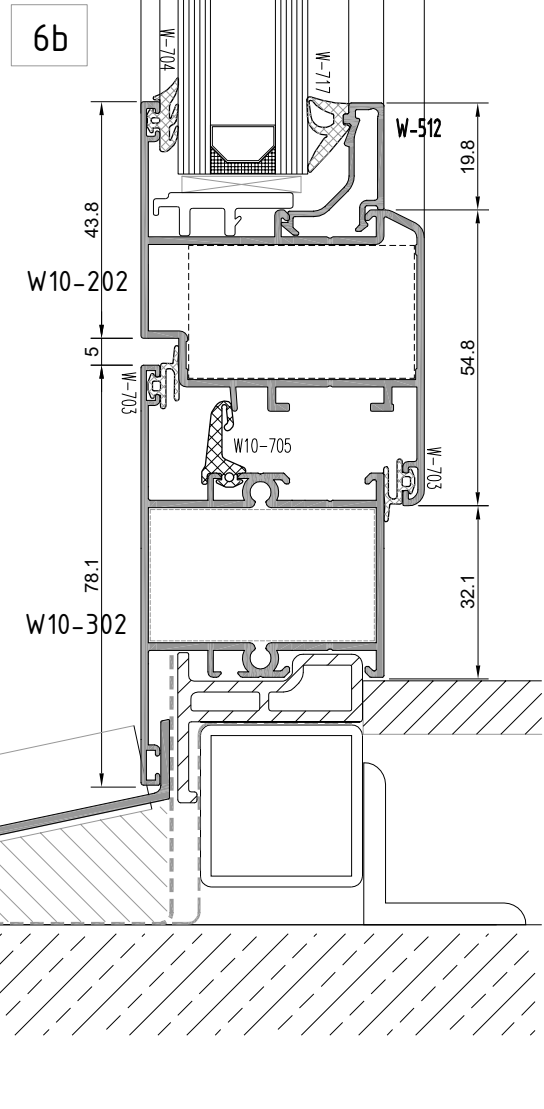
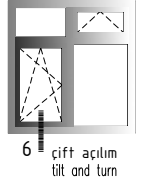
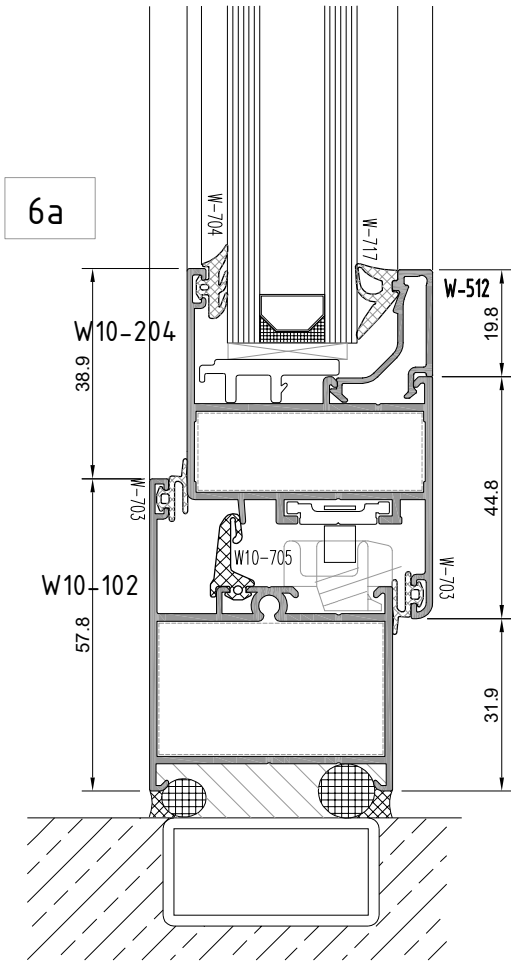

not to scale

W10
W 45-1.4 YALITIMSIZ SERİ PROFİLLERİ
W45-1.4 NONINSULATED SERIES

KÖŞE DETAYI
CORNER DETAIL

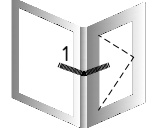

köşe dönüşü
corner turn

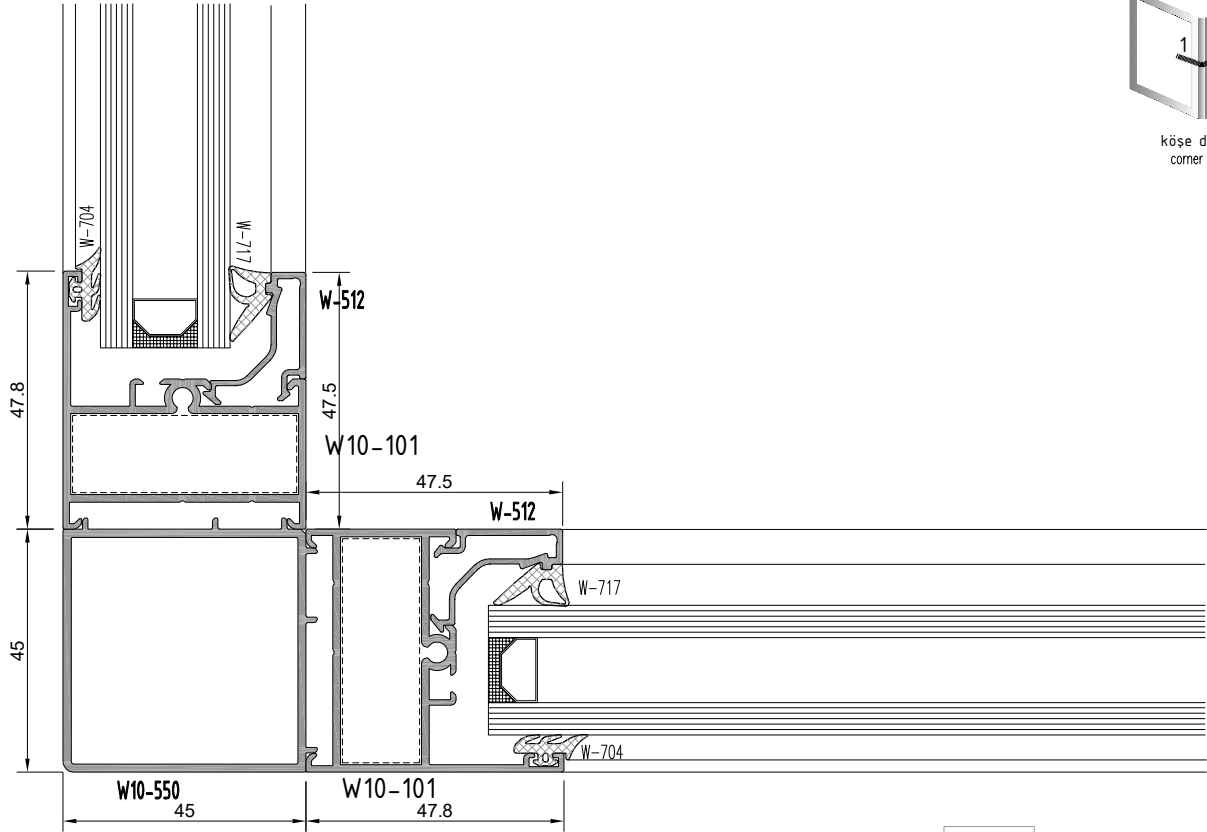

1a

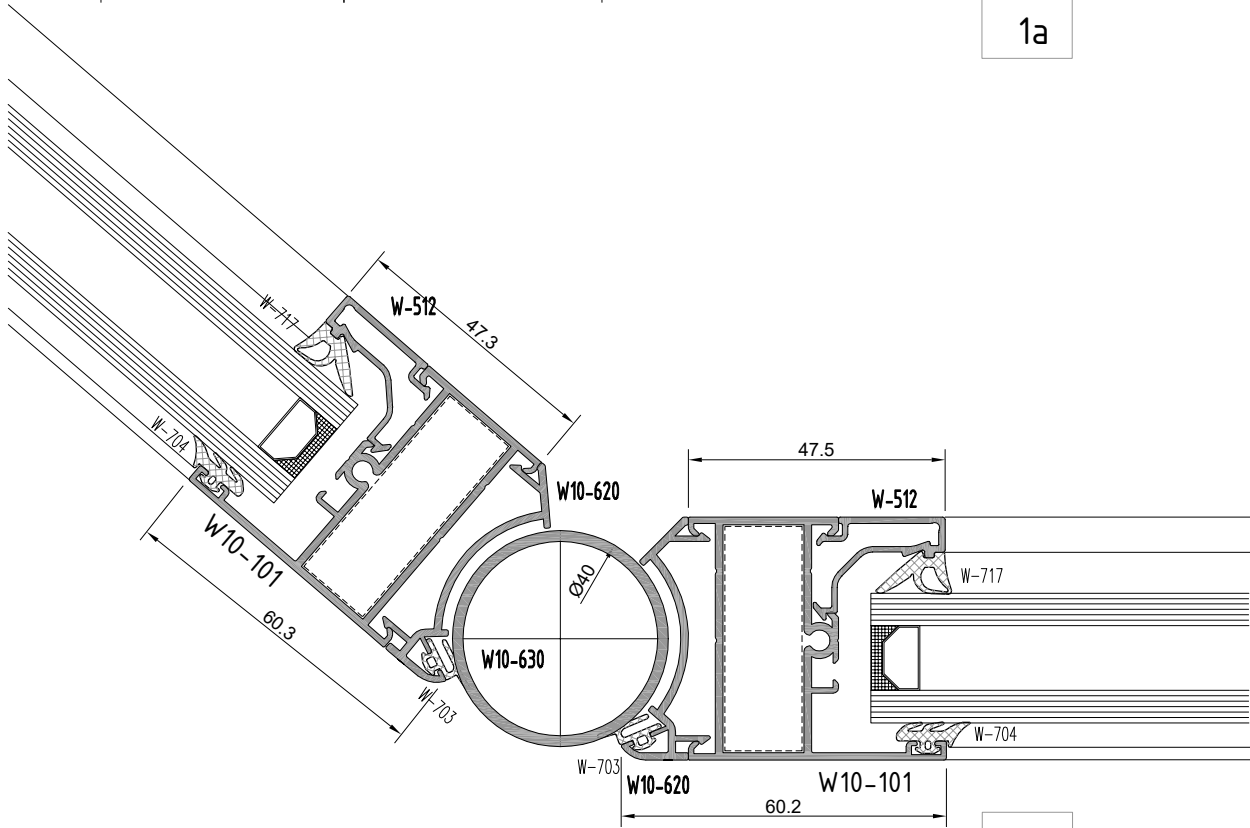

1b

not to scale

W10
W 45-1.4 YALITIMSIZ SERİ PROFİLLERİ
W45-1.4 NONINSULATED SERIES

YAN BİTİM DETAYI
WALL CONNECTION DETAIL

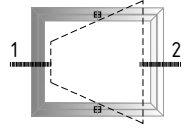

pivot açılım
pivot opening

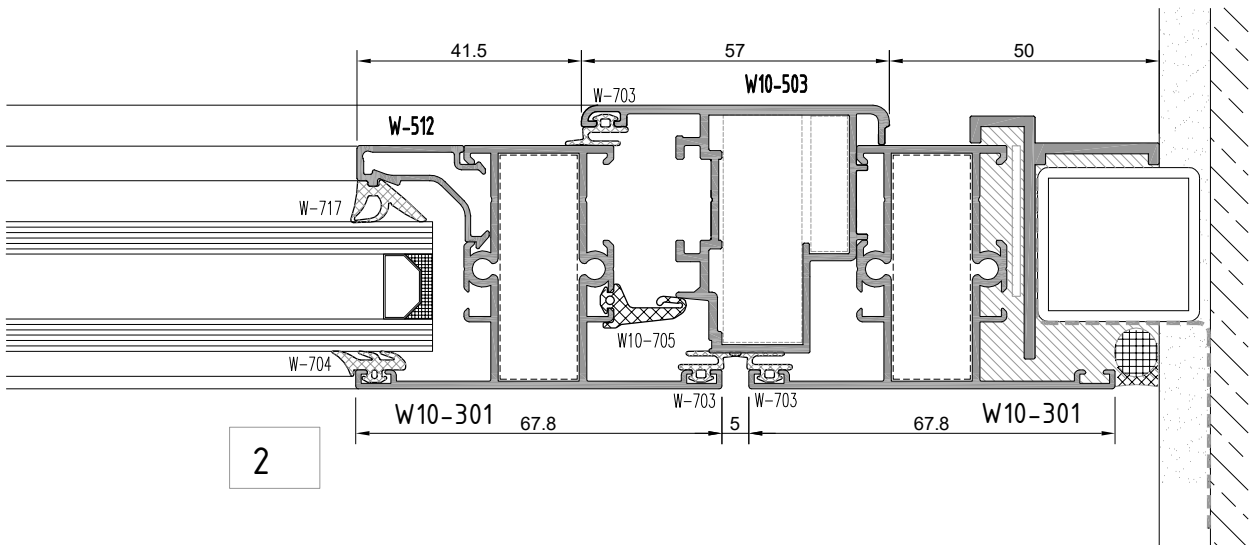
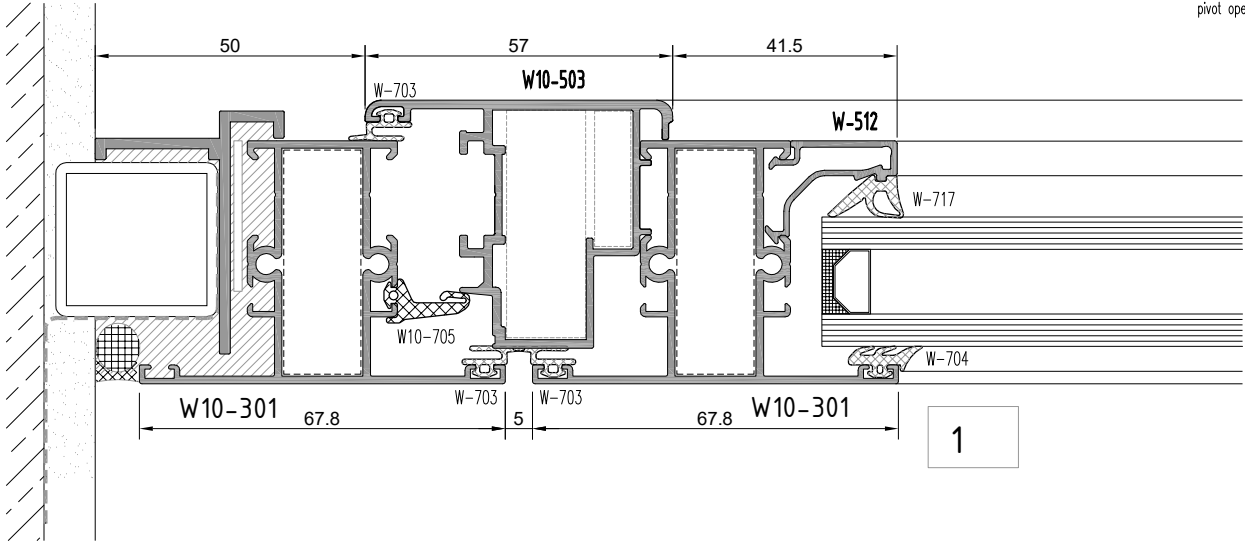

W10
W 45-1.4 YALITIMSIZ SERİ PROFİLLERİ
W45-1.4 NONINSULATED SERIES

ÜST-ALT BİTİM DETAYI
TOP EDGE-BOTTOM EDGE DETAIL

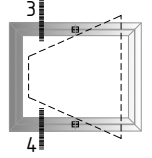

pivot açılım
pivot opening

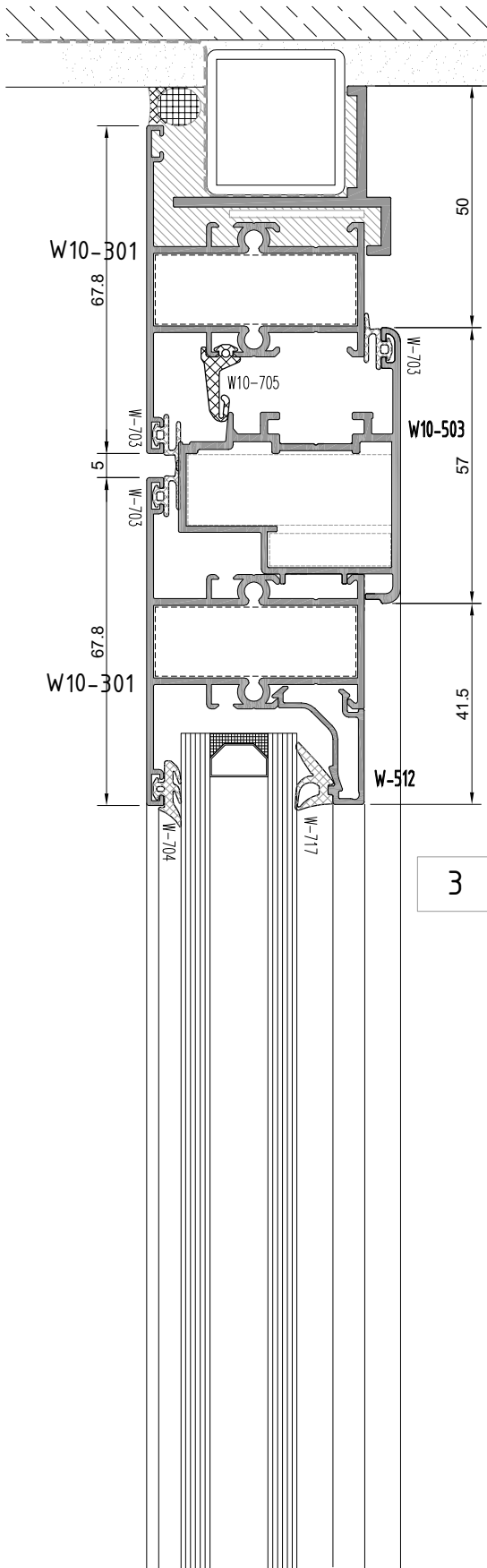

3

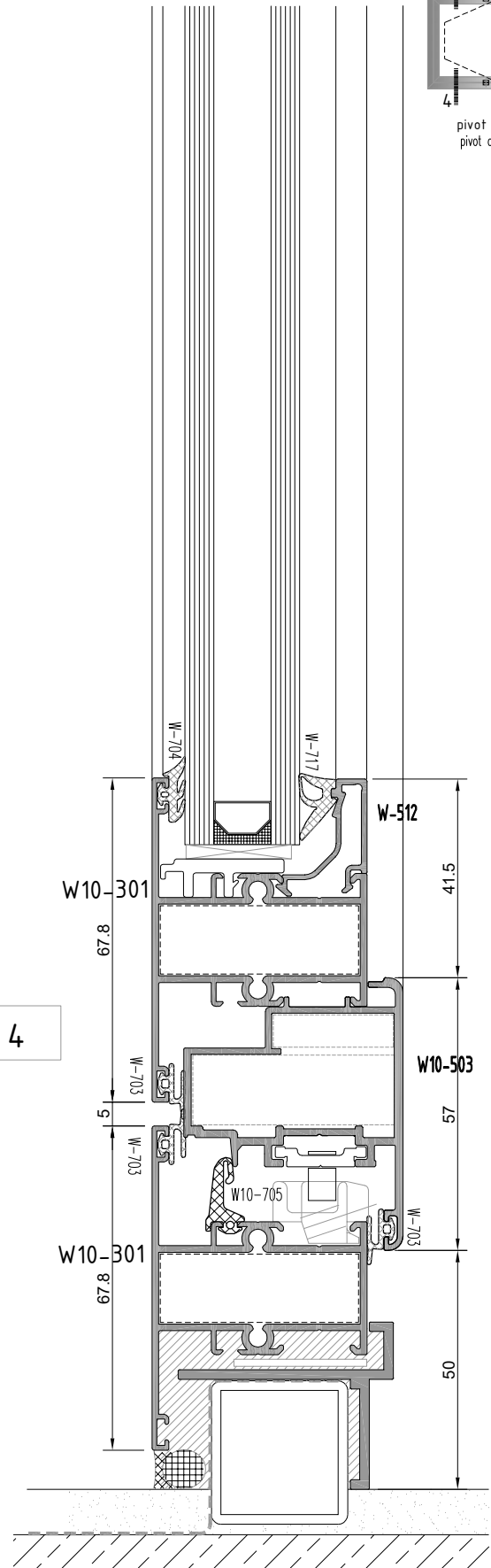

4

not to scale

W10

W 45-1.4 YALITIMSIZ SERİ PROFİLLERİ

W45-1.4 NONINSULATED SERIES

ÜST-ALT BİTİM DETAYI
TOP EDGE-BOTTOM EDGE DETAIL

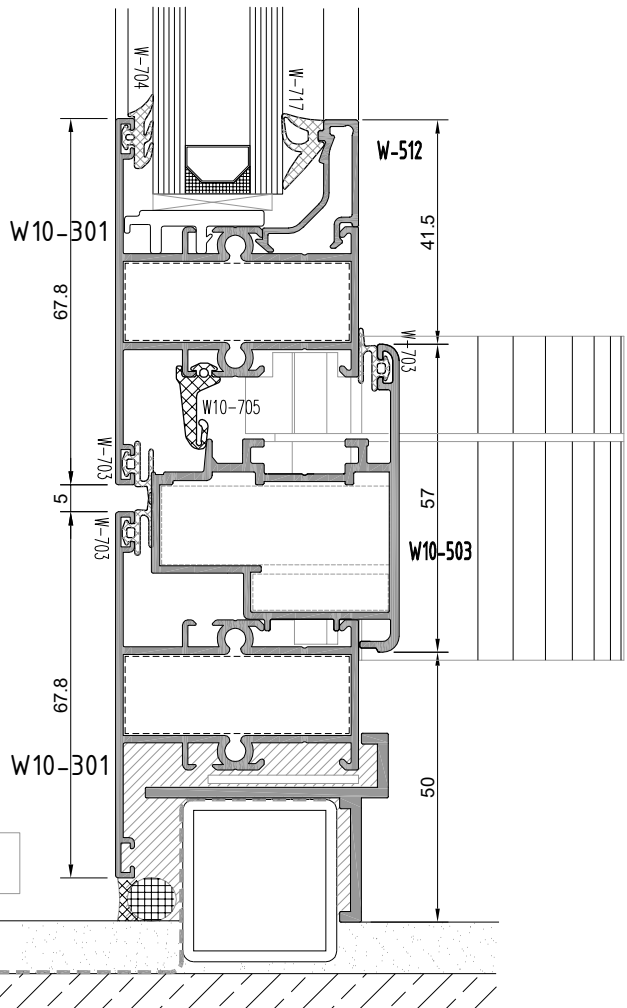
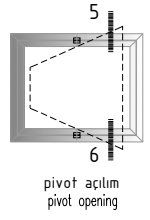
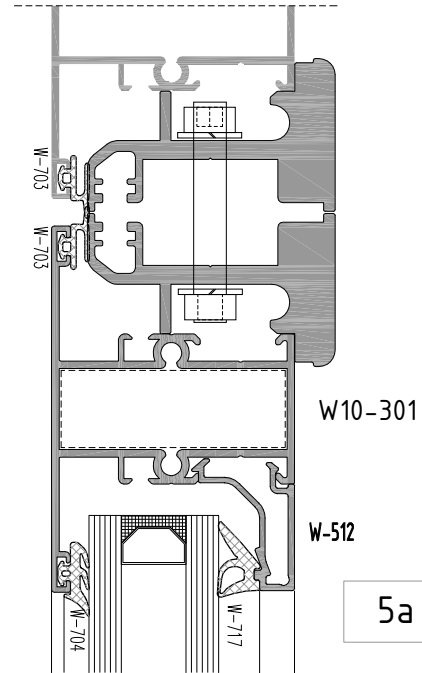
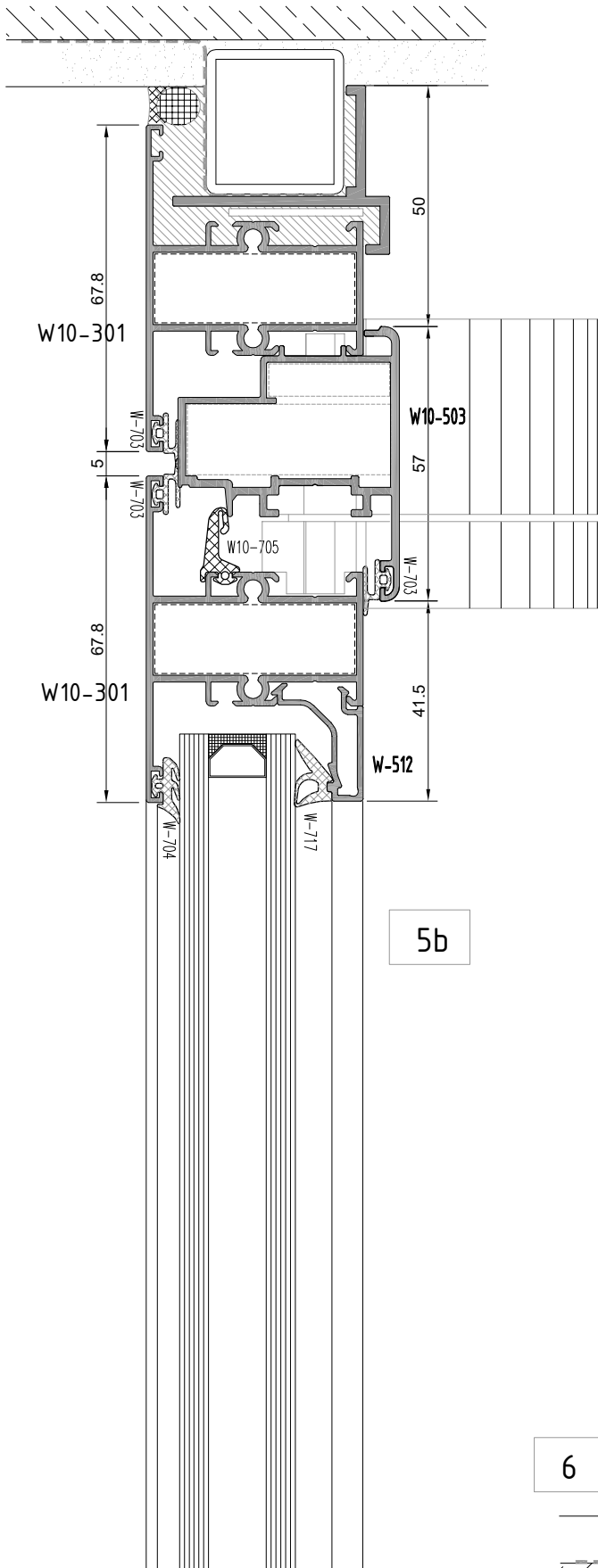

not to scale

W10
W 45-1.4 YALITIMSIZ SERİ PROFİLLERİ
W45-1.4 NONINSULATED SERIES

YAN BİTİM-KANAT BİRLEŞİM DETAYI
WALL CONNECTION-CASEMENT JOINING DETAIL

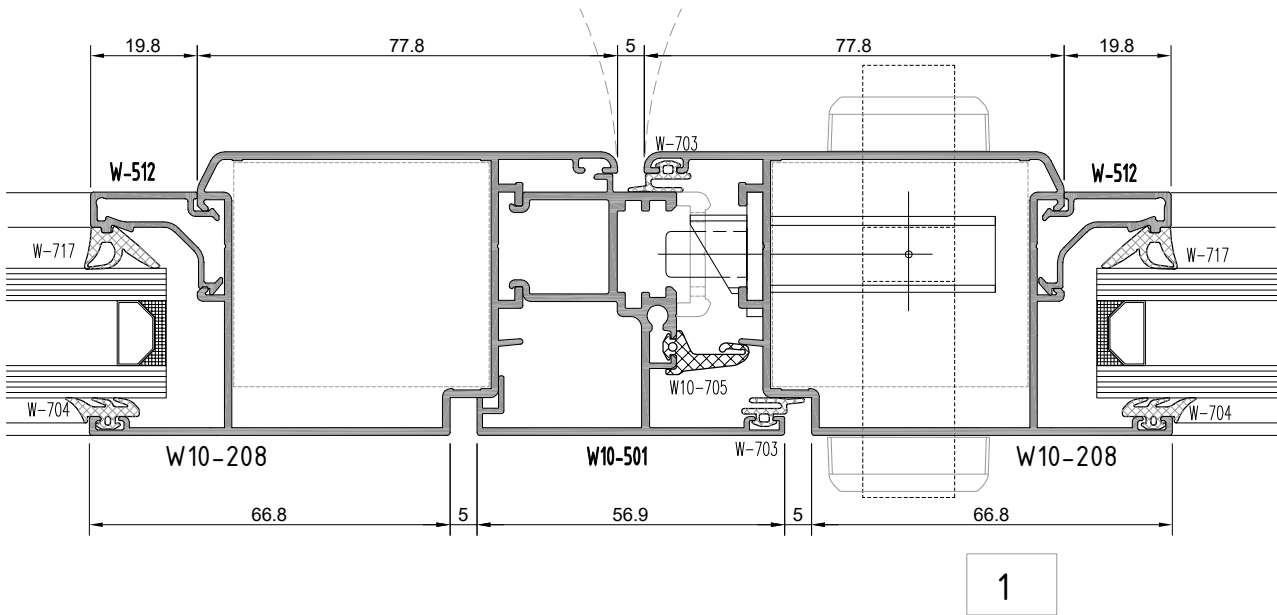
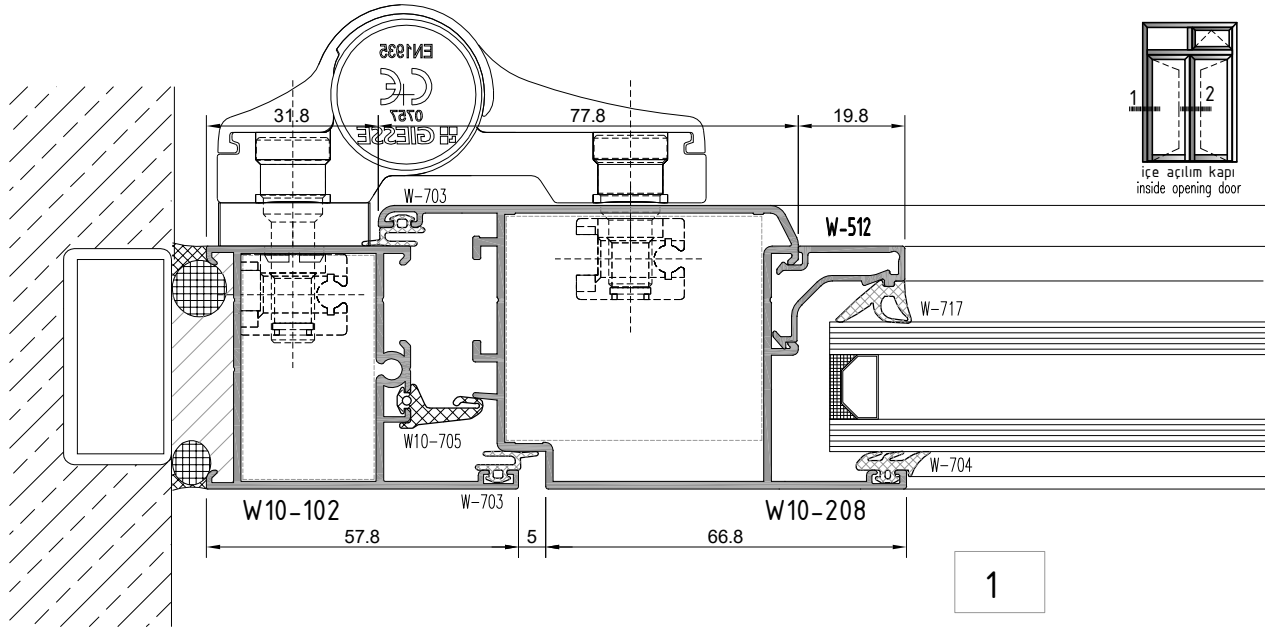

W10
W 45-1.4 YALITIMSIZ SERİ PROFİLLERİ
W45-1.4 NONINSULATED SERIES

ÜST BİTİM-ORTA KAYIT DETAYI
TOP EDGE-MULLION DETAIL

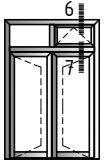

içe açılım kapı
inside opening door

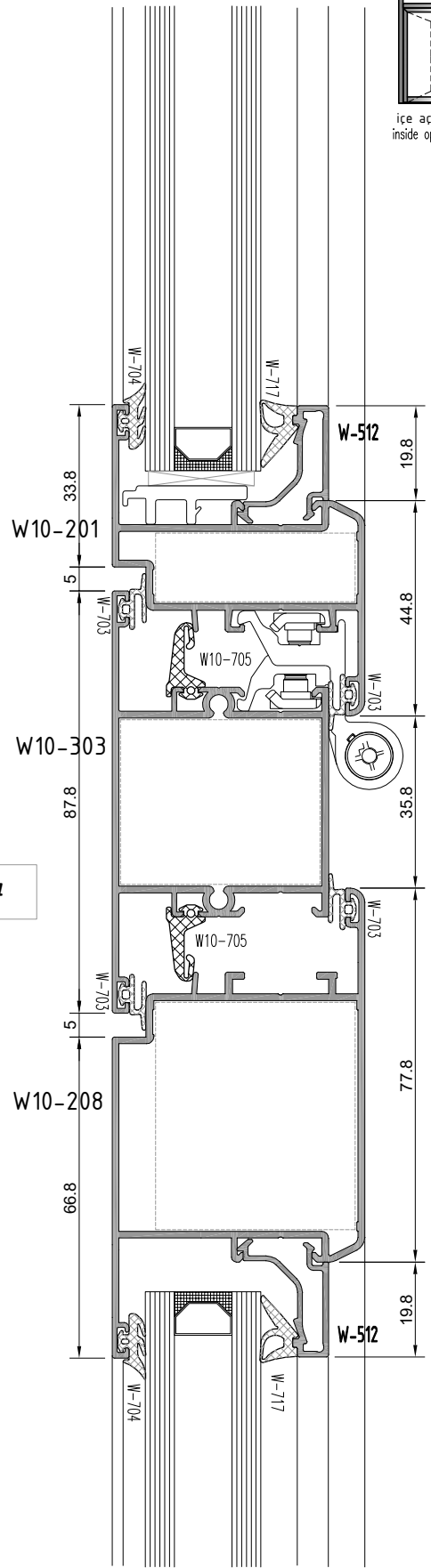
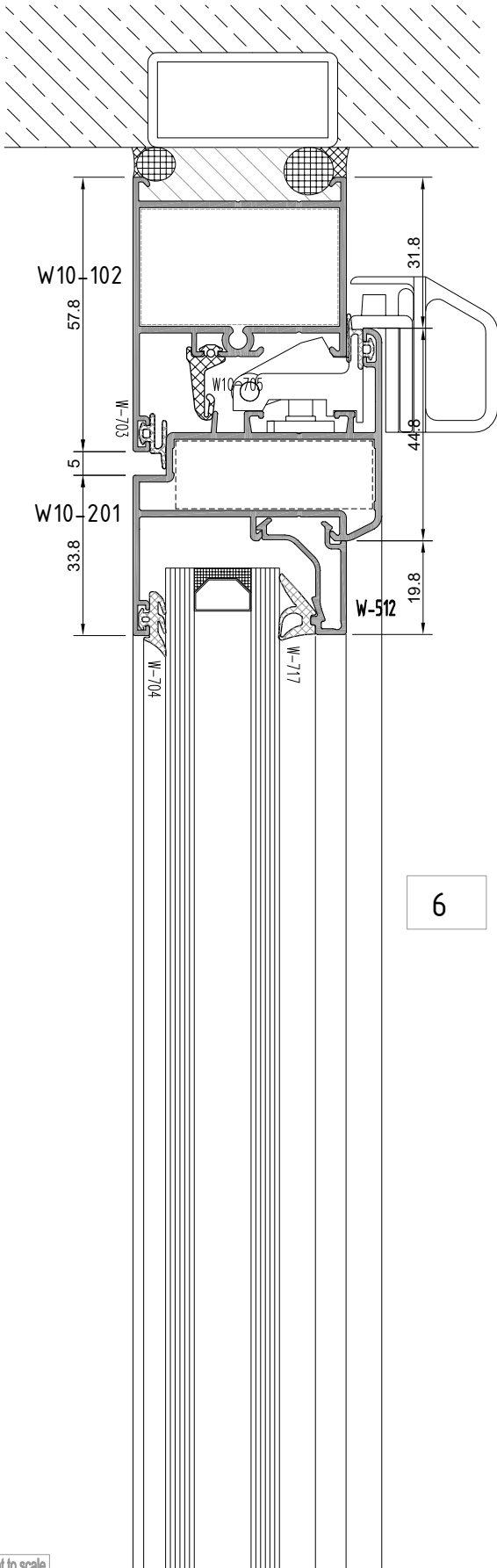

not to scale

W10

W 45-1.4 YALITIMSIZ SERİ PROFİLLERİ

W45-1.4 NONINSULATED SERIES

ALT BİTİM DETAYI
BOTTOM EDGE - DETAIL

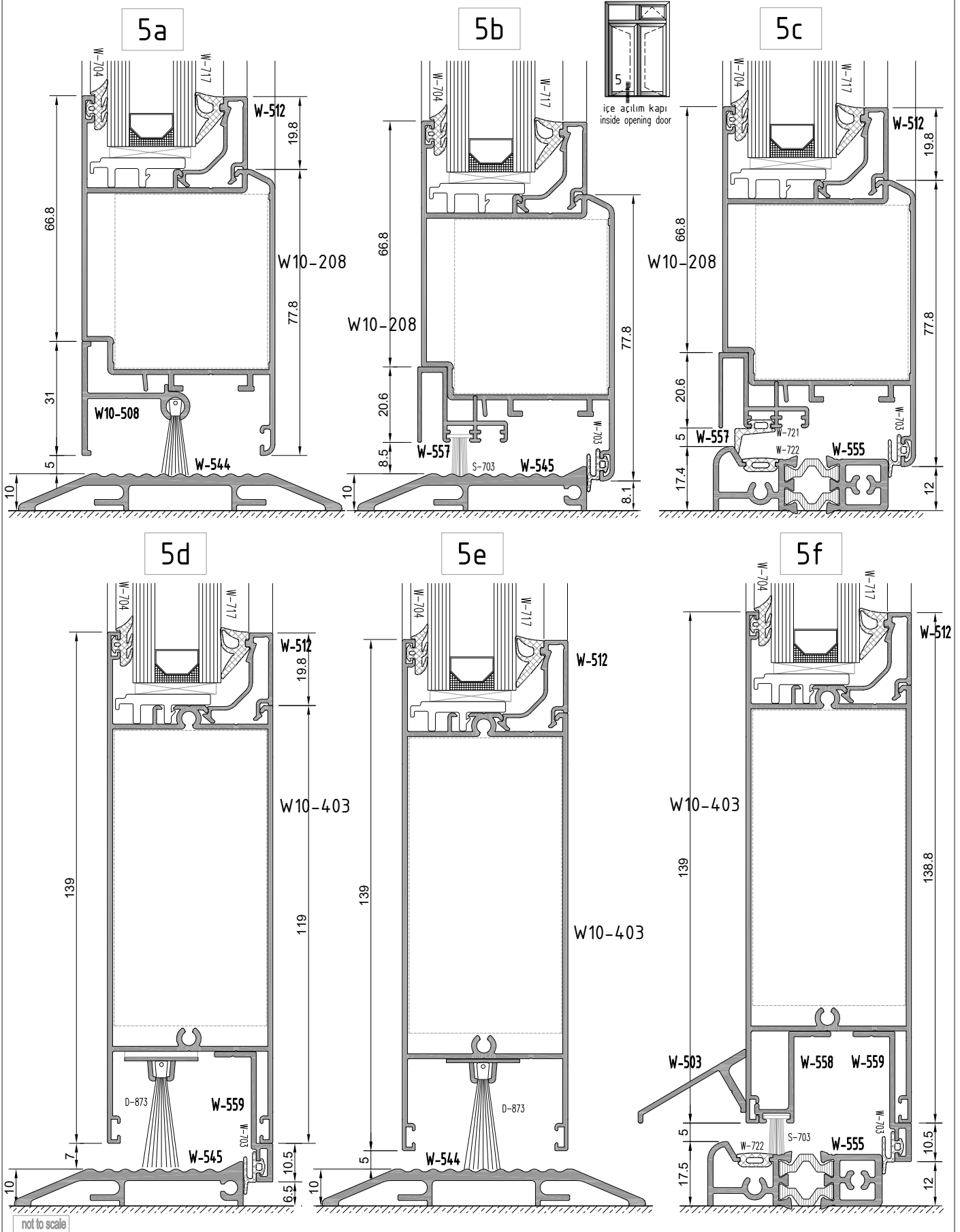

W10

W 45-1.4 YALITIMSIZ SERİ PROFİLLERİ

W45-1.4 NONINSULATED SERIES

YAN BİTİM-KANAT BİRLEŞİM DETAYI
WALL CONNECTION-CASEMENT JOINING DETAIL

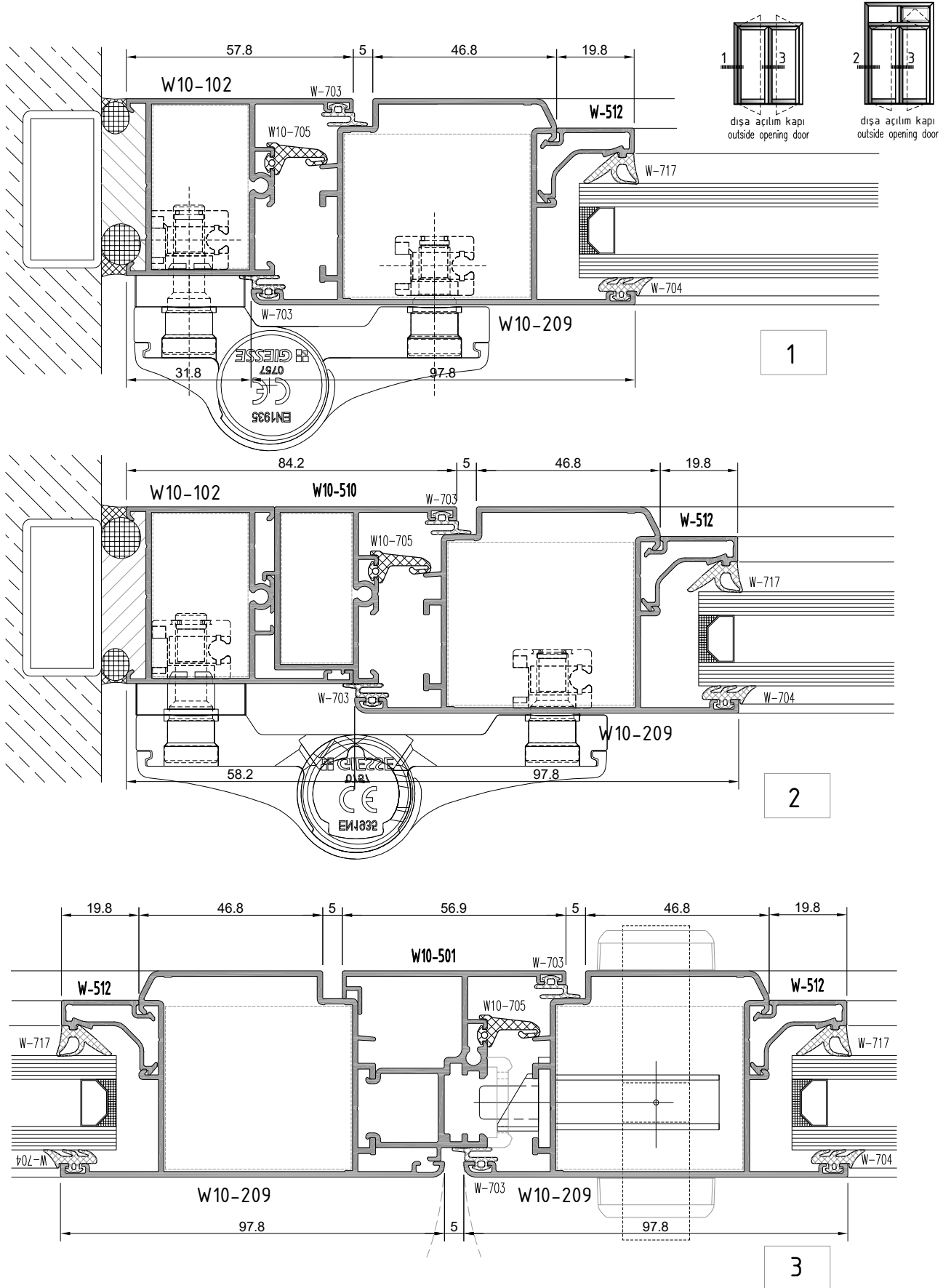

not to scale

W10
W 45-1.4 YALITIMSIZ SERİ PROFİLLERİ
 W45-1.4 NONINSULATED SERIES

ÜST BİTİM-ORTA KAYIT DETAYI
 TOP EDGE-MULLION DETAIL

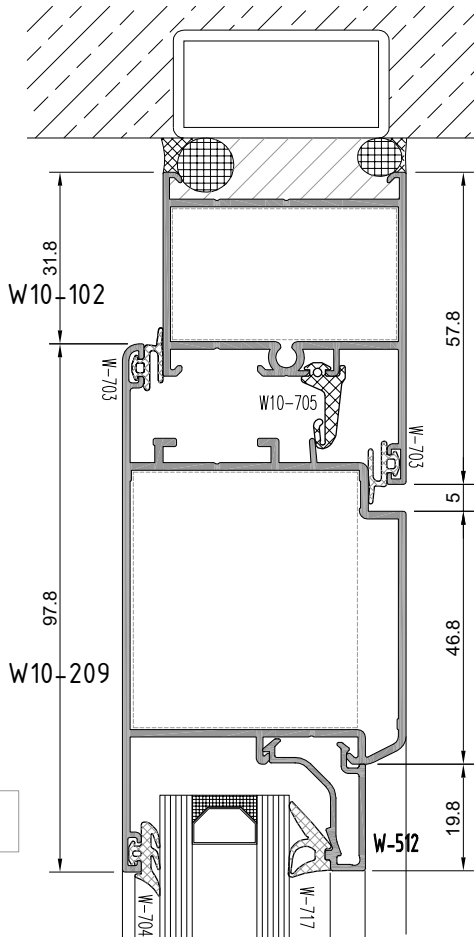
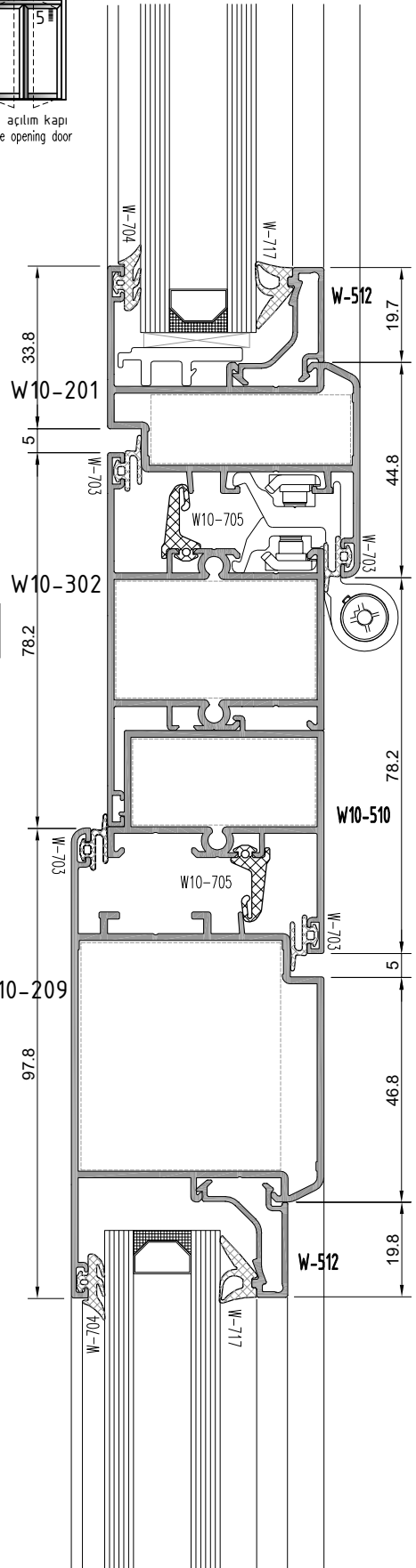
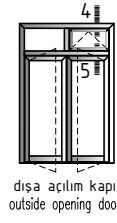
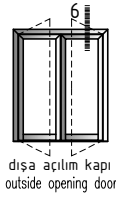
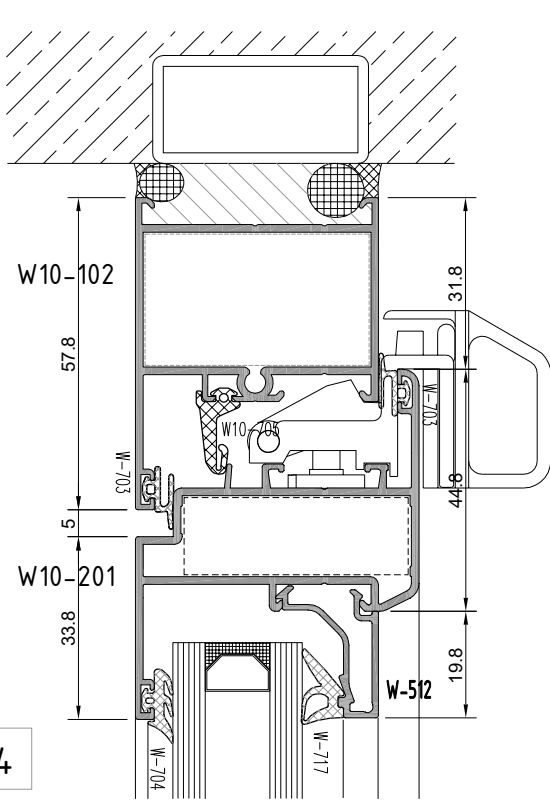

not to scale

W10
W 45-1.4 YALITIMSIZ SERİ PROFİLLERİ
 W45-1.4 NONINSULATED SERIES

ALT BİTİM DETAYI
 BOTTOM EDGE - DETAIL

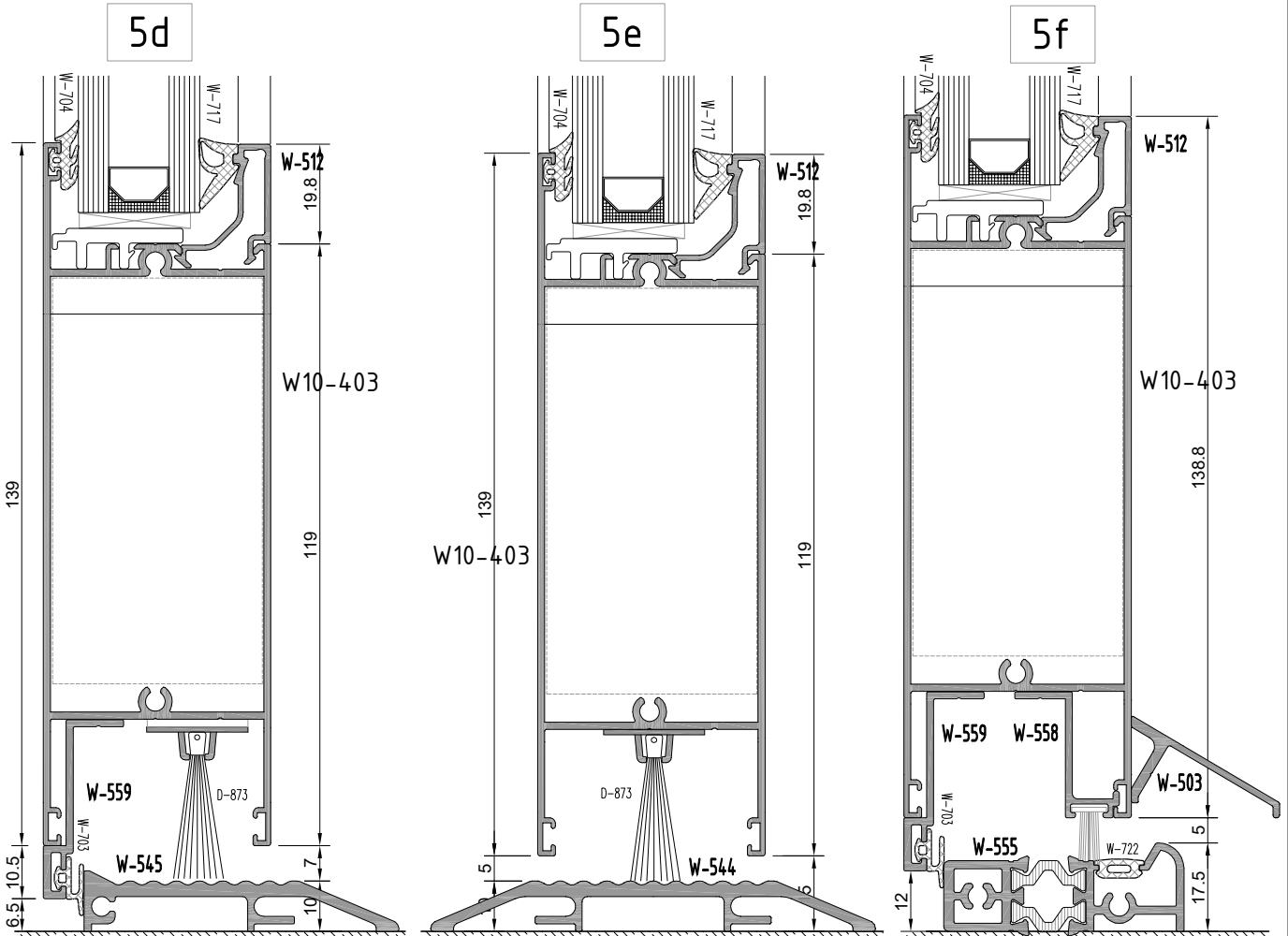
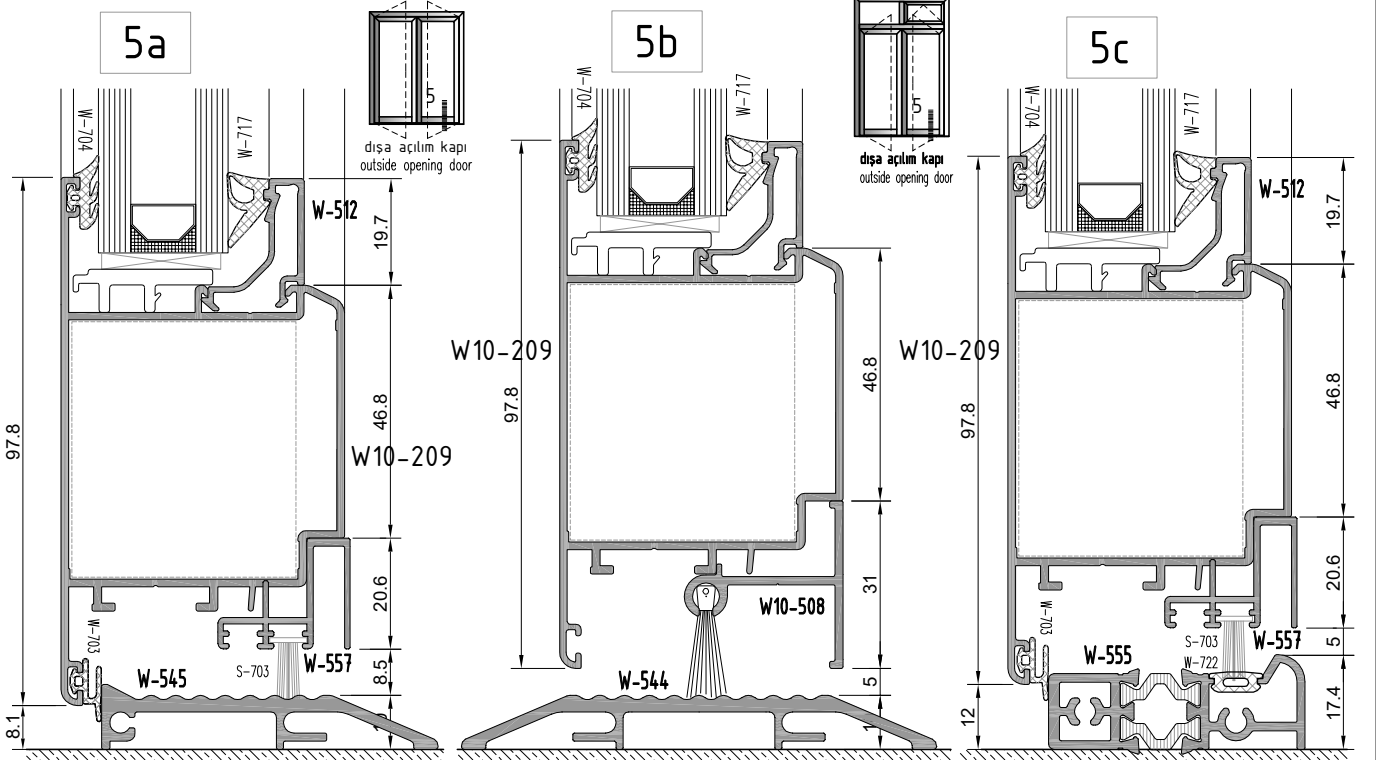

not to scale

W10
W 45-1.4 YALITIMSIZ SERİ PROFİLLERİ
W45-1.4 NONINSULATED SERIES

YAN BİTİM-ORTA KAYIT DETAYI
WALL CONNECTION-MULLION DETAIL

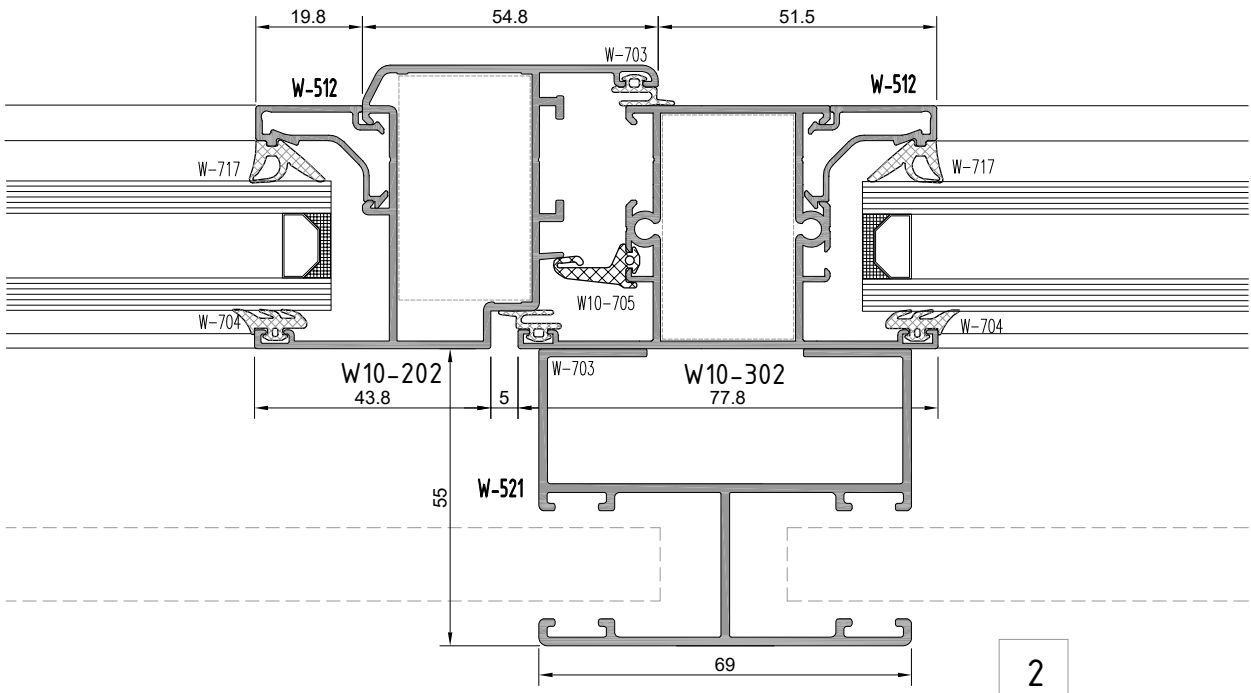
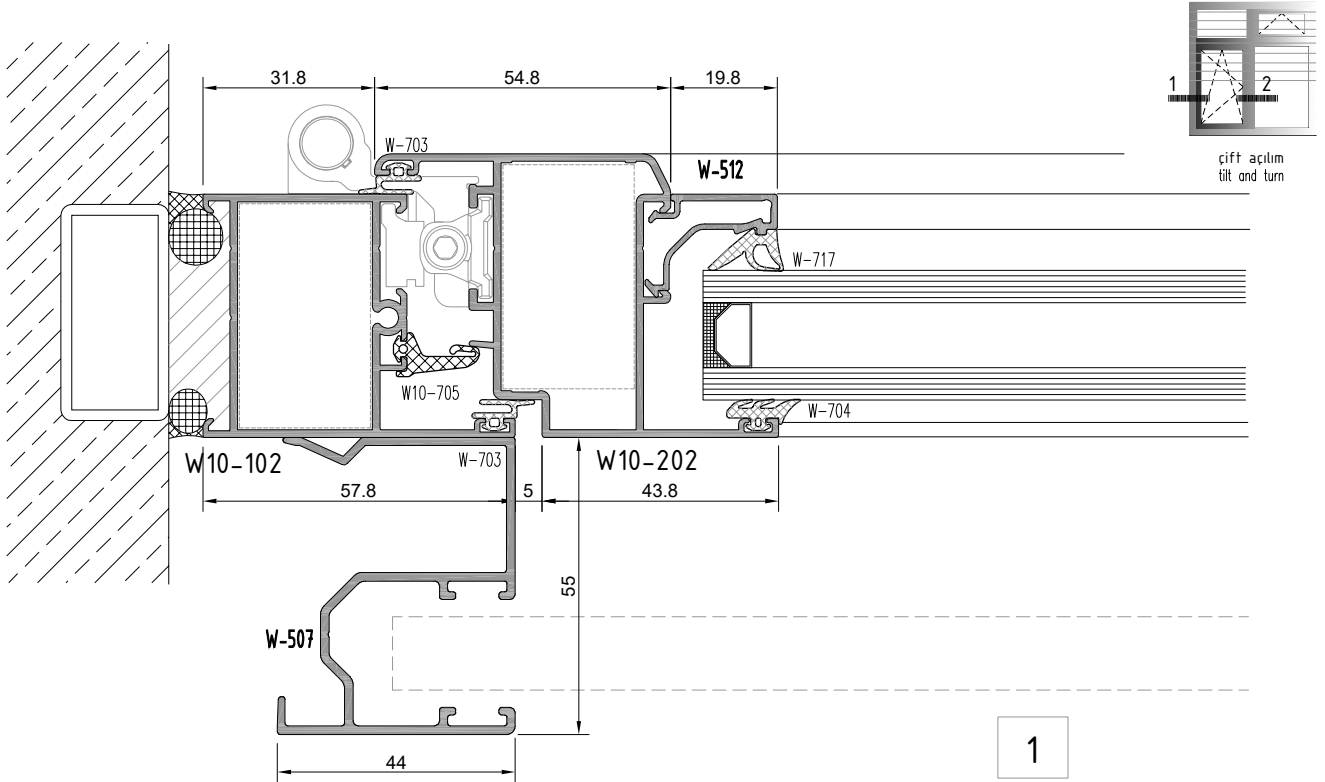

not to scale

W10
W 45-1.4 YALITIMSIZ SERİ PROFİLLERİ
W45-1.4 NONINSULATED SERIES

ÜST BİTİM DETAYI
TOP EDGE - DETAIL

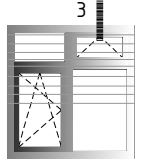

cift acilm
tilt and turn

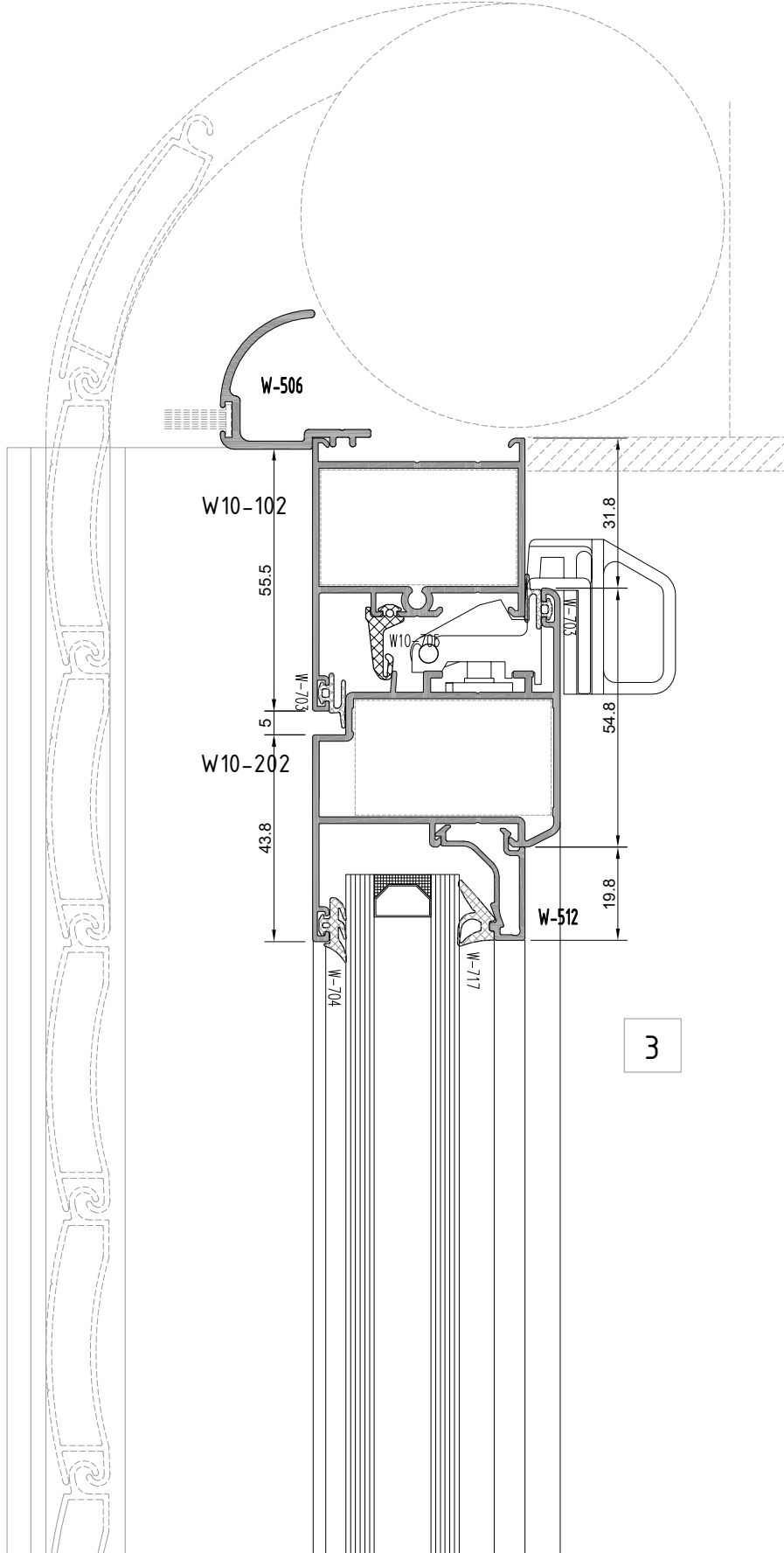

not to scale

W10
W 45-1.4 YALITIMSIZ SERİ PROFİLLERİ
W45-1.4 NONINSULATED SERIES

YAN BİTİM-ÜST-ALT BİTİM DETAYI
WALL CONNECTION-TOP, BOTTOM EDGE DETAIL

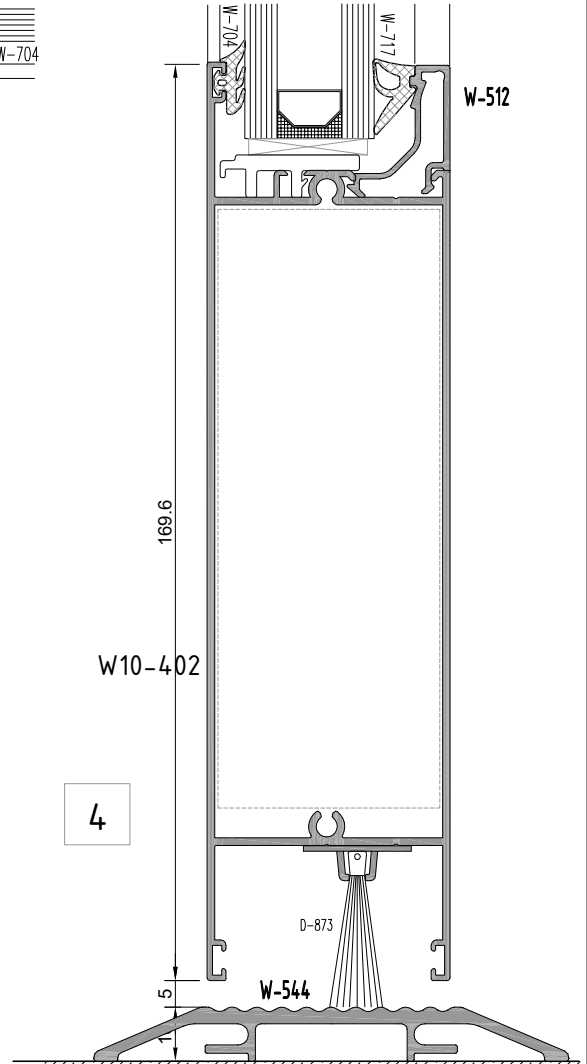
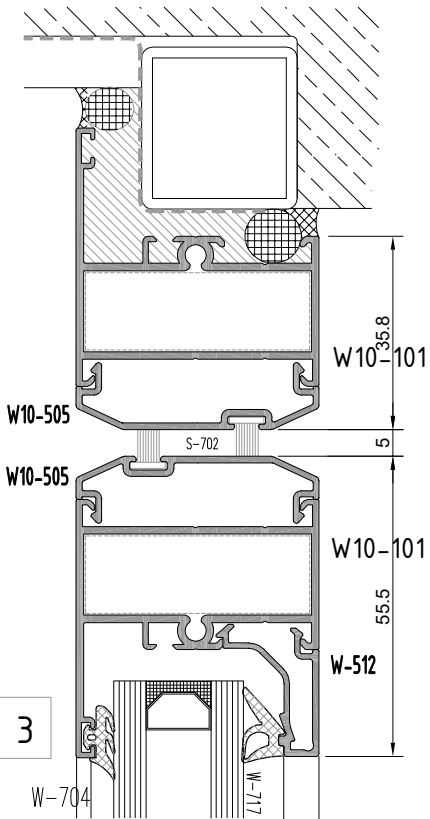
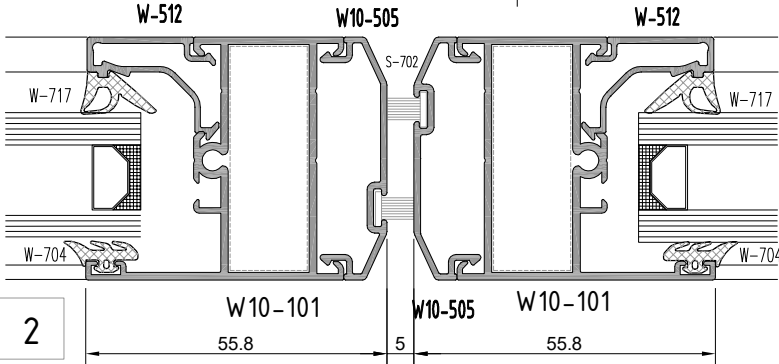
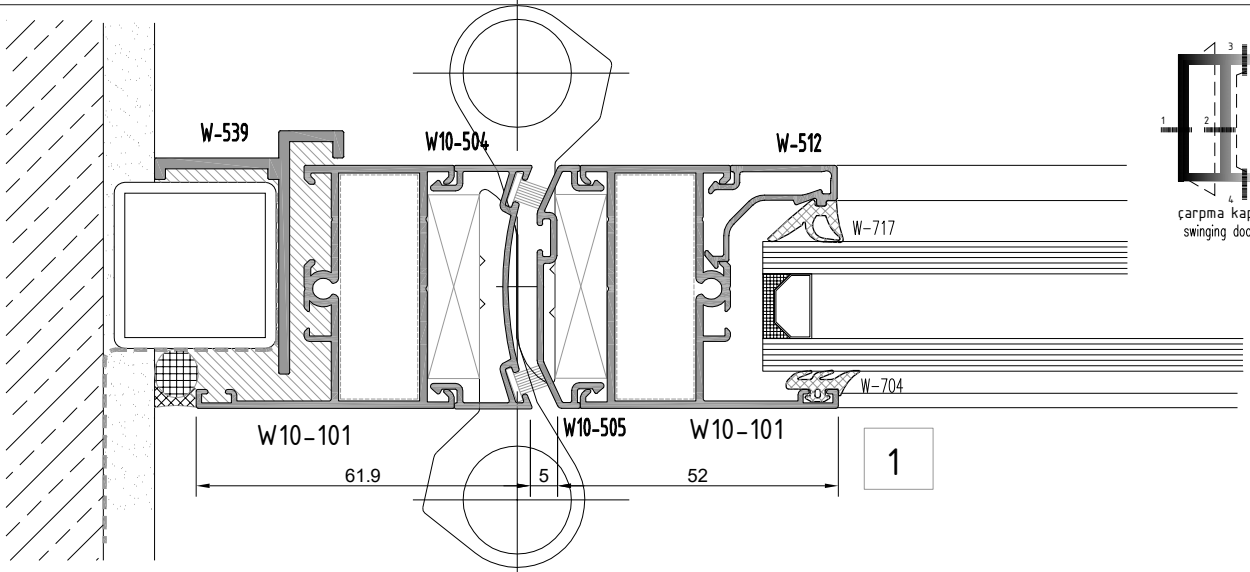

not to scale

W10
W 45-1.4 YALITIMSIZ SERİ PROFİLLERİ
W45-1.4 NONINSULATED SERIES

CEPHE BİRLEŞİM DETAYI
FACADE SYSTEM MERGE DETAIL

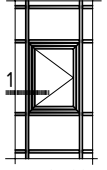

cephe içi
içe açılım pencere
inside opening casement
for facade sys.

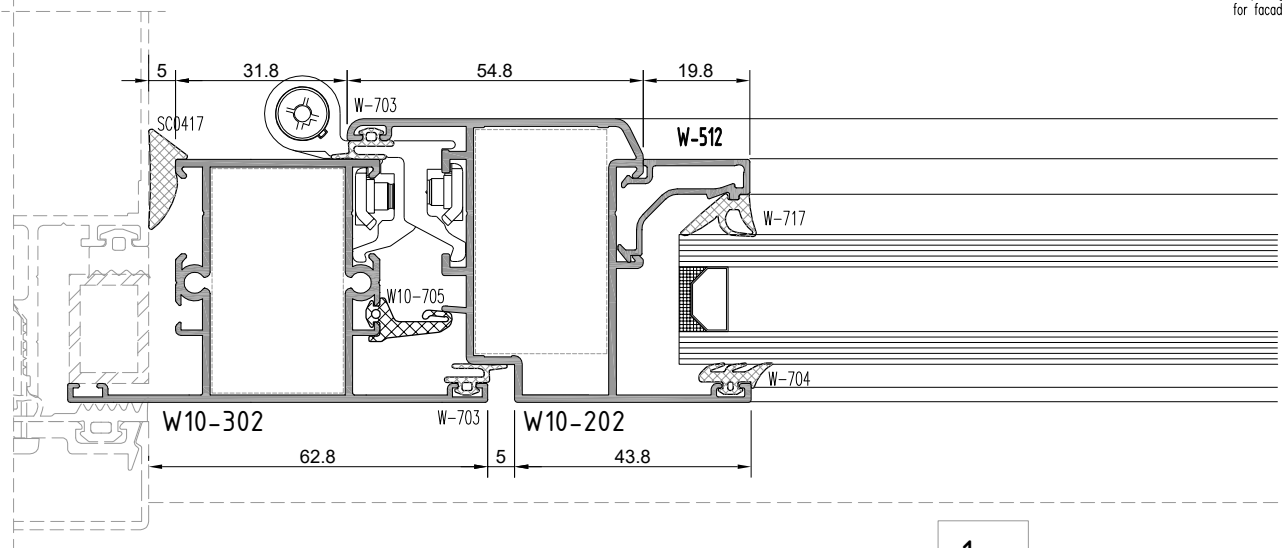

1a

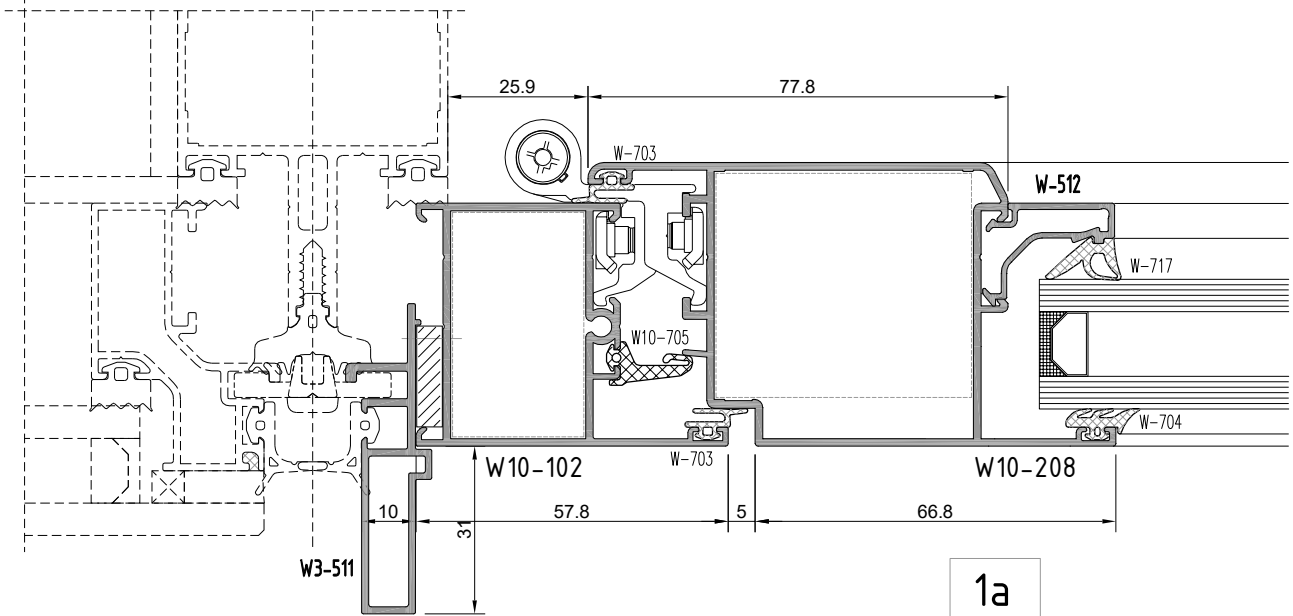

1a

not to scale

W10

W 45-1.4 YALITIMSIZ SERİ

W45-1.4 UNINSULATED SERIES

İMALAT ŞEMASI

PRODUCTION PLAN

NORMAL / VAŞİSTAS / ÇİFT AÇILIM PENCERE

NORMAL / TILT / TILT & TURN WINDOW

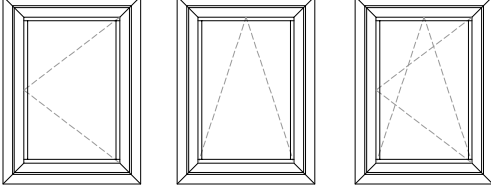

$$K1 = X + 12$$

$$K2 = Y + 12$$

$$G = B + 28$$

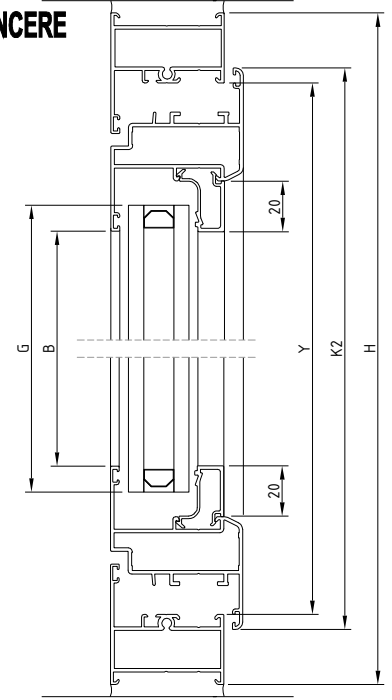
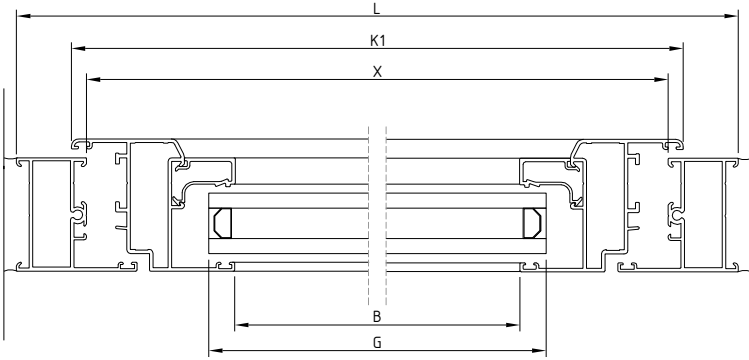

NORMAL / NORMAL VE ÇİFT AÇILIM / WOSVAGEN AÇILIM PENCERE

NORMAL / TILT & TURN END SIDE HUNG / WOSVAGEN WINDOW

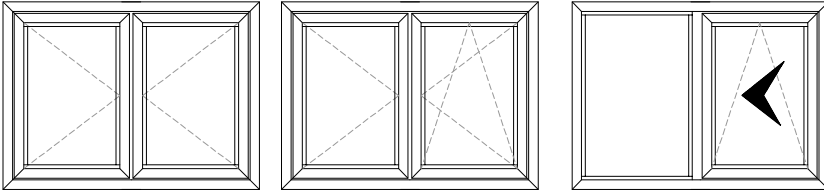

$$K = \frac{X + 12 - 5}{2}$$

$$K = Y + 12$$

$$G = B + 28$$

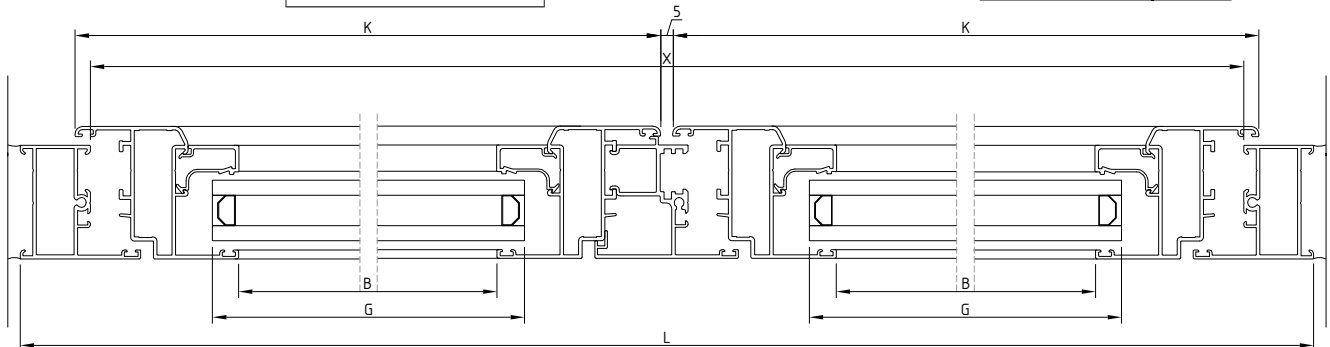
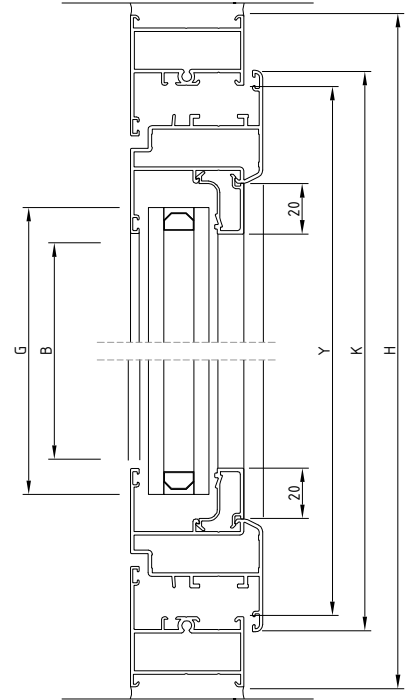

W10
W 45-1.4 YALITIMSIZ SERİ
W45-1.4 UNINSULATED SERIES

İMALAT ŞEMASI
PRODUCTION PLAN

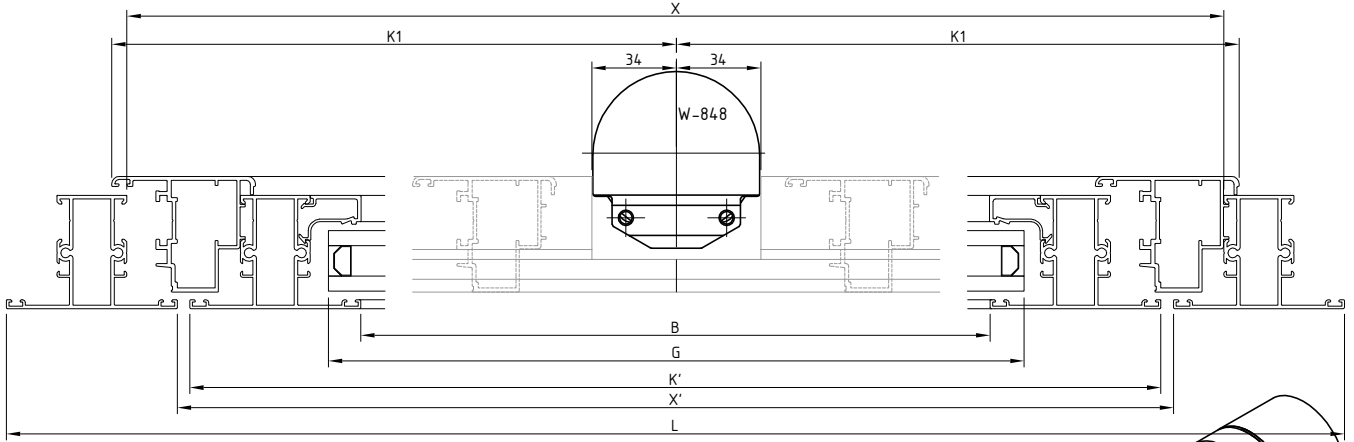

$$K1 = \frac{X - 67 + 12}{2}$$

$$K2 = Y + 12$$

$$G = B + 28$$

$$K' = X' - 10$$

$$K = Y + 6 \text{ özel işlemlı}$$

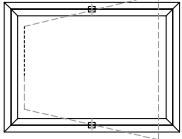
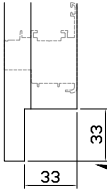

PIVOT ACILIM PENCERE
PIVOT WING OPENING WINDOW

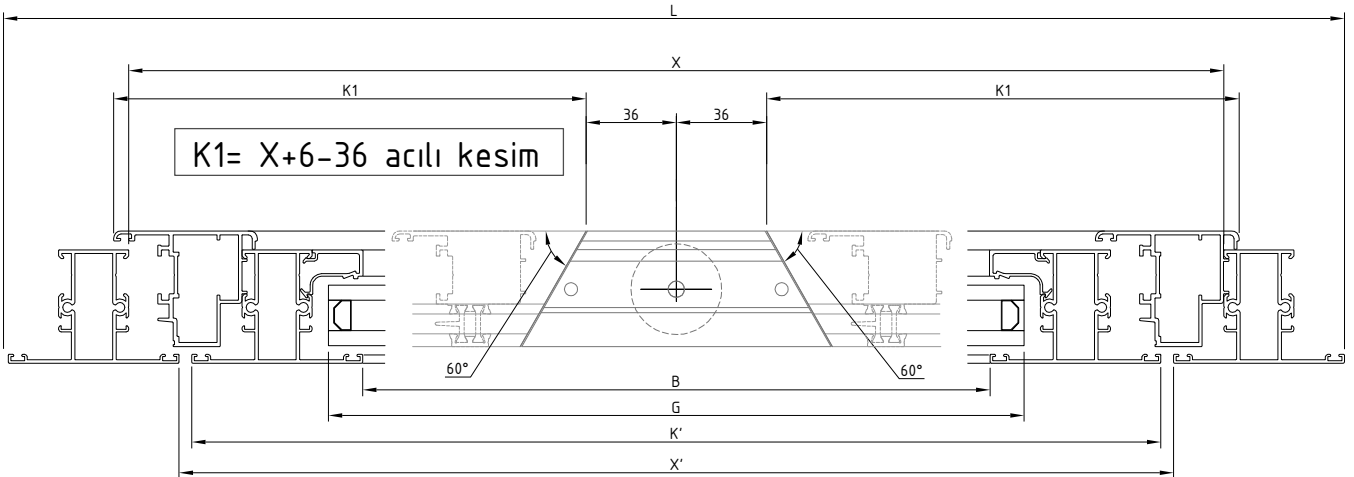
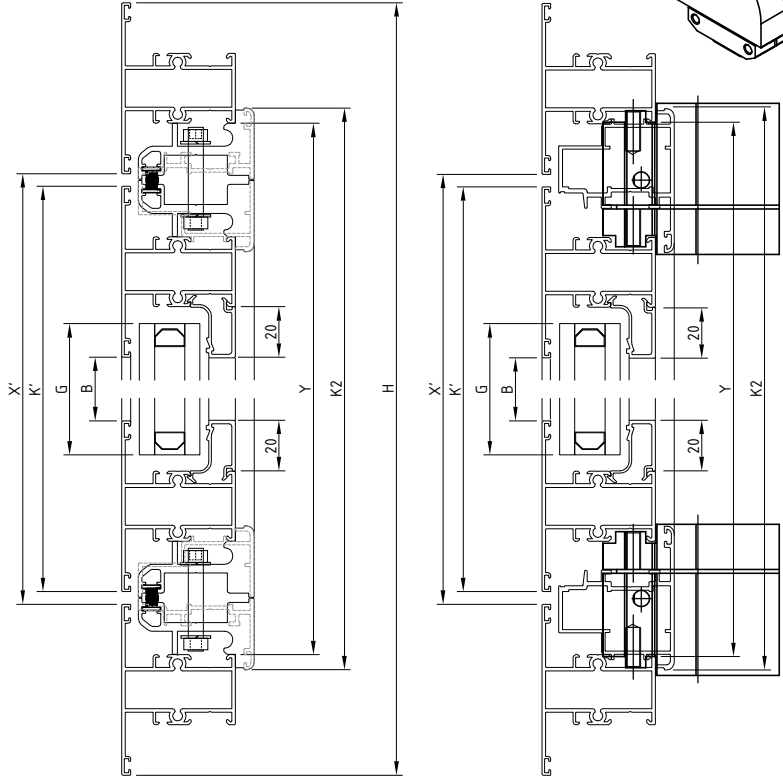

W10

W 45-1.4 YALITIMSIZ SERİ

W45-1.4 UNINSULATED SERIES

İMALAT ŞEMASI

PRODUCTION PLAN

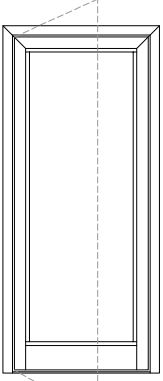

İÇERİ ACILAN KAPI
INSIDE OPENING DOOR

$$K1 = X + 12$$

$$K2 = Y + 6 - 15$$

$$G = B + 28$$

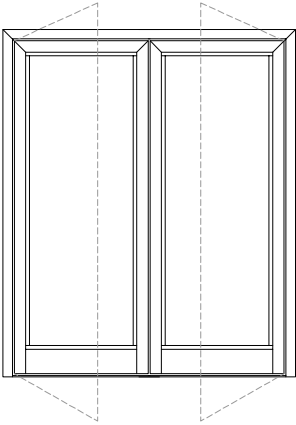
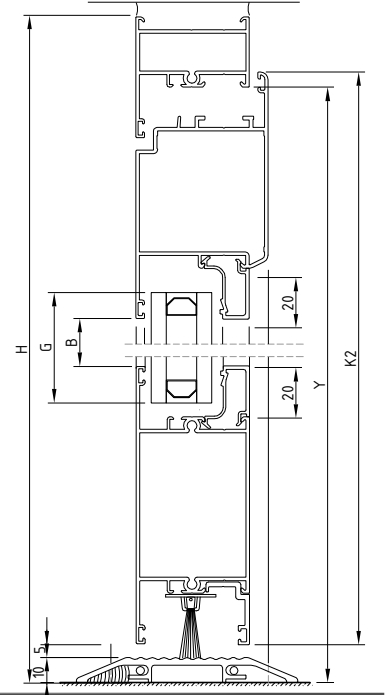
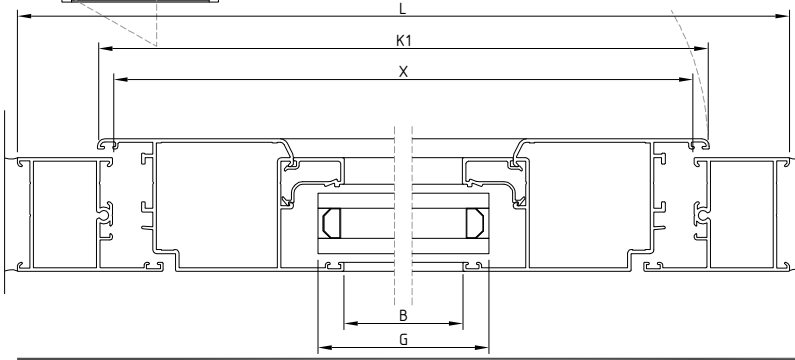

ÇİFT KANAT İÇERİ ACILAN KAPI
DOUBLE INSIDE OPENING DOOR

$$K1 = \frac{X + 12 - 5}{2}$$

$$K2 = Y + 6 - 15$$

$$G = B + 28$$

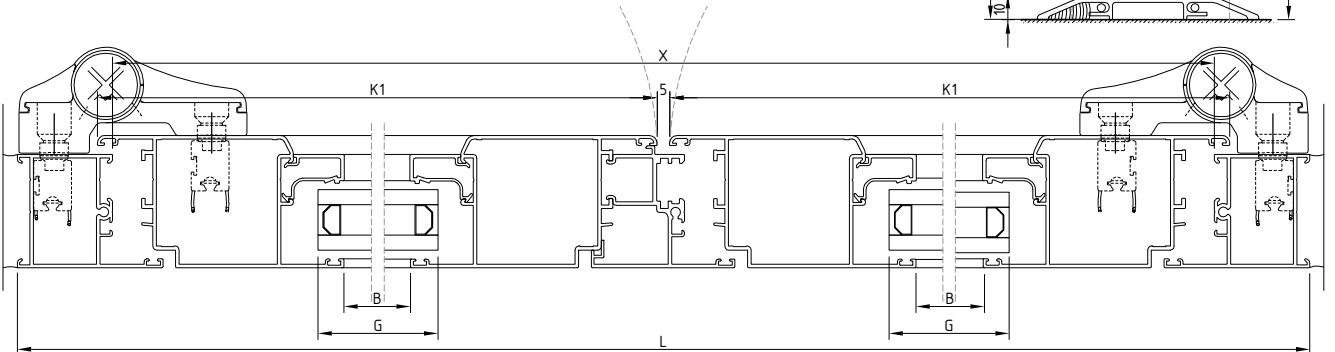
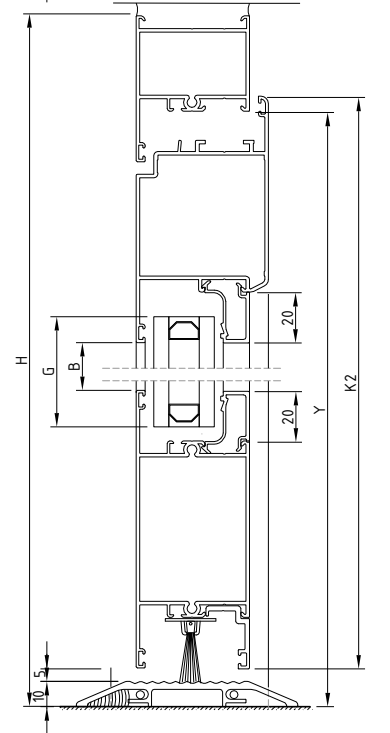

W10

W 45-1.4 YALITIMSIZ SERİ

W45-1.4 UNINSULATED SERIES

İMALAT ŞEMASI

PRODUCTION PLAN

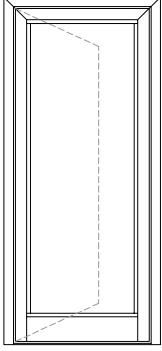

DIŞA ACILAN KAPI
OUTSIDE OPENING DOOR

$$K1 = X + 12$$

$$K2 = Y + 6 - 15$$

$$G = B + 28$$

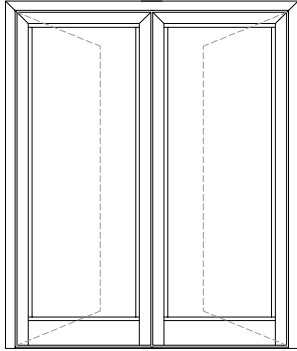
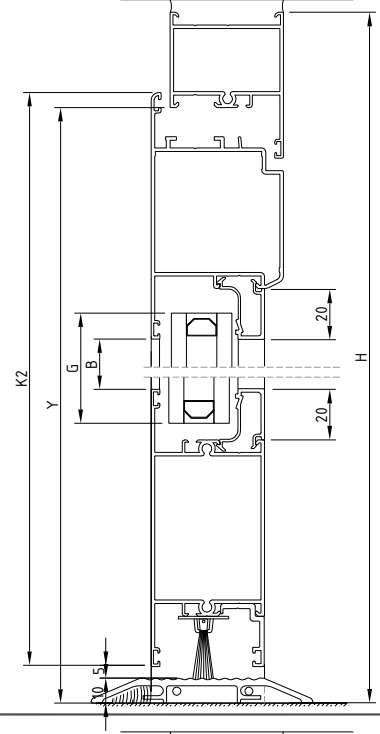
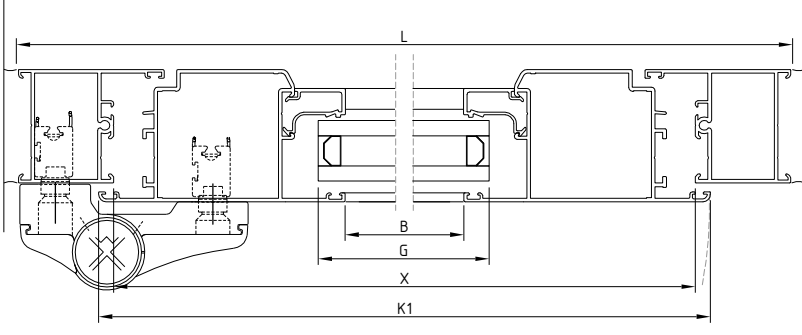

ÇİFT KANAT DIŞARI ACILAN KAPI
DOUBLE OUTSIDE OPENING DOOR

$$K1 = \frac{X + 12 - 5}{2}$$

$$K2 = Y + 6 - 15$$

$$G = B + 28$$

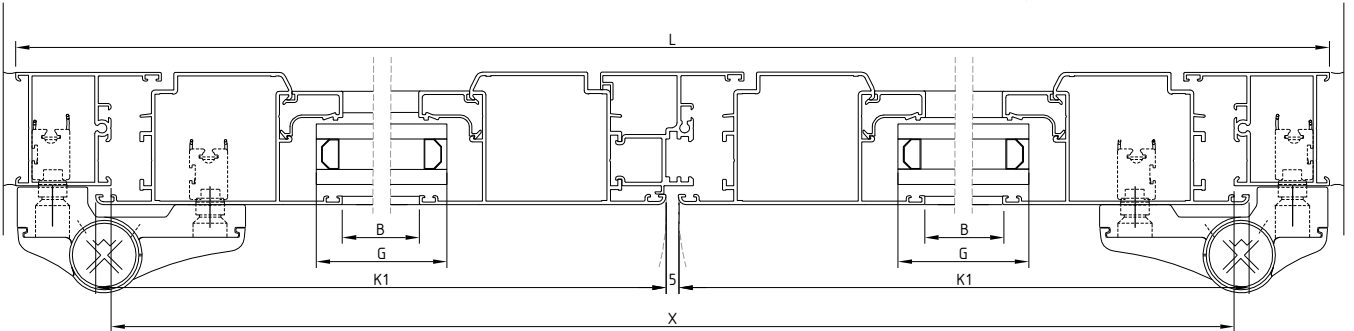
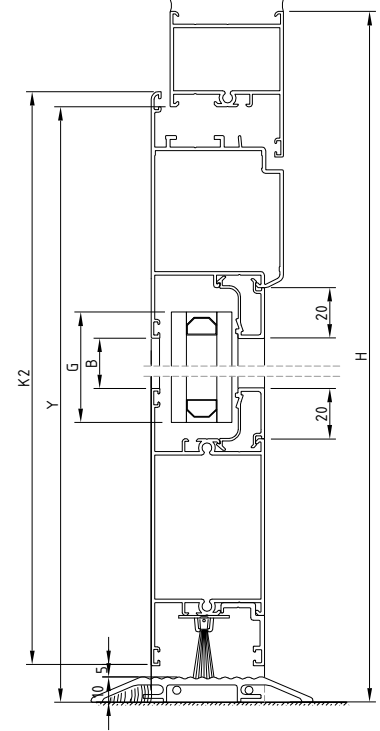

W 45 SERİ PROFİLLERİ

W45 PROFILES SERIE

Fıtıl listesi

Gasket list

kod code	şekil drawing	tanım description	teorik ağırlık teoretical weight gr / m	paket ağırlığı package weight kg / package	paket metrajı in one package metre / package	kullanım yeri aplication
W-702		epdm cam iç fıtıl glazing gasket inside	49 gr/m	15 kg	306 m	
W-703		epdm çarpma iç-dış fıtıl glazing acoustical (epdm)	33 gr/m	15 kg	440 m	
W-704		epdm cam dış fıtıl glazing gasket outside (epdm)	50 gr/m	15 kg	300 m	
W10-705		epdm tozluk fıtıl central gasket (epdm)	69 gr/m	15 kg	217 m	
W10-706		köşe tozluk fıtıl central gasket (epdm)	5,6 gr/m	-	50 ad-pcs	
W-707		epdm etek fıtılı gasket under profile	58 gr/m	15 kg	258 m	
W-708		Profil iç fıtıl Profile gasket inside	91 gr/m	15 kg	165 m	

W 45 SERİ PROFİLLERİ

W45 PROFILES SERIE

Fıtıl listesi

Gasket list

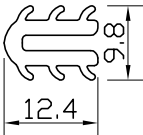
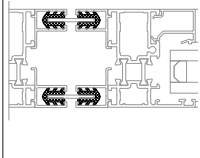
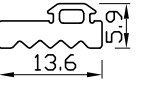
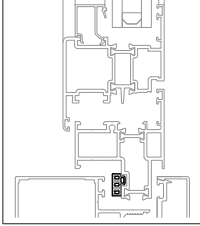
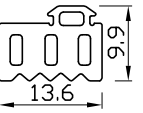
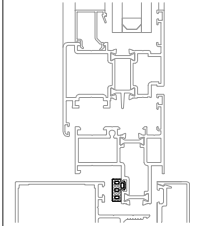
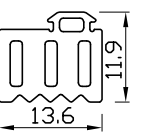
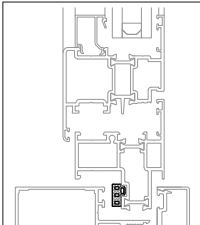
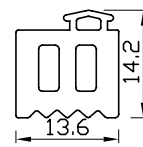
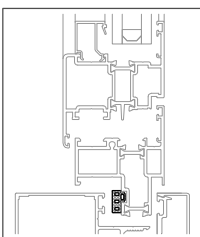
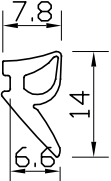
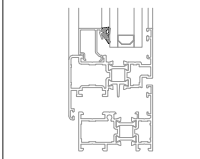
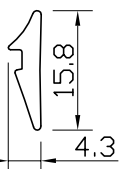
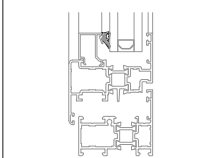
kod code	şekil drawing	tanım description	teorik ağırlık teoretical weight gr / m	paket ağırlığı package weight kg / package	paket metrajı in one package metre / package	kullanım yeri aplication
W-709		profil ara fıtıl gasket between profile (epdm)	82 gr/m	15 kg	183 m	
W-711		Profil iç fıtıl Profile gasket inside	65 gr/m	15 kg	230 m	
W-712		Profil iç fıtıl Profile gasket inside	110 gr/m	15 kg	135 m	
W-713		Profil iç fıtıl Profile gasket inside	135 gr/m	15 kg	110 m	
W-714		Profil iç fıtıl Profile gasket inside	166 gr/m	15 kg	90 m	
W-717		epdm cam iç fıtıl glazing gasket inside	69 gr/m	15 kg	217 m	
W-718		epdm cam iç fıtıl glazing gasket inside	52 gr/m	15 kg	288 m	

W 45 SERİ PROFİLLERİ

W45 PROFILES SERIE

Fıtıl listesi

Gasket list

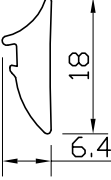
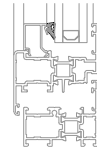
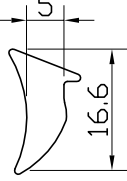
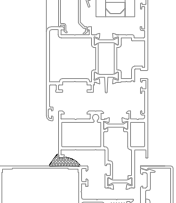
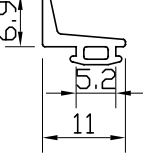
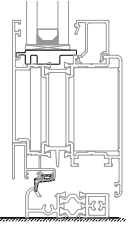
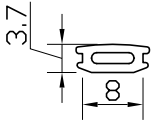
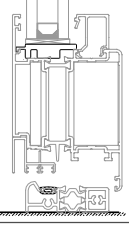
kod code	şekil drawing	tanım description	teorik ağırlık theoretical weight gr / m	paket ağırlığı package weight kg / package	paket metraji in one package metre / package	kullanım yeri aplication
W-719		epdm cam iç fıtıl glazing gasket inside	88 gr/m	15 kg	170 m	
SC0417		kasa alt fıtıl safe gasket inside (epdm)	96 gr/m	15 kg	156 m	
W-721		Eşik Fıtılı gasket threshold profile	40 gr/m	15 kg	375 m	
W-722		Eşik Fıtılı gasket threshold profile	30 gr/m	15 kg	500 m	

AKSESUARLAR ACCESSOIRES

PENCERE VE KAPI AÇILIM MEKANİZMALARI WINDOW AND DOOR OPENING MECHANISMS

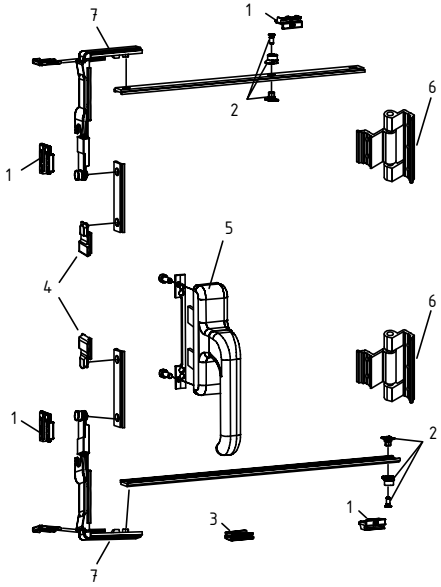

Normal açılım mekanizması (takım)
Opening window mechanism (set)

W-800		
1	Pim karşılığı	W-876
2	Ayarlı karşılık	W-879
3	Kanat sarkma takozu	W-887
4	Kol karşılığı	W-877
5	Çift dilli kol	W-857
6	Menteşe	W-833
+		
>1200 x 1400 mm		
7	Köşe dönme	W-875

W-801		
1	Pim karşılığı	W-876
2	Ayarlı karşılık	W-879
3	Kanat sarkma takozu	W-887
4	Kol karşılığı	W-877
5	Çift dilli kol	W-858
6	Menteşe	W-834
+		
>1200 x 1400 mm		
7	Köşe dönme	W-875

(renk seçeneği belirtilmelidir)
(colour choice must be stated)

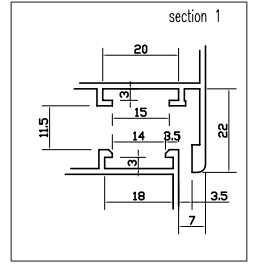
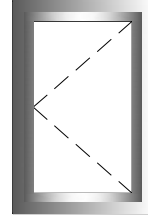

W-800 (ithal) (import) W-800-a (yerli) (native) naturel eloksalli (mat anodized)
W-801 (ithal) (import) W-801-a (yerli) (native) pres veya renkli (mill finish and painted)

Çift açılım mekanizması (takım)
Tilt and turn window mechanism (set)

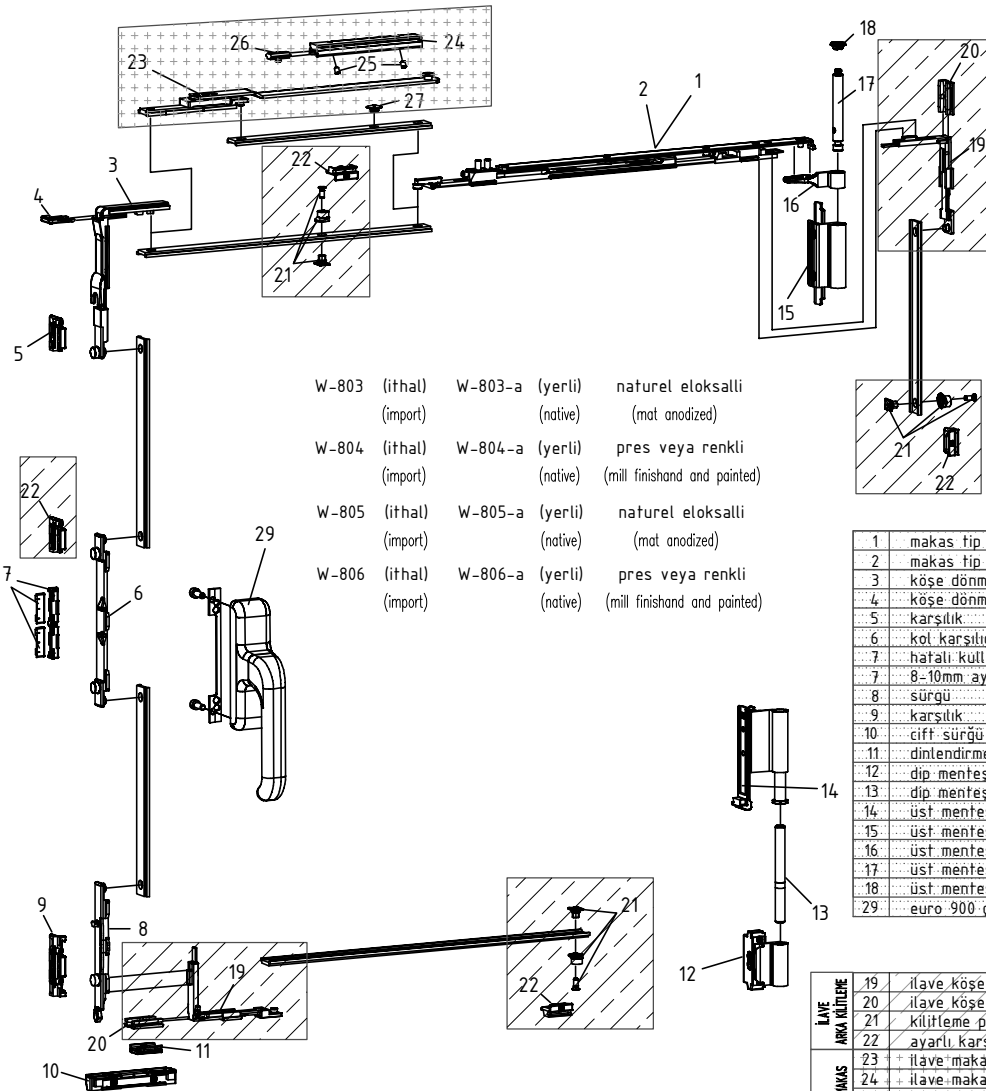

W-803 (ithal) (import) W-803-a (yerli) (native) naturel eloksalli (mat anodized)
W-804 (ithal) (import) W-804-a (yerli) (native) pres veya renkli (mill finish and painted)
W-805 (ithal) (import) W-805-a (yerli) (native) naturel eloksalli (mat anodized)
W-806 (ithal) (import) W-806-a (yerli) (native) pres veya renkli (mill finish and painted)

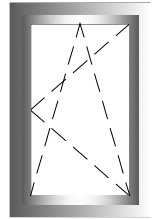
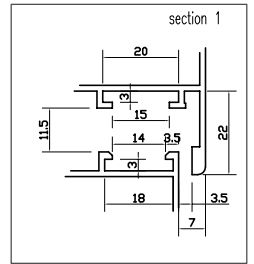

	W-805 (80 kg)	W-803 (130 kg)
1	makas tip 1 (küçük)	W-884-80 W-884-130
2	makas tip 2 (büyük)	W-881-80 W-881-130
3	köşe dönme	
4	köşe dönme sabitleme klipsi	
5	karşılık	
6	kol karşılığı	
7	hatalı kullanım öneme karşılığı	
7	8-10mm ayar simi	W-803LOCK W-803LOCK
8	sürgü	
9	karşılık	
10	çift sürgü karşılık	
11	dinlendirme takozu	
12	dip menteşe erkek kısmı	
13	dip menteşe pimi	
14	üst menteşe dişi kısmı	W-845HINGES W-842HINGES
15	üst menteşe erkek kısmı	W-845HINGES W-842HINGES
16	üst menteşe dişi kısmı	
17	üst menteşe pimi	
18	üst menteşe stoper kapak	
29	euro 900 çift açılım kolu	W-872 W-872

+
>80kg - 130kg

+		
19	ilave köşe dönme	
20	ilave köşe dönme sabitleme klipsi	W-880-1 W-880-1
21	kilitleme pimi	
22	ayarlı karşılık	
23	ilave makas	
24	ilave makas kilavuzu	
25	klavuz vidaları	W-880
26	ayarlı stoper	
27	makas destek bloğu	

AKSESUARLAR ACCESSOIRES

PENCERE VE KAPI AÇILIM MEKANİZMALARI WINDOW AND DOOR OPENING MECHANISMS

Locking mechanism UNI-JET C and D - Side hung fittings - 1 sash
Fixed gear position, groove position 9mm

Normal açılım PVC mekanizması (takım)
PVC opening window mechanism (set)

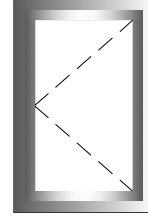

Basic security

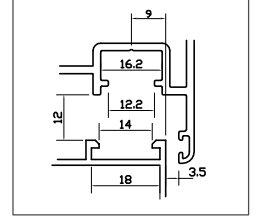

yükseklik (height):	kanat genişliği (width):					
	280-500	501-750	701-1000	1001-1200**	1201-1450**	1451-1600**
480-590	1	2	3	4	5	6
591-750	7	8	9	10	11	12
751-1200	13	14	15	16	17	18
951-1450 *	19	20	21	22	23	24
1201-1700 *	25	26	27	28	29	30
1451-1950 *	31	32	33	34	35	36
1951-2450*	37	38	39	40	41	

* arka kilitlemeli
** yatay kilitlemeli

(renk seçeneği belirtilmelidir)
(colour choice must be stated)

W-807 (ithal) W-807-a (yerli) naturel eloksalli
(import) (native) (mat anodized)
W-808 (ithal) W-808-a (yerli) pres veya renkli
(import) (native) (mill finish and painted)

Örnek kod tesbiti
Example

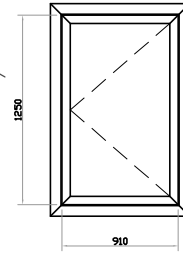

sipariş kodu
order code

W-807-27 (ithal)
(import)

W-807-27-a (yerli)
(native)

Locking mechanism UNI-JET C and D - Tilt-turn fittings - 1 sash
Fixed gear position, groove position 9mm

Çift açılım PVC mekanizması (takım)
PVC tilt and turn window mechanism (set)

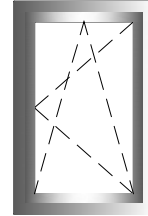

Basic security

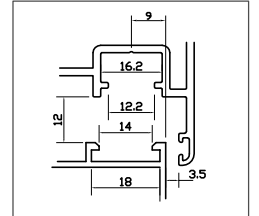

W-809 (ithal) W-809-a (yerli) naturel eloksalli
(import) (native) (mat anodized)
W-810 (ithal) W-810-a (yerli) pres veya renkli
(import) (native) (mill finish and painted)

yükseklik (height):	kanat genişliği (width):					
	280-500	501-750	701-1000	1001-1200**	1201-1450**	1451-1600**
480-590	1	2	3	4	5	6
591-750	7	8	9	10	11	12
751-1200	13	14	15	16	17	18
951-1450 *	19	20	21	22	23	24
1201-1700 *	25	26	27	28	29	30
1451-1950 *	31	32	33	34	35	36
1951-2450*	37	38	39	40	41	

* arka kilitlemeli
** yatay kilitlemeli

(renk seçeneği belirtilmelidir)
(colour choice must be stated)

AKSESUARLAR ACCESSOIRES

PENCERE VE KAPI AÇILIM MEKANİZMALARI WINDOW AND DOOR OPENING MECHANISMS

Locking mechanism UNI-JET C and D Inactive sash fittings ZH
Fixed gear position, groove position 9mm



W-811	(ithal) (import)	W-811-a	(yerli) (native)	naturel eloksalli (mat anodized)
W-812	(ithal) (import)	W-812-a	(yerli) (native)	pres veya renkli (mill finishand and painted)

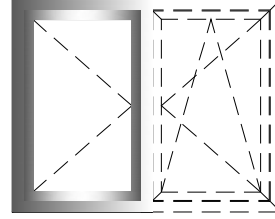

Basic security

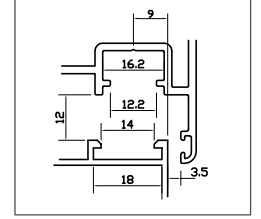

Normal açılım PVC mekanizması (takım)
PVC opening window mechanism (set)

kanat genişliği (width):

yükseklik (height):	kanat genişliği (width):					
	280-500	501-750	701-1000	1001-1200**	1201-1450**	1451-1600**
480-590	1	2	3	4	5	6
591-750	7	8	9	10	11	12
751-1200	13	14	15	16	17	18
951-1450 *	19	20	21	22	23	24
1201-1700 *	25	26	27	28	29	30
1451-1950 *	31	32	33	34	35	36
1951-2450*	37	38	39	40	41	

* arka kilitlemeli

** yatay kilitlemeli

(renk seçeneği belirtilmelidir)
(colour choice must be stated)

Locking mechanism UNI-JET C and D - Tilt-turn fittings - 2 sashes
Fixed gear position, groove position 9mm

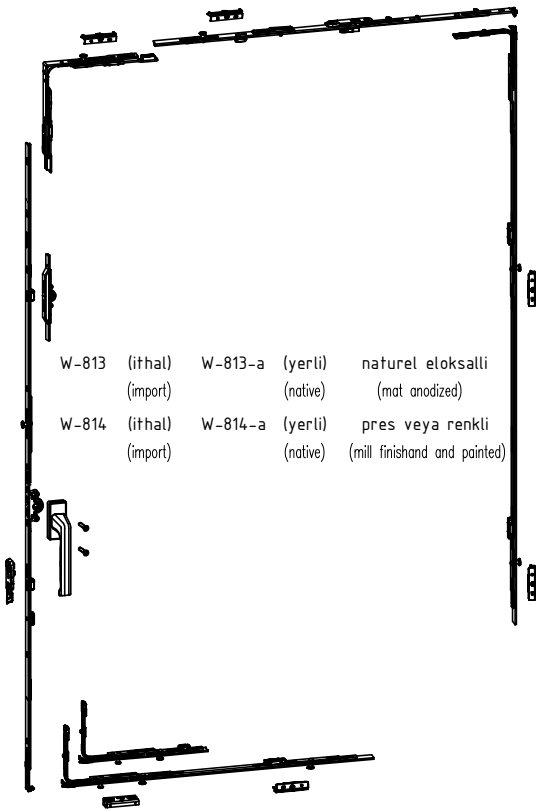

W-813	(ithal) (import)	W-813-a	(yerli) (native)	naturel eloksalli (mat anodized)
W-814	(ithal) (import)	W-814-a	(yerli) (native)	pres veya renkli (mill finishand and painted)

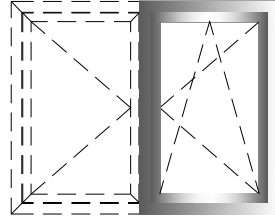

Basic security

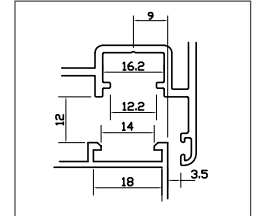

Çift açılım PVC mekanizması (takım)
PVC tilt and turn window mechanism (set)

kanat genişliği (width):

yükseklik (height):	kanat genişliği (width):					
	280-500	501-750	701-1000	1001-1200**	1201-1450**	1451-1600**
480-590	1	2	3	4	5	6
591-750	7	8	9	10	11	12
751-1200	13	14	15	16	17	18
951-1450 *	19	20	21	22	23	24
1201-1700 *	25	26	27	28	29	30
1451-1950 *	31	32	33	34	35	36
1951-2450*	37	38	39	40	41	

* arka kilitlemeli

** yatay kilitlemeli

(renk seçeneği belirtilmelidir)
(colour choice must be stated)

AKSESUARLAR ACCESSOIRES

PENCERE VE KAPI AÇILIM MEKANİZMALARI WINDOW AND DOOR OPENING MECHANISMS

Locking mechanism UNI-JET C and D - Side hung fittings - 2 sashes
Fixed gear position, groove position 9mm

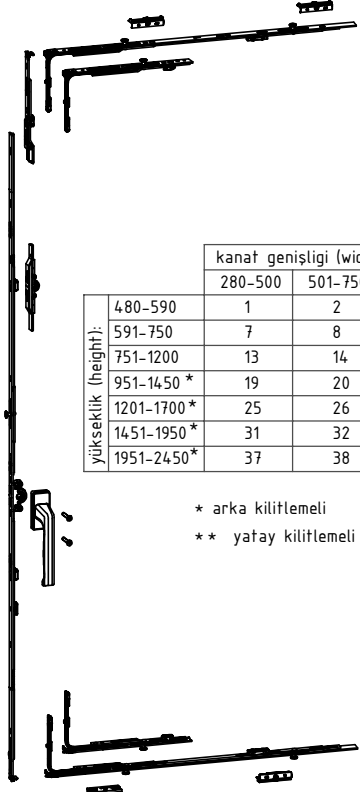

Normal açılım PVC mekanizması (takım)
PVC opening window mechanism (set)

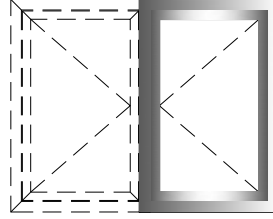

Basic security

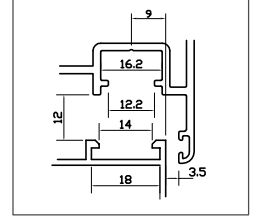

	kanat genişliği (width):					
	280-500	501-750	701-1000	1001-1200**	1201-1450**	1451-1600**
yükseklik (height):						
480-590	1	2	3	4	5	6
591-750	7	8	9	10	11	12
751-1200	13	14	15	16	17	18
951-1450 *	19	20	21	22	23	24
1201-1700 *	25	26	27	28	29	30
1451-1950 *	31	32	33	34	35	36
1951-2450*	37	38	39	40	41	

W-815 (ithal) (import) W-815-a (yerli) (native) naturel eloksalı (mat anodized)
W-816 (ithal) (import) W-816-a (yerli) (native) pres veya renkli (mill finish and painted)

* arka kilitlemeli
** yatay kilitlemeli

(renk seçeneği belirtilmelidir)
(colour choice must be stated)

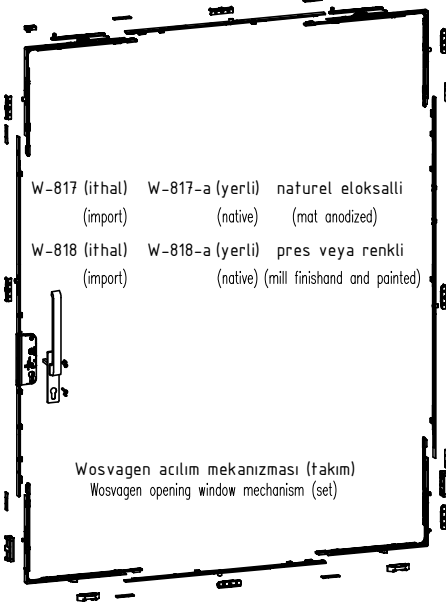
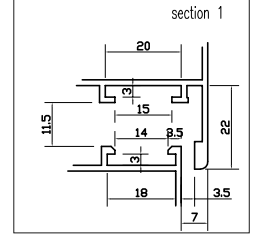
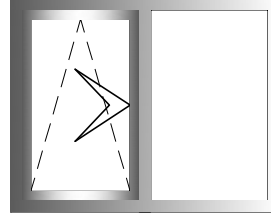

W-817 (ithal) (import) W-817-a (yerli) (native) naturel eloksalı (mat anodized)
W-818 (ithal) (import) W-818-a (yerli) (native) pres veya renkli (mill finish and painted)

Wosvagen açılım mekanizması (takım)
Wosvagen opening window mechanism (set)

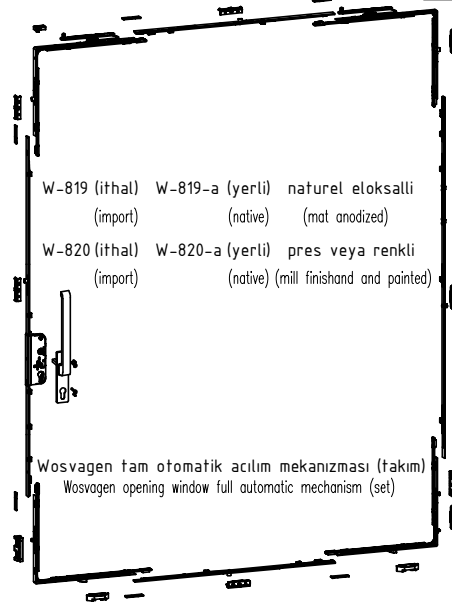

W-819 (ithal) (import) W-819-a (yerli) (native) naturel eloksalı (mat anodized)
W-820 (ithal) (import) W-820-a (yerli) (native) pres veya renkli (mill finish and painted)

Wosvagen tam otomatik açılım mekanizması (takım)
Wosvagen opening window full automatic mechanism (set)

(renk seçeneği belirtilmelidir)
(colour choice must be stated)

AKSESUARLAR ACCESSOIRES

PENCERE VE KAPI AÇILIM MEKANİZMALARI WINDOW AND DOOR OPENING MECHANISMS

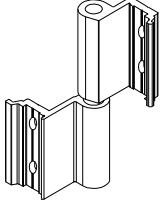

İki yapraklı pencere menteşesi
Two leaves window hinge

W-830 (ithal) (import)	W-830-a (yerli) (native)	naturel eloksalli (mat anodized)
W-831 (ithal) (import)	W-831-a (yerli) (native)	pres veya renkli (mill finishand and painted)

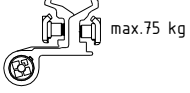

max.75 kg

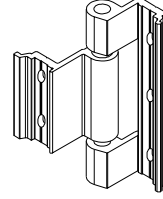

Üç yapraklı pencere menteşesi
Three leaves window hinge

W-833 (yerli) (native)	naturel eloksalli (mat anodized)
W-834 (yerli) (native)	pres veya renkli (mill finishand and painted)



max.75 kg

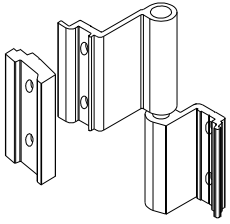

İki yapraklı normal açılım pvc pencere menteşesi
Two leaves PVC window hinge

W-836 (ithal) (import)	W-836-a (yerli) (native)	naturel eloksalli (mat anodized)
W-837 (ithal) (import)	W-837-a (yerli) (native)	pres veya renkli (mill finishand and painted)

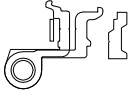

max.75 kg

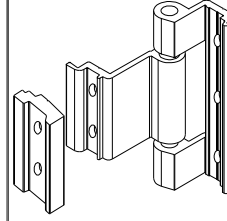

Üç yapraklı normal açılım pvc pencere menteşesi
Three leaves PVC window hinge

W-839 (yerli) (native)	naturel eloksalli (mat anodized)
W-840 (yerli) (native)	pres veya renkli (mill finishand and painted)

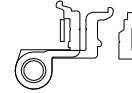

max.75 kg

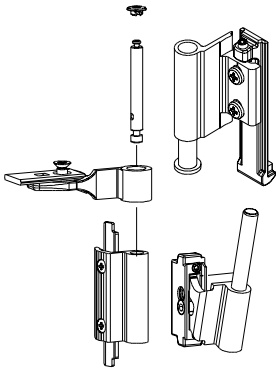

Çift açılım pencere üst menteşesi (130kg)
Tilt and turn window top hinge (130kg)

W-842HINGES (ithal) (import)	naturel eloksalli (mat anodized)
W-843HINGES (ithal) (import)	pres veya renkli (mill finishand and painted)

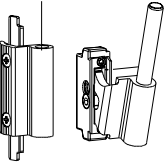

Çift açılım pencere üst menteşesi (80kg)
Tilt and turn window top hinge (80kg)

W-845HINGES (ithal) (import)	naturel eloksalli (mat anodized)
W-846HINGES (ithal) (import)	pres veya renkli (mill finishand and painted)

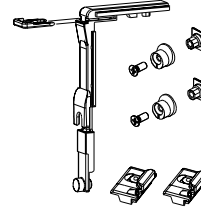

ÇİFT AÇILIM İLAVE KİLİTLEME
TILT AND TURN ANNEX SET

W-880-1 (ithal) (import)

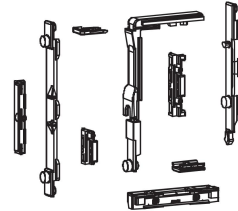

ÇİFT AÇILIM KİLİTLEME MEKANİZMA
TILT AND TURN BASE MECHANISM

W-803LOCK (ithal) (import)

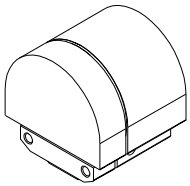

Pivot menteşe
Hung window hinge

W-848 (ithal) (import)	W-848-a (yerli) (native)	naturel eloksalli (mat anodized)
W-849 (ithal) (import)	W-849-a (yerli) (native)	pres veya renkli (mill finishand and painted)

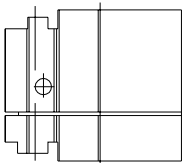

Pivot menteşe
Hung window hinge

W-851 (yerli) (native)	naturel eloksalli	W1-W2-W3-W4
W-852 (yerli) (native)	pers-renkli boyalı	
W65-851 (yerli) (native)	naturel eloksalli	W5-W6
W65-852 (yerli) (native)	pers-renkli boyalı	
W75-851 (yerli) (native)	naturel eloksalli	W7-W8
W75-852 (yerli) (native)	pers-renkli boyalı	
W45-851 (yerli) (native)	naturel eloksalli	W9-W10
W45-852 (yerli) (native)	pers-renkli boyalı	

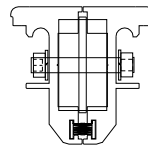

AKSESUARLAR ACCESSOIRES

PENCERE VE KAPI AÇILIM MEKANİZMALARI WINDOW AND DOOR OPENING MECHANISMS

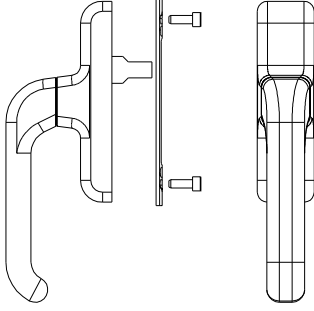

Tek maçalı normal açılım pencere kolu
Opening window handle

W-854 (yerli) (native)	W-854-a (yerli) (native)	naturel eloksalli (mat anodized)
W-855 (yerli) (native)	W-855-a (yerli) (native)	pres veya renkli (mill finishand and painted)

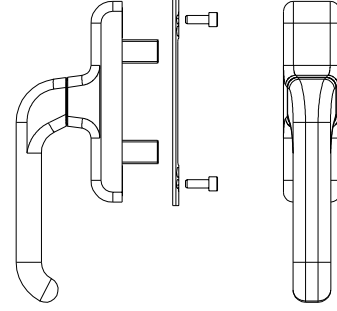

Çift maçalı normal açılım pencere kolu
Opening window handle

W-857 (ithal) (import)	W-857-a (yerli) (native)	naturel eloksalli (mat anodized)
W-858 (ithal) (import)	W-858-a (yerli) (native)	pres veya renkli (mill finishand and painted)



Anahtarlı aksenal kol
Key lockable window handle

W-860 (ithal) (import)	W-860-a (yerli) (native)	naturel eloksalli (mat anodized)
W-861 (ithal) (import)	W-861-a (yerli) (native)	pres veya renkli (mill finishand and painted)



Sökülebilir kol gövde
Opening window removing handle

W-863 (ithal) (import)	W-863-a (yerli) (native)	naturel eloksalli (mat anodized)
W-864 (ithal) (import)	W-864-a (yerli) (native)	pres veya renkli (mill finishand and painted)

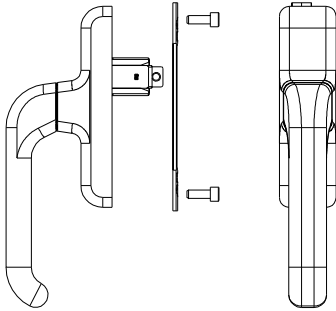

Çift açılım pencere kolu
Tilt and turn opening window handle

W-872 (ithal) (import)	W-872-a (yerli) (native)	naturel eloksalli (mat anodized)
W-873 (ithal) (import)	W-873-a (yerli) (native)	pres veya renkli (mill finishand and painted)

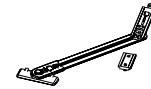

Limitleme makası (küçük)
Window stay (small)

W-886K (ithal) (import)	W-886K-a (yerli) (native)
-----------------------------------	-------------------------------------



Limitleme makası (büyük)
Window stay (big)

W-886 (ithal) (import)	W-886-a (yerli) (native)
----------------------------------	------------------------------------

AKSESUARLAR ACCESSOIRES

PENCERE VE KAPI AÇILIM MEKANİZMALARI WINDOW AND DOOR OPENING MECHANISMS

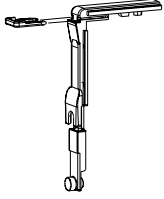

Köşe hareket aktarıcı
Corner transmission for window

W-875 (ithal) W-875-a (yerli)
(import) (native)



Pim karşılığı
Adjustable single striker

W-876 (ithal) W-876-a (yerli)
(import) (native)

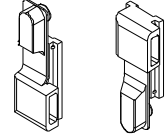

Tij bağlantı pabucu
Connection blocks

W-877 (ithal) W-877-a (yerli)
(import) (native)



Pim
Pin

W-878 (ithal) W-878-a (yerli)
(import) (native)

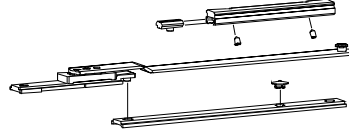

Çift açılım ilave makas
Tilt and turn annex arm

W-880 (ithal) W-880-a (yerli)
(import) (native)



Kol karşılığı
Cremone drive

W-882 (ithal)
(import)
W-882-a (yerli)
(native)



Sürgü ucu
Bolt tip

W-883 (ithal)
(import)
W-883-a (yerli)
(native)

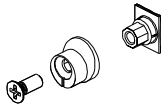

Ayarlanabilir pim
Adjustable fastening pawl

W-879 (ithal) W-879-a (yerli)
(import) (native)

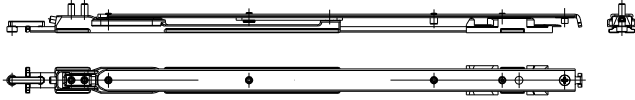

Çift açılım büyük makas (130kg)
Tilt and turn long arm (130kg)

W-881-80 (ithal) W-881-80-a (yerli) W-881-130 (ithal) W-881-130-a (yerli)
(import) (native) (import) (native)

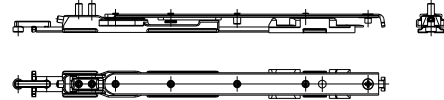

Çift açılım küçük makas (80kg)
Tilt and turn short arm (80kg)

W-884-80 (ithal) W-884-80-a (yerli) W-884-130 (ithal) W-884-130-a (yerli)
(import) (native) (import) (native)



Kademeli teleskopik makas (inox)
Telescopic laser unit

W-885 (ithal) W-885-a (yerli)
(import) (native)



Kanat sarkma takozu
Wing rise stopper

W-887 (ithal)
(import)
W-887-a (yerli)
(native)



Çiftli sürgü karşılığı
Double keeper

W-888 (ithal)
(import)
W-888-a (yerli)
(native)



Kanat düşüş karşılığı
Wing drop keeper

W-889 (ithal)
(import)
W-889-a (yerli)
(native)

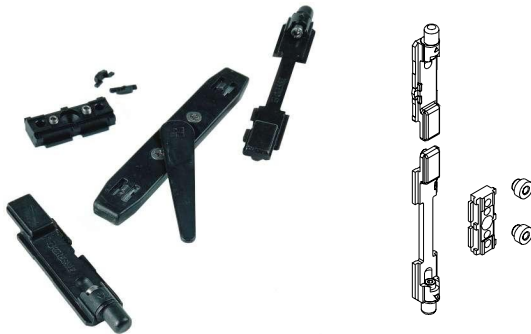

İkinci kanat sürge seti
Two-way lever push bolt

W-893 (ithal)
(import)
W-893-a (yerli)
(native)

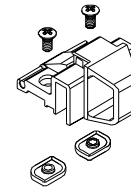

Vasistas cit cit
Cico finger catch

W-894 (ithal) W-894-a (yerli) naturel eloksalı
(import) (native) (mat anodized)
W-895 (ithal) W-895-a (yerli) pres veya renkli
(import) (native) (mill finish and painted)

AKSESUARLAR ACCESSOIRES

PENCERE VE KAPI AÇILIM MEKANİZMALARI WINDOW AND DOOR OPENING MECHANISMS

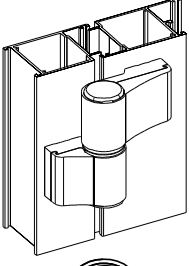

İki yapraklı kapı menteşesi
Two-leaf hinges for door

- | | | |
|---------------------------|-----------------------------|---|
| D-800 (ithal)
(import) | D-800-a (yerli)
(native) | naturel eloksalli
(mat anodized) |
| D-801 (ithal)
(import) | D-801-a (yerli)
(native) | pres veya renkli
(mill finish and painted) |

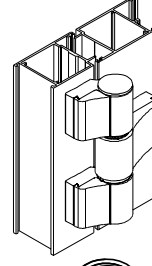

Üç yapraklı kapı menteşesi
Three-leaf hinges for door

- | | | |
|---------------------------|-----------------------------|---|
| D-803 (ithal)
(import) | D-803-a (yerli)
(native) | naturel eloksalli
(mat anodized) |
| D-804 (ithal)
(import) | D-804-a (yerli)
(native) | pres veya renkli
(mill finish and painted) |

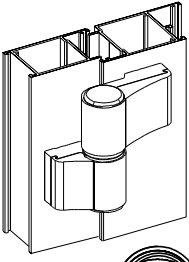

İki yapraklı kapı menteşesi
Two-leaf hinges for door

- | | | |
|---------------------------|-----------------------------|---|
| D-806 (ithal)
(import) | D-806-a (yerli)
(native) | naturel eloksalli
(mat anodized) |
| D-807 (ithal)
(import) | D-807-a (yerli)
(native) | pres veya renkli
(mill finish and painted) |

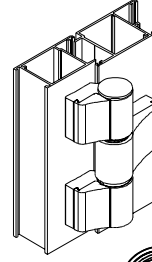

Üç yapraklı kapı menteşesi
Three-leaf hinges for door

- | | | |
|---------------------------|-----------------------------|---|
| D-809 (ithal)
(import) | D-809-a (yerli)
(native) | naturel eloksalli
(mat anodized) |
| D-810 (ithal)
(import) | D-810-a (yerli)
(native) | pres veya renkli
(mill finish and painted) |



Menteşe kademe yükseltici
Step for hinges

- | | | |
|---------------------------|-----------------------------|---|
| D-888 (ithal)
(import) | D-888-a (yerli)
(native) | naturel eloksalli
(mat anodized) |
| D-889 (ithal)
(import) | D-889-a (yerli)
(native) | pres veya renkli
(mill finish and painted) |

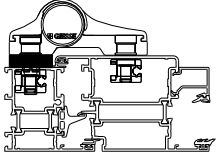

Menteşe kademe yükseltici
Step for hinges

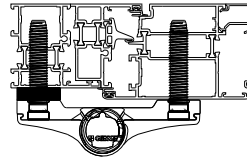

- | | | |
|---------------------------|-----------------------------|---|
| D-890 (ithal)
(import) | D-890-a (yerli)
(native) | naturel eloksalli
(mat anodized) |
| D-891 (ithal)
(import) | D-891-a (yerli)
(native) | pres veya renkli
(mill finish and painted) |

İki yapraklı kapı menteşesi için bağlantı takımı
Two-leaf hinges door for counterplates

- | | | |
|---------------------------|-----------------------------|-------------------------------------|
| D-892 (ithal)
(import) | D-892-a (yerli)
(native) | naturel eloksalli
(mat anodized) |
|---------------------------|-----------------------------|-------------------------------------|

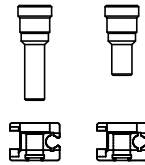
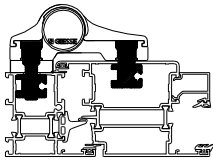

İki yapraklı kapı menteşesi için bağlantı takımı
Two-leaf hinges door for counterplates

- | | | |
|---------------------------|-----------------------------|-------------------------------------|
| D-893 (ithal)
(import) | D-893-a (yerli)
(native) | naturel eloksalli
(mat anodized) |
|---------------------------|-----------------------------|-------------------------------------|

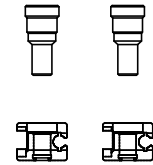
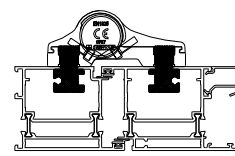

Üç yapraklı kapı menteşesi için bağlantı takımı
Three-leaf hinges door for counterplates

- | | | |
|---------------------------|-----------------------------|-------------------------------------|
| D-894 (ithal)
(import) | D-894-a (yerli)
(native) | naturel eloksalli
(mat anodized) |
|---------------------------|-----------------------------|-------------------------------------|

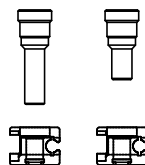
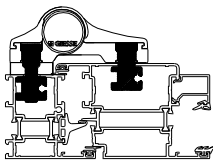

Üç yapraklı kapı menteşesi için bağlantı takımı
Three-leaf hinges door for counterplates

- | | | |
|---------------------------|-----------------------------|-------------------------------------|
| D-895 (ithal)
(import) | D-895-a (yerli)
(native) | naturel eloksalli
(mat anodized) |
|---------------------------|-----------------------------|-------------------------------------|

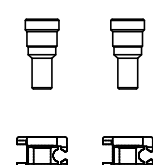
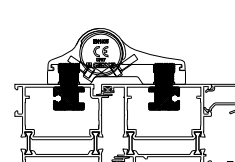

AKSESUARLAR ACCESSOIRES

PENCERE VE KAPI AÇILIM MEKANİZMALARI WINDOW AND DOOR OPENING MECHANISMS

İki ve üç yapraklı kapı menteşesi için bağlantı
Two and three-leaf hinges door for counterplates

D-896 (ithal) D-896-a (yerli) naturel eloksalli
(import) (native) (mat anodized)

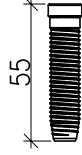
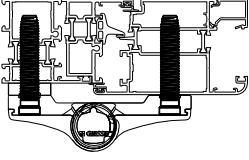

İki ve üç yapraklı kapı menteşesi için bağlantı
Two and three-leaf hinges door for counterplates

D-897 (ithal) D-897-a (yerli) naturel eloksalli
(import) (native) (mat anodized)

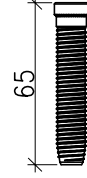
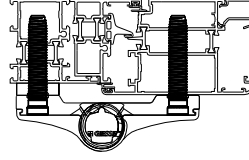

İki yapraklı kapı menteşesi (XL)
Two-leaf hinges for door (XL)

D-812 (ithal) D-812-a (yerli) naturel eloksalli
(import) (native) (mat anodized)
D-813 (ithal) D-813-a (yerli) pres veya renkli
(import) (native) (mill finish and painted)

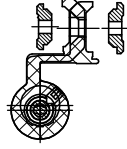

max.100 kg

Üç yapraklı kapı menteşesi (XXL)
Three-leaf hinges for door (XXL)

D-815 (ithal) D-815-a (yerli) naturel eloksalli
(import) (native) (mat anodized)
D-816 (ithal) D-816-a (yerli) pres veya renkli
(import) (native) (mill finish and painted)

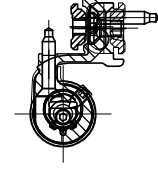

max.160 kg

Çarpma kapı menteşesi
Swinging door hinges

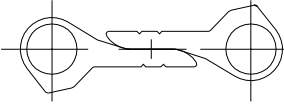

D-818 (ithal) D-818-a (yerli)
(import) (native)
D-819 (ithal) D-819-a (yerli)
(import) (native)

AKSESUARLAR ACCESSOIRES

PENCERE VE KAPI AÇILIM MEKANİZMALARI WINDOW AND DOOR OPENING MECHANISMS

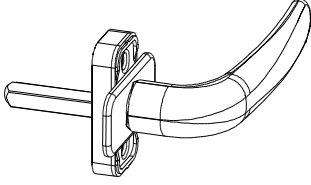

Prima kapı kolu
Prima handle

- D-821 (ithal) D-821-a (yerli) naturel eloksalli
(import) (native) (mat anodized)
- D-822 (ithal) D-822-a (yerli) pres veya renkli
(import) (native) (mill finishand and painted)

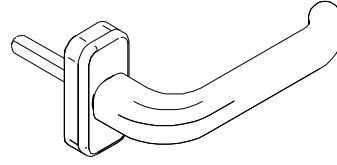

Prima kapı kolu (sağ-sol)
Prima handle (LH/RH)

- D-824 (ithal) D-824-a (yerli) naturel eloksalli
(import) (native) (mat anodized)
- D-825 (ithal) D-825-a (yerli) pres veya renkli
(import) (native) (mill finishand and painted)



Prima ikili kapı kolu
Prima handle couple

- D-827 (ithal) D-827-a (yerli) naturel eloksalli
(import) (native) (mat anodized)
- D-828 (ithal) D-828-a (yerli) pres veya renkli
(import) (native) (mill finishand and painted)



Supermaster ikili kapı kolu
Supermaster handle-couple

- D-830 (ithal) D-830-a (yerli) naturel eloksalli
(import) (native) (mat anodized)
- D-831 (ithal) D-831-a (yerli) pres veya renkli
(import) (native) (mill finishand and painted)

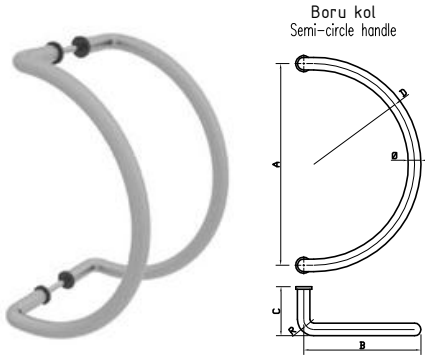

Boru kol
Semi-circle handle

- D-833-X
naturel eloksalli
(mat anodized)
- D-834-X
pres veya renkli
(mill finishand and painted)

X	Ø	R	A	B	C	D
1	20	25	110	110	60	55
2	20	25	150	130	60	75
3	20	25	200	140	60	100
4	25	40	200	150	80	100
5	25	40	300	210	80	150
6	25	40	400	250	80	200
7	30	55	300	250	80	150
8	30	55	350	250	80	175
9	32	55	300	250	80	150
10	32	55	350	175	80	175



Boru kol
Semi-circle curved handle

- D-836-X
naturel eloksalli
(mat anodized)
- D-837-X
pres veya renkli
(mill finishand and painted)

X	Ø	R	A	B	C
1	20	25	110	90	50
2	20	25	150	90	60
3	20	25	200	90	60
4	25	40	200	100	80
5	25	40	250	100	80
6	25	40	300	100	80
7	25	40	350	100	80
8	25	40	400	100	80
9	30	40	300	100	80
10	30	50	350	130	80
11	30	50	600	130	80
12	32	50	300	150	80
13	32	50	350	150	80



Boru kol
Spring handle

- D-839-X
naturel eloksalli
(mat anodized)
- D-840-X
pres veya renkli
(mill finishand and painted)

X	Ø	R	A	B	C
1	30	750	600	1500	75
2	30	750	750	1600	75

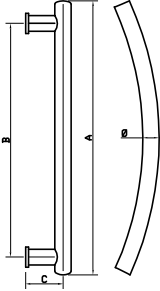

Düz-kıvrık aynalı kol
Flat-curve mirrored handles

- D-842-X
naturel eloksalli
(mat anodized)
- D-843-X
pres veya renkli
(mill finishand and painted)

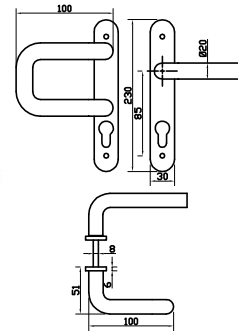

Lama bant kol
Lama stripe handle

- D-845-X
naturel eloksalli
(mat anodized)
- D-846-X
pres veya renkli
(mill finishand and painted)

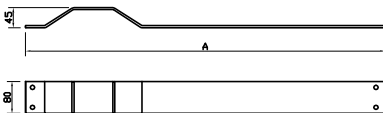

X	A
1	900
2	1000

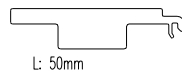

L: 50mm

Cam altı takozu (yerli)
Glass support piece (native)

- D-869 W1-W2-W3-W4-D1-D2
D65-869 W5-W6-S3
D75-869 W7-W8
D45-869 W9-W10

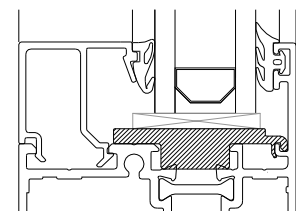

AKSESUARLAR ACCESSOIRES

PENCERE VE KAPI AÇILIM MEKANİZMALARI WINDOW AND DOOR OPENING MECHANISMS



Giesse panik kol
Panic bar mechanism

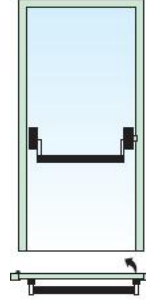

D-857
naturel eloksalli
(mat anodized)

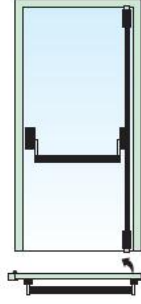

D-860
naturel eloksalli
(mat anodized)

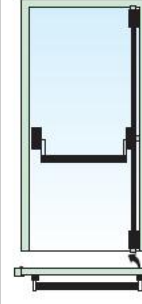

D-863
naturel eloksalli
(mat anodized)

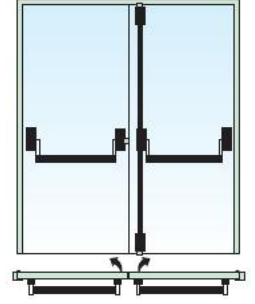

D-866
naturel eloksalli
(mat anodized)

D-858
pres veya renkli
(mill finishand and painted)

D-861
pres veya renkli
(mill finishand and painted)

D-864
pres veya renkli
(mill finishand and painted)

D-867
pres veya renkli
(mill finishand and painted)

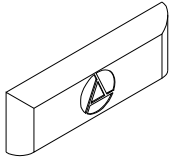

Pvc su tahliye parçası
Drainage hole cover

D-870 (yerli)
(native)

(renk secenegi belirtilmelidir)
(colour choice must be stated)

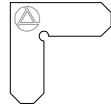

Köşe birleştirme aparatı
Shoulder aligning square

D-872 (yerli)
(native)

alüminyum 1.5mm

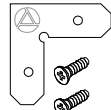

Köşe birleştirme aparatı
Shoulder aligning square

D-872-1 (yerli)
(native)

alüminyum 1.5mm

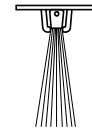

Kapı altı fırçası
Door brush

D-873 (yerli)
(native)

W8-501 profili ile kullanılır
it can use with W8-501

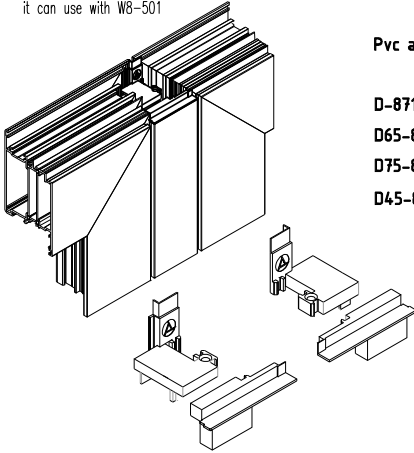

Pvc adaptör kapak (takım)
PVC adapter cover

D-871 W1-W2-W3-W4
D65-871 W5-W6
D75-871 W7-W8
D45-871 W9-W10

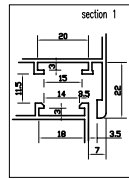

W8-501-a profili ile kullanılır
it can use with W8-501-a

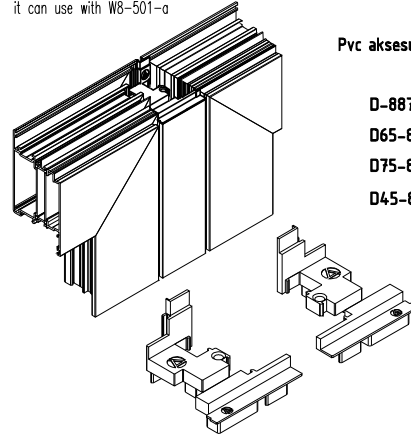

Pvc aksesuar kanal adaptör kapak (takım)
PVC adapter cover

D-887 W1-W2-W3-W4
D65-887 W5-W6
D75-887 W7-W8
D45-887 W9-W10

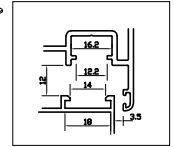

Dıştan uygulama kapı sürgüsü
Door lever bolt (from outside application)

D-882 (ithal) D-882-a (yerli) naturel eloksalli
(import) (native) (mat anodized)
D-883 (ithal) D-883-a (yerli) pres veya renkli
(import) (native) (mill finishand and painted)



Kapı sürgüsü
Door lever bolt

D-881 (ithal) D-881-a (yerli)
(import) (native)

AKSESUARLAR ACCESSOIRES

PENCERE VE KAPI AÇILIM MEKANİZMALARI WINDOW AND DOOR OPENING MECHANISMS

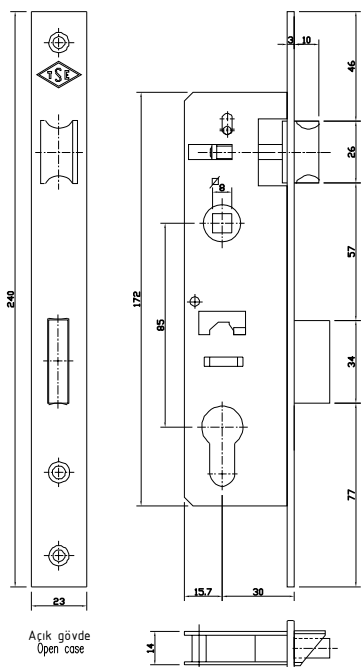

153U-30
Dar kilit(dilli)
Narrow lock (bolt)
D-874 (yerli) metalik
(native) metallic

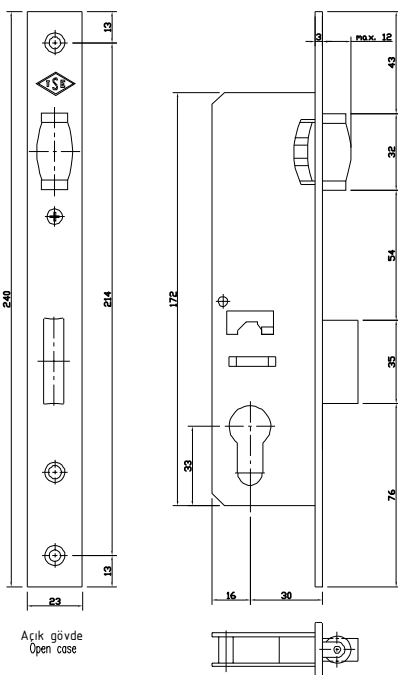

155U-30
Dar kilit (makaralı)
Narrow lock (roller)
D-876 (yerli) metalik
(native) metallic

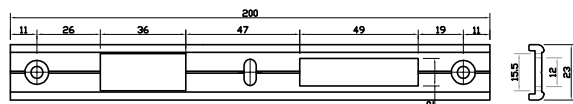

D-851 (yerli) naturel
D-852 (yerli) pres-renkli boyalı

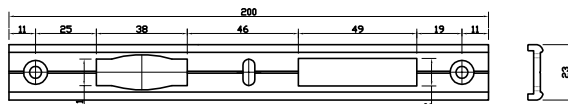

D-854 (yerli) naturel
D-855 (yerli) pres-renkli boyalı

kilit karşılığı
lock plate

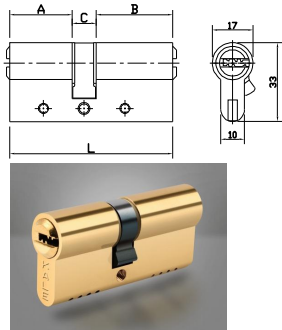

A	C	B	L	Barel Cylinders
26	10	26	62	D-878-1 (yerli) metalik
26	10	32	68	D-878-2 (yerli) metalik
30	10	40	80	D-878-3 (yerli) metalik
30	10	45	85	D-878-4 (yerli) metalik
30	10	50	90	D-878-5 (yerli) metalik
30	10	60	100	D-878-6 (yerli) metalik
25	10	65	100	D-878-7 (yerli) metalik
25	10	70	105	D-878-8 (yerli) metalik

Barel rozeti
Cylinder cover

	D-848-1	naturel eloksalli (mat anodized)
	D-848-2	pres veya renkli (mill finishand and painted)
	D-849-1	naturel eloksalli (mat anodized)
	D-849-2	pres veya renkli (mill finishand and painted)
	D-850-1	naturel eloksalli (mat anodized)
	D-850-2	pres veya renkli (mill finishand and painted)

