

Yalıtımlı Pencere ve Kapı Serisi Açılım Varyasyonları

Insulated Window and Door Serie Opening Variations

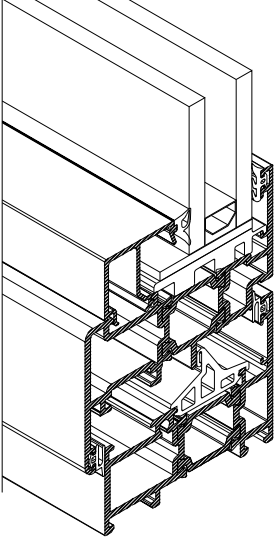

PENCERE SERİ
WINDOW SERIE

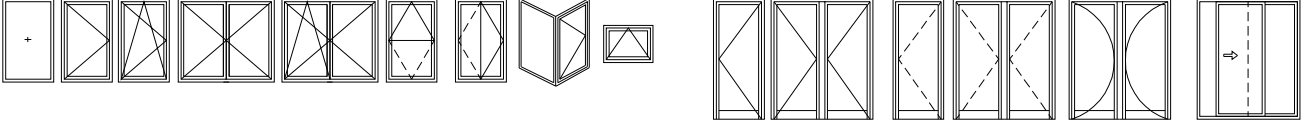
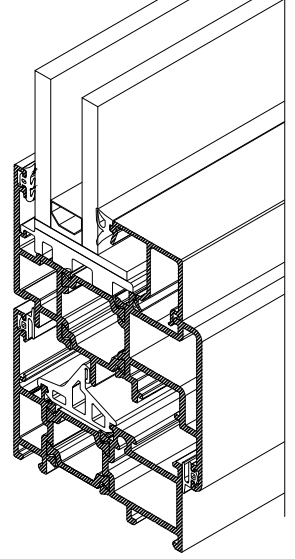

**PENCERE SERİ
(PVC AKSESUAR)**
WINDOW SERIE
(PVC ACCESSORIES)

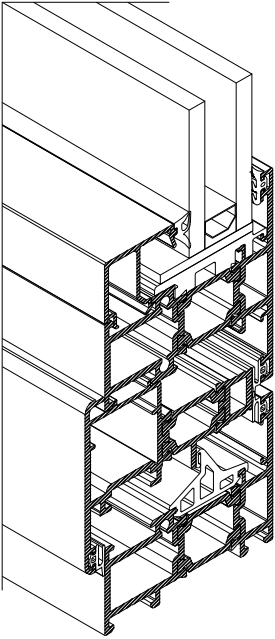

PIVOT SERİ
PIVOT SERIE

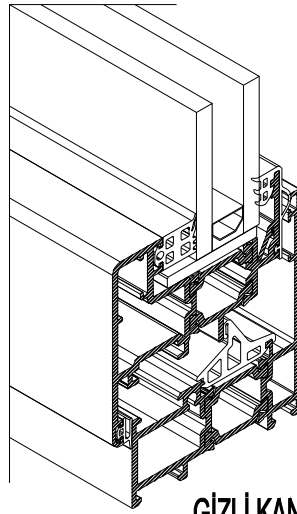

GİZLİ KANAT SERİ
HIDDEN CASEMENT SERIE

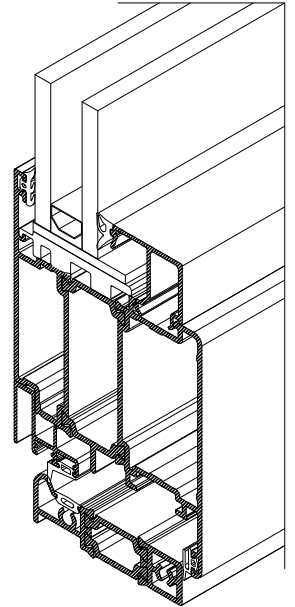

KAPI SERİ
DOOR SERIE

W6

W 65 - 2 T Yalıtımlı Pencere ve Kapı Serisi
W65-2T Insulated Window and Door Serie

Alaşım Özellikleri

Alloy Properties

EN AW 6060 (AlMgSi0,5 F22) EN AW 6063(AlMg0,7Si F22)







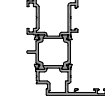

Üretim ve Mekanik Standartları

Production and Mecanical Standards

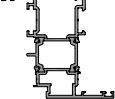
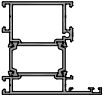
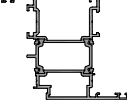
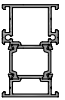
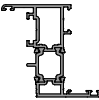
EN 12020-2 - EN 755-9 - EN 755-2

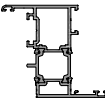
W6

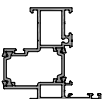
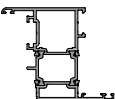
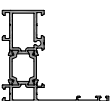
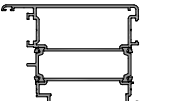
ÜRÜN TEKNİK ÖZELLİKLERİ PRODUCT'S TECHNICAL FEATURES

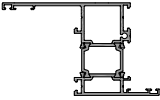
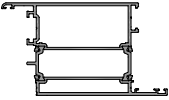
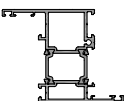
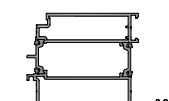
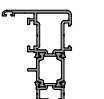
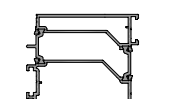









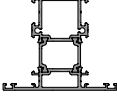

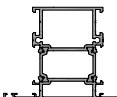

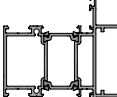

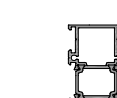

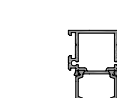
PROFİL KESİTİ PROFILE VIEW	PROFİL NO PROFILE NO	PROFİL AÇIKLAMASI PROFILE DESCRIPTION	gr/m	PROFİL KESİTİ PROFILE VIEW	PROFİL NO PROFILE NO	PROFİL AÇIKLAMASI PROFILE DESCRIPTION	gr/m
	W6-101 (49 - 29)	KASA PROFİLİ FRAME	PVC 1439		W6-218 (42 - 53)	PENCERE KANAT PROFİLİ CASEMENT PROFILE FOR WINDOW	PVC 1694
			POLYAMID 1424				POLYAMID 1678
	W6-102 (59 - 39)	KASA PROFİLİ FRAME	PVC 1655		W6-202 (47 - 58)	PENCERE KANAT PROFİLİ CASEMENT PROFILE FOR WINDOW	PVC 1808
			POLYAMID 1641				POLYAMID 1792
	W6-103 (69 - 49)	KASA PROFİLİ FRAME	PVC 1872		W6-203 (57 - 68)	PENCERE KANAT PROFİLİ CASEMENT PROFILE FOR WINDOW	PVC 2003
			POLYAMID 1858				POLYAMID 1987
	W6-104 (59 - 89)	TIRNAKSIZ KASA PR. FLAT FRAME PROFILE	PVC 1515		W6-216 (48 - 44)	PENCERE KANAT PROFİLİ CASEMENT PROFILE FOR WINDOW	PVC 1497
			POLYAMID 1500				POLYAMID 1481
	W6-105 (59 - 64)	TIRNAKSIZ KASA PR. FLAT FRAME PROFILE	PVC 1732		W6-219 (49 - 53)	PENCERE KANAT PROFİLİ CASEMENT PROFILE FOR WINDOW	PVC 1594
 İşaretili profil için satış temsilcinizden bilgi alınır.			POLYAMID 1717				POLYAMID 1578
	W6-106 (29 - 49)	CEPHE - PENCERE ADAPTÖRÜ FACADE - WINDOW ADAPTOR	PVC 1637		W6-217 (58 - 54)	PENCERE KANAT PROFİLİ CASEMENT PROFILE FOR WINDOW	PVC 1692
			POLYAMID 1623				POLYAMID 1676
	W6-107 (29 - 74)	PERVAZLI KASA PROFİLİ FRAME	PVC 1574		W6-204 (95 - 84)	İÇE AÇILIR KAPI KANADI INDOOR CASEMENT PROFILE FOR DOOR	PVC 2526
 İşaretili profil için satış temsilcinizden bilgi alınır.			POLYAMID 1559				POLYAMID 2510
	W6-108 (59 - 89)	PERVAZLI KASA PROFİLİ FRAME	PVC 1948		W6-205 (95 - 91)	İÇE AÇILIR KAPI KANADI INDOOR CASEMENT PROFILE FOR DOOR	PVC 2415
			POLYAMID 1933				POLYAMID 2399
	W6-109 (59 - 64)	PERVAZLI KASA PROFİLİ FRAME	PVC 1812		W6-206 (64 - 115)	DIŞA AÇILIR KAPI KANADI OUTDOOR CASEMENT PR. FOR DOOR	PVC 2568
			POLYAMID 1797				POLYAMID 2552
	W6-201 (37 - 48)	PENCERE KANAT PROFİLİ CASEMENT PROFILE FOR WINDOW	PVC 1601		W6-207 (71 - 115)	DIŞA AÇILIR KAPI KANADI OUTDOOR CASEMENT PR. FOR DOOR	PVC 2460
			POLYAMID 1585				POLYAMID 2444

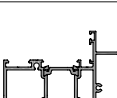
Profil değerleri teoriktir. Ağırlık olarak testimde yapılan tartım geçerlidir.
Profil imalatları TS EN 12020-2 ve TS EN 755-9 toleransı,
Moment değerleri EN 14024'e göre hesaplanmıştır.

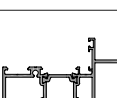
Profile values are theoretical pre-shipment weight will be valid.
The tolerances of Profile manufacturing are calculated according to EN 12020-2
and TS EN 755-9; moment values are calculated according to EN 14024.

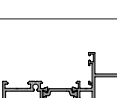
W6

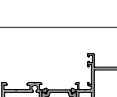
ÜRÜN TEKNİK ÖZELLİKLERİ PRODUCT'S TECHNICAL FEATURES

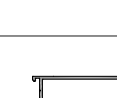
PROFİL KESİTİ PROFILE VIEW	PROFİL NO PROFILE NO	PROFİL AÇIKLAMASI PROFILE DESCRIPTION	gr/m	PROFİL KESİTİ PROFILE VIEW	PROFİL NO PROFILE NO	PROFİL AÇIKLAMASI PROFILE DESCRIPTION	gr/m
	W6-208 (60.9 - 19.2)	GİZLİ KANAT PROFİLİ HIDDEN CASEMENT PROFILE	PVC 1465		W6-302 (79 - 39)	ORTA KAYIT PROFİLİ TRANSOM PROFILE	PVC 1812
POLYAMID 1449			POLYAMID 1798				
	W6-209 (53.6 - 42.6)	PENCERE KANAT PROFİLİ CASEMENT PROFILE FOR WINDOW	PVC 1770		W6-303 (89 - 49)	ORTA KAYIT PROFİLİ TRANSOM PROFILE	PVC 2029
POLYAMID 1754			POLYAMID 2014				
	W6-210 (63.6 - 52.6)	PENCERE KANAT PROFİLİ CASEMENT PROFILE FOR WINDOW	PVC 1965		W6-304 (69 - 29)	TAKVİYELİ ORTA KAYIT REINFORCED TRANSOM PROFILE	PVC 2823
POLYAMID 1949			POLYAMID 2808				
	W6-211 (100.6 - 89.6)	İÇE AÇILIR KAPI KANADI INDOOR CASEMENT PROFILE FOR DOOR	PVC 2679		W6-305 (104 - 39)	KASA PROFİLİ FRAME	PVC 1948
POLYAMID 2663			POLYAMID 1933				
	W6-212 (50 - 101)	DIŞA AÇILIR KAPI KANADI OUTDOOR CASEMENT PR. FOR DOOR	PVC 2298		W6-306 (129 - 39)	KASA PROFİLİ FRAME	PVC 2083
POLYAMID 2282			POLYAMID 2069				
	W6-213 (81 - 70)	İÇE AÇILIR KAPI KANADI INDOOR CASEMENT PROFILE FOR DOOR	PVC 2240		W6-307 (69 - 29)	TAKVİYELİ ORTA KAYIT REINFORCED TRANSOM PROFILE	PVC 2534
POLYAMID 2224			POLYAMID 2520				
	W6-214 (81 - 77)	İÇE AÇILIR KAPI KANADI INDOOR CASEMENT PROFILE FOR DOOR	PVC 2137		W6-308-b (74 - 92)	TAKVİYELİ OVAL ORTAKAYIT RAINFORCED OVAL TRANSOM	PVC 2321
POLYAMID 2121			POLYAMID 2306				
	W6-215 (57 - 101)	DIŞA AÇILIR KAPI KANADI OUTDOOR CASEMENT PR. FOR DOOR	PVC 2187		W6-308-a (74 - 103)	TAKVİYELİ OVAL ORTAKAYIT RAINFORCED OVAL TRANSOM	PVC 2440
POLYAMID 2171			POLYAMID 2425				
	W6-301 (69 - 29)	ORTA KAYIT PROFİLİ TRANSOM PROFILE	PVC 1595		W6-308-c (74 - 137)	TAKVİYELİ OVAL ORTAKAYIT RAINFORCED OVAL TRANSOM	PVC 2938
POLYAMID 1581			POLYAMID 2923				
	W6-308 (74 - 34)	ORTA KAYIT PROFİLİ TRANSOM PROFILE	PVC 1704		W6-401 (110 - 70)	ETEK-ORTA KAYIT PROFİLİ PLINTH-TRANSOM PROFILE	PVC 2484
POLYAMID 1689			POLYAMID 2470				

Profil değerleri teoriktir. Ağırlık olarak testimde yapılan tartım geçerlidir.
Profil imalatları TS EN 12020-2 ve TS EN 755-9 toleransı,
Moment değerleri EN 14024'e göre hesaplanmıştır.

Profile values are theoretical pre-shipment weight will be valid.
The tolerances of Profile manufacturing are calculated according to EN 12020-2
and TS EN 755-9; moment values are calculated according to EN 14024.

W6

ÜRÜN TEKNİK ÖZELLİKLERİ PRODUCT'S TECHNICAL FEATURES























PROFİL KESİTİ PROFILE VIEW	PROFİL NO PROFILE NO	PROFİL AÇIKLAMASI PROFILE DESCRIPTION	gr/m	PROFİL KESİTİ PROFILE VIEW	PROFİL NO PROFILE NO	PROFİL AÇIKLAMASI PROFILE DESCRIPTION	gr/m
	W6-403 (140 - 120)	ETEK-ORTA KAYIT PROFİLİ PLINTH-TRANSOM PROFILE	PVC 3219 POLYAMID 3204		W-521 (124 - 10)	LAMBİRİ PROFİLİ WAINSCOT PROFILE	805
	W6-402 (170 - 150)	ETEK PROFİLİ PLINTH PROFILE	PVC 3869 POLYAMID 3855		W-522 (88 - 10)	LAMBİRİ PROFİLİ WAINSCOT PROFILE	519
 ⚠ İşaretili profil için satış temsilcinizden bilgi alınır.	W5-550 (66.3 - 66.3)	90 KÖŞE PROFİLİ 90 CORNER PROFILE	PVC 1614 POLYAMID 1599		W-523 (45 - 75.8)	MENFEZ PROFİLİ CULVERT PROFILE	647
 ⚠ İşaretili profil için satış temsilcinizden bilgi alınır.	W5-551 (124.4 - 82.6)	45 KÖŞE PROFİLİ 45 CORNER PROFILE	PVC 2426 POLYAMID 2416		W-524 (105 - 1.6)	DENİZLİK PROFİLİ CULVERT PROFILE	639
	W-503 (29.3 - 20.1)	DAMLALIK PROFİLİ WEATHERDIP PROFILE	211		W-525 (105 - 1.8)	DENİZLİK PROFİLİ CULVERT PROFILE	714
 ⚠ İşaretili profil için satış temsilcinizden bilgi alınır.	W-506 (31.9 - 29)	PANJUR PROFİLİ SHUTTER PROFILE	363		W-526 (160.61 - 1.8)	DENİZLİK PROFİLİ CULVERT PROFILE	1066
 ⚠ İşaretili profil için satış temsilcinizden bilgi alınır.	W-507 (44 - 55)	PANJUR DÜŞEY PROFİLİ SHUTTER VERTICAL PROFILE	834		W-527 (160.61 - 2)	DENİZLİK PROFİLİ CULVERT PROFILE	1181
	W1-508 (4.2 - 19)	TIJ PROFİLİ PUSHING ROD PROFILE	138	 dış rekşsiz not to scale	W-528 (206.58 - 1.9)	DENİZLİK PROFİLİ CULVERT PROFILE	1367
	W-509 (95 - 4)	LAMBİRİ PROFİLİ WAINSCOT PROFILE	319	 dış rekşsiz not to scale	W-529 (206.58 - 2.2)	DENİZLİK PROFİLİ CULVERT PROFILE	1577
	W-510 (4.3 - 92.7)	LAMBİRİ PROFİLİ WAINSCOT PROFILE	342		W-530 (150 - 2)	DENİZLİK PROFİLİ CULVERT PROFILE	1209

Profil değerleri teoriktir. Ağırlık olarak testimde yapılan tartım geçerlidir.
Profil imalatları TS EN 12020-2 ve TS EN 755-9 toleransı,
Moment değerleri EN 14024'e göre hesaplanmıştır.

Profile values are theoretical pre-shipment weight will be valid.
The tolerances of Profile manufacturing are calculated according to EN 12020-2
and TS EN 755-9; moment values are calculated according to EN 14024.

W6

ÜRÜN TEKNİK ÖZELLİKLERİ PRODUCT'S TECHNICAL FEATURES

PROFİL KESİTİ PROFILE VIEW	PROFİL NO PROFILE NO	PROFİL AÇIKLAMASI PROFILE DESCRIPTION	gr/m	PROFİL KESİTİ PROFILE VIEW	PROFİL NO PROFILE NO	PROFİL AÇIKLAMASI PROFILE DESCRIPTION	gr/m
	W-511 (3.5 - 24.5)	CAM ÇİTASI GLASS BEAM	187		W-512-a (7.5 - 24.5)	CAM ÇİTASI GLASS BEAM	194
	W-512 (7.5 - 24.5)	CAM ÇİTASI GLASS BEAM	206		W-513-a (11.5 - 24.4)	CAM ÇİTASI GLASS BEAM	216
	W-513 (11.5 - 24.5)	CAM ÇİTASI GLASS BEAM	227		W-514-a (15.5 - 24.4)	CAM ÇİTASI GLASS BEAM	228
	W-514 (15.5 - 24.5)	CAM ÇİTASI GLASS BEAM	252		W-515-a (19.5 - 24.4)	CAM ÇİTASI GLASS BEAM	242
	W-515 (19.5 - 24.5)	CAM ÇİTASI GLASS BEAM	273		W-516-a (23.5 - 24.4)	CAM ÇİTASI GLASS BEAM	270
	W-516 (23.5 - 24.5)	CAM ÇİTASI GLASS BEAM	286		W-517-a (27.5 - 24.4)	CAM ÇİTASI GLASS BEAM	284
	W-517 (27.5 - 24.5)	CAM ÇİTASI GLASS BEAM	299		W-518-a (31.5 - 24.4)	CAM ÇİTASI GLASS BEAM	297
	W-518 (31.5 - 24.5)	CAM ÇİTASI GLASS BEAM	316		W-519-a (35.5 - 24.4)	CAM ÇİTASI GLASS BEAM	316
	W-519 (35.5 - 24.5)	CAM ÇİTASI GLASS BEAM	336		W-520-a (39.5 - 24.4)	CAM ÇİTASI GLASS BEAM	330
	W-520 (39.5 - 24.5)	CAM ÇİTASI GLASS BEAM	351		W-521-a (43.5 - 24.4)	CAM ÇİTASI GLASS BEAM	344
	W-511-a (3.5 - 24.4)	CAM ÇİTASI GLASS BEAM	193		W-522-a (29.5 - 24.4)	CAM ÇİTASI GLASS BEAM	278

⚠ İşaretti profil için satış temsilcinizden bilgi alınız.

Profil değerleri teoriktir. Ağırlık olarak testimde yapılan tartım geçerlidir.
Profil imalatları TS EN 12020-2 ve TS EN 755-9 toleransı,
Moment değerleri EN 14024'e göre hesaplanmıştır.

Profile values are theoretical pre-shipment weight will be valid.
The tolerances of Profile manufacturing are calculated according to EN 12020-2
and TS EN 755-9; moment values are calculated according to EN 14024.

W6

ÜRÜN TEKNİK ÖZELLİKLERİ PRODUCT'S TECHNICAL FEATURES











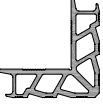

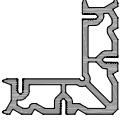

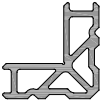
PROFİL KESİTİ PROFILE VIEW	PROFİL NO PROFILE NO	PROFİL AÇIKLAMASI PROFILE DESCRIPTION	gr/m	PROFİL KESİTİ PROFILE VIEW	PROFİL NO PROFILE NO	PROFİL AÇIKLAMASI PROFILE DESCRIPTION	gr/m
	W-512-B (7.5 - 24.2)	CAM ÇITASI GLASS BEAM	227		W-541 (28 - 26.7)	BİNİ PROFİLİ INTERLOCKING PROFILE	219
	W-531 (170 - 2)	DENİZLİK PROFİLİ CULVERT PROFILE	1322		W-542 (48.5 - 26.3)	BİNİ PROFİLİ INTERLOCKING PROFILE	306
	W-532 (190 - 2.2)	DENİZLİK PROFİLİ CULVERT PROFILE	1573		W-548 (52.6 - 41.4)	BİNİ PROFİLİ INTERLOCKING PROFILE	424
	W-533 (210 - 2.2)	DENİZLİK PROFİLİ CULVERT PROFILE	1696		W-543 (20 - 22.1)	KASA ADAPTÖRÜ FRAME ADAPTER	213
	W-535 (40 - 26.5)	BİNİ PROFİLİ INTERLOCKING PROFILE	229		W-544 (88 - 10)	EŞİK PROFİLİ THRESHOLD PROFILE	728
	W-536 (40 - 26)	BİNİ PROFİLİ INTERLOCKING PROFILE	292		W-545 (62.3 - 12)	EŞİK PROFİLİ THRESHOLD PROFILE	578
	W-537 (25 - 26)	BİNİ PROFİLİ INTERLOCKING PROFILE	226		SC0308 (70 - 70)	KÖŞE BİRLEŞTİRME CORNER CLEATS	2392
	W-538 (25 - 25)	BİNİ PROFİLİ INTERLOCKING PROFILE	249		W-601 (74 - 74) 14.6mm	KÖŞE BİRLEŞTİRME CORNER CLEATS	3428
	W-539 (45 - 35)	BİNİ PROFİLİ INTERLOCKING PROFILE	460		W-611 (70 - 70) 14.6mm	KÖŞE BİRLEŞTİRME CORNER CLEATS	2520
	W-540 (20.6 - 40.4)	BİNİ PROFİLİ INTERLOCKING PROFILE	208		W-601\2 (80 - 80)	KÖŞE BİRLEŞTİRME CORNER CLEATS	4285

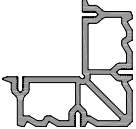
Profil değerleri teoriktir. Ağırlık olarak testimde yapılan tartım geçerlidir.
Profil imalatları TS EN 12020-2 ve TS EN 755-9 toleransı,
Moment değerleri EN 14024'e göre hesaplanmıştır.

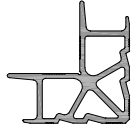
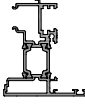
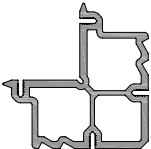
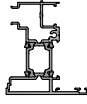
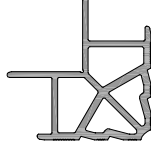
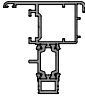
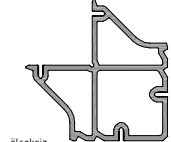
Profile values are theoretical pre-shipment weight will be valid.
The tolerances of Profile manufacturing are calculated according to EN 12020-2
and TS EN 755-9; moment values are calculated according to EN 14024.

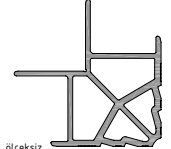
W6

ÜRÜN TEKNİK ÖZELLİKLERİ PRODUCT'S TECHNICAL FEATURES

PROFİL KESİTİ PROFILE VIEW	PROFİL NO PROFILE NO	PROFİL AÇIKLAMASI PROFILE DESCRIPTION	gr/m	PROFİL KESİTİ PROFILE VIEW	PROFİL NO PROFILE NO	PROFİL AÇIKLAMASI PROFILE DESCRIPTION	gr/m
	W-611\2 (70 - 70) 19.6mm	KÖŞE BİRLEŞTİRME CORNER CLEATS	2749		W-607 (8.2 - 36.8)	ORTA KAYIT BİRLEŞTİRME CORNER CLEATS FOR TRANSOM	431
	W-602 (80 - 80) 24.6mm	KÖŞE BİRLEŞTİRME CORNER CLEATS	4380		W-608 (24.1 - 39)	ORTA KAYIT BİRLEŞTİRME CORNER CLEATS FOR TRANSOM	583
	W-612 (67 - 67) 29.6mm	KÖŞE BİRLEŞTİRME CORNER CLEATS	3524		W4-504 (17.3 - 25)	ETEK ADAPTÖRÜ PLINTH ADAPTER	227
	W-603 (90 - 90) 34.6mm	KÖŞE BİRLEŞTİRME CORNER CLEATS	4871		W4-505 (12.8 - 25)	ETEK ADAPTÖRÜ PLINTH ADAPTER	184
	W-613 (85 - 85) 34.6mm	KÖŞE BİRLEŞTİRME CORNER CLEATS	3945		W6-501 (57 - 58.4)	AÇILIM ADAPTÖRÜ OPENING ADAPTER	PVC 1448 POLYAMID 1433
	W-604 (101 - 47.6) 47.6mm	KÖŞE BİRLEŞTİRME CORNER CLEATS	5539		W6-501-a (57 - 58.4)	AÇILIM ADAPTÖRÜ OPENING ADAPTER	PVC 1424 POLYAMID 1409
	W-614 (100 - 100) 47.6mm	KÖŞE BİRLEŞTİRME CORNER CLEATS	5318		W6-504 (13.8 - 57)	PİVOT ADAPT. PROFİLİ PIVOT ADAPT. PROFILE	PVC 1291 POLYAMID 1275
	W-605 (116 - 61.6) 61.6mm	KÖŞE BİRLEŞTİRME CORNER CLEATS	6063		W6-506 (30.3 - 55)	AÇILIM ADAPTÖRÜ OPENING ADAPTER	PVC 844 POLYAMID 829
	W-615 (120.2 - 120.2) 61.6mm	KÖŞE BİRLEŞTİRME CORNER CLEATS	6313		W3-508 (26.2 - 31)	ETEK ADAPTÖRÜ PLINTH ADAPTER	330
	W-606 (23.6 - 39.2)	ORTA KAYIT BİRLEŞTİRME CORNER CLEATS FOR TRANSOM	482		W3-509 (24.7 - 24)	ETEK ADAPTÖRÜ PLINTH ADAPTER	271













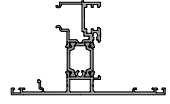

⚠ İşaretti profil için satış temsilcinizden bilgi alınır.

Profil değerleri teoriktir. Ağırlık olarak testimde yapılan tartım geçerlidir.
Profil imalatları TS EN 12020-2 ve TS EN 755-9 toleransı,
Moment değerleri EN 14024'e göre hesaplanmıştır.

Profile values are theoretical pre-shipment weight will be valid.
The tolerances of Profile manufacturing are calculated according to EN 12020-2
and TS EN 755-9; moment values are calculated according to EN 14024.

W6

ÜRÜN TEKNİK ÖZELLİKLERİ PRODUCT'S TECHNICAL FEATURES

PROFİL KESİTİ PROFILE VIEW	PROFİL NO PROFILE NO	PROFİL AÇIKLAMASI PROFILE DESCRIPTION	gr/m	PROFİL KESİTİ PROFILE VIEW	PROFİL NO PROFILE NO	PROFİL AÇIKLAMASI PROFILE DESCRIPTION	gr/m
	W6-510 (47 - 65)	AÇILIM ADAPTÖRÜ OPENING ADAPTER	PVC 1262 POLYAMID 1248		SC0307 (55 - 55)	KÖŞE BİRLEŞTİRME CORNER CLEATS	2140
  İşaretili profil için satış temsilcinizden bilgi alınır.	W3-511 (16 - 57.4)	CEPHE BAĞLANTI PROFİLİ CONNECTION PROFILE FOR FACADE	496		SC0309 (55 - 55)	KÖŞE BİRLEŞTİRME CORNER CLEATS	1636
	W6-512 (107 - 31)	ÇİFT KANAT ADAPTÖRÜ CASEMENT PROFILE ADAPTOR	PVC 1732 POLYAMID 1718		W-608\2 (23.6-39.5)	ORTA KAYIT BİRLEŞTİRME CORNER CLEATS FOR TRANSOM	904
	W6-513 (12.8 - 25)	SAKLI KANAT SABİT ADAPT. HIDDEN CASEMENT PROFILE ADAPT.	PVC 959 POLYAMID 944		W4-508 (17.3 - 55)	PERVAZ ADAPTÖRÜ FRAME ADAPTER	356
	W65-555 (17 - 56.7)	EŞİK PROFİLİ THRESHOLD PROFILE	PVC 824 POLYAMID 810				
	W-557 (24.5 - 20.5)	ETEK ADAPTÖRÜ PLINTH ADAPTER	260				
	W-558 (37.6 - 20)	ETEK ADAPTÖRÜ PLINTH ADAPTER	173				
	W-559 (37.6 - 20)	ETEK ADAPTÖRÜ PLINTH ADAPTER	216				
	W3-507 (8.2 - 26)	SAKLI KANAT CAM ÇİTASI GLASS SKIRTING FOR HIDDEN CASEM.	155				
	W-534 (40 - 26.5)	BİNİ PROFİLİ INTERLOCKING PROFILE	328				

Profil değerleri teoriktir. Ağırlık olarak testimde yapılan tartım geçerlidir.
Profil imalatları TS EN 12020-2 ve TS EN 755-9 toleransı,
Moment değerleri EN 14024'e göre hesaplanmıştır.

Profile values are theoretical pre-shipment weight will be valid.
The tolerances of Profile manufacturing are calculated according to EN 12020-2
and TS EN 755-9; moment values are calculated according to EN 14024.

W6
W 65-2 T YALITIMLI SERİ PROFİLLERİ
W65-2 T INSULATED SERIES

ÜRÜN TEKNİK ÖZELLİKLERİ
PRODUCT'S TECHNICAL FEATURES

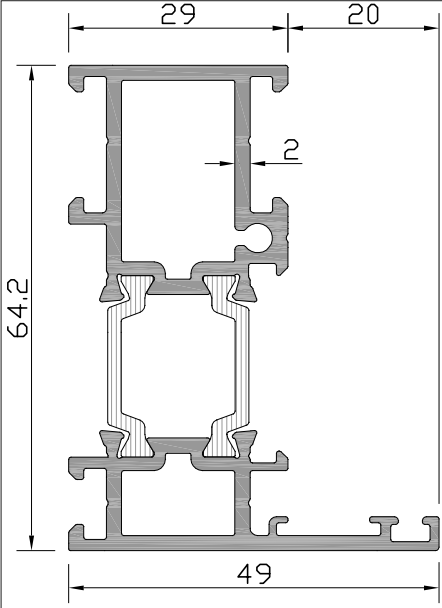

Profil No: W6-101

Ağırlık PVC	: 1439	gr/m
Ağırlık POLY	: 1424	gr/m
lx	: 18,40	cm ⁴
ly	: 5,75	cm ⁴

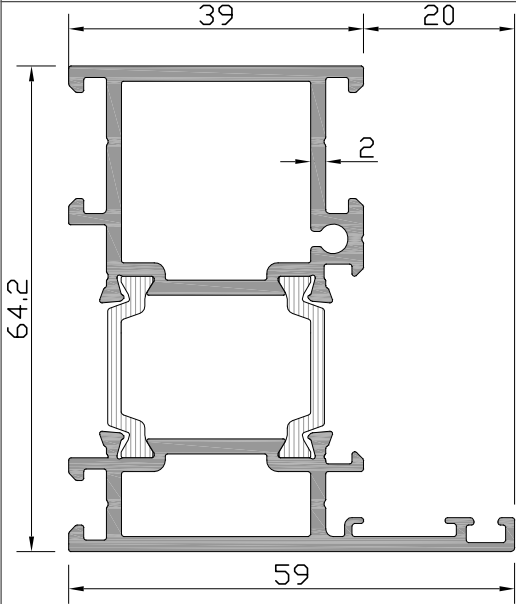
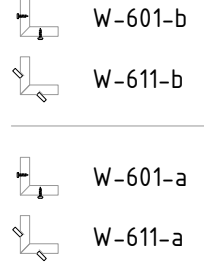

Profil No: W6-102

Ağırlık PVC	: 1655	gr/m
Ağırlık POLY	: 1641	gr/m
lx	: 21,80	cm ⁴
ly	: 11,34	cm ⁴

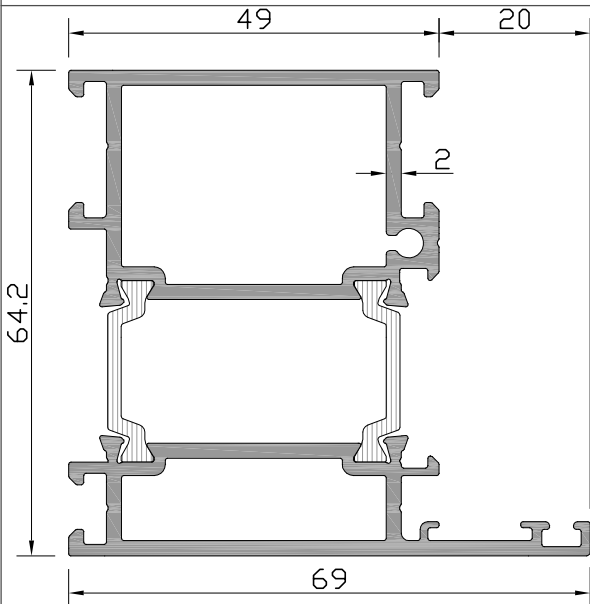
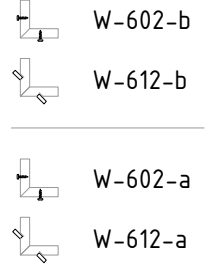

Profil No: W6-103

Ağırlık PVC	: 1872	gr/m
Ağırlık POLY	: 1858	gr/m
lx	: 25,20	cm ⁴
ly	: 19,66	cm ⁴

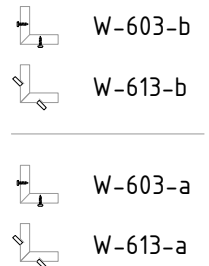

W6
W 65-2 T YALITIMLI SERİ PROFİLLERİ
W65-2 T INSULATED SERIES

ÜRÜN TEKNİK ÖZELLİKLERİ
PRODUCT'S TECHNICAL FEATURES

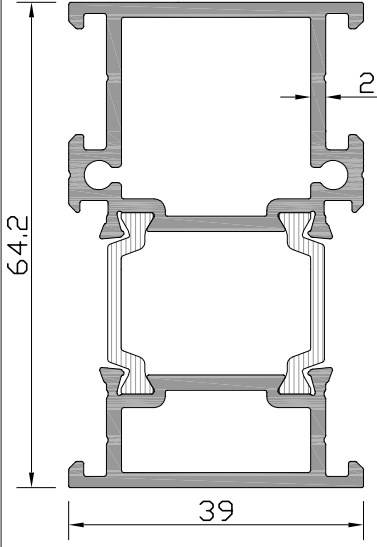

Profil No: W6-104

Ağırlık PVC	: 1515	gr/m
Ağırlık POLY	: 1500	gr/m
lx	: 18,60	cm ⁴
ly	: 7,55	cm ⁴

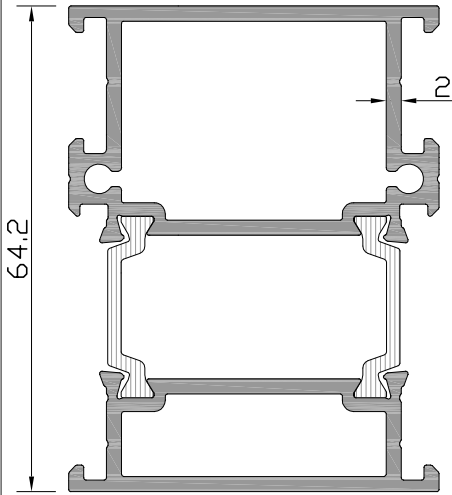
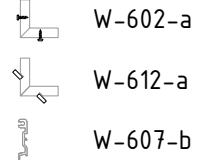
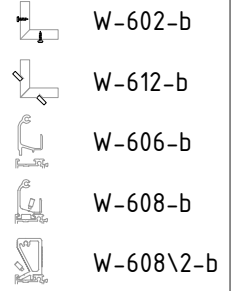

Profil No: W6-105 ⚠

Ağırlık PVC	: 1732	gr/m
Ağırlık POLY	: 1717	gr/m
lx	: 22,08	cm ⁴
ly	: 14,41	cm ⁴

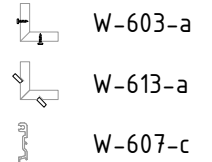
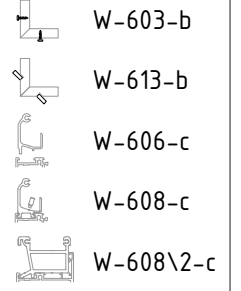

⚠ İşareti profil için satış temsilcinizden bilgi alınız.

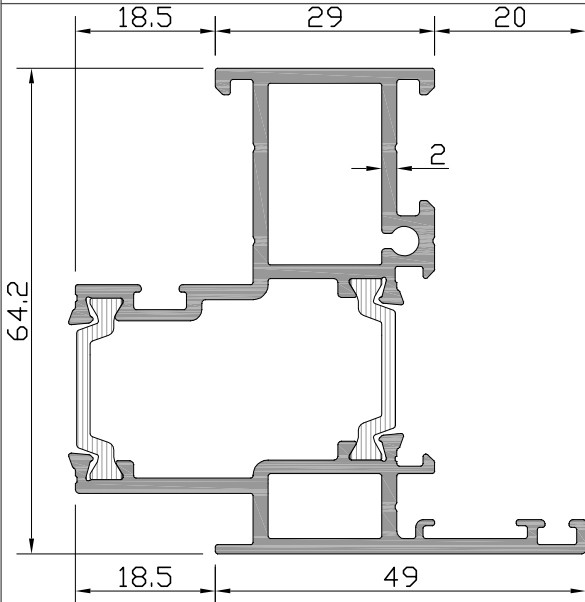

Profil No: W6-106

Ağırlık PVC	: 1637	gr/m
Ağırlık POLY	: 1623	gr/m
lx	: 19,47	cm ⁴
ly	: 12,14	cm ⁴

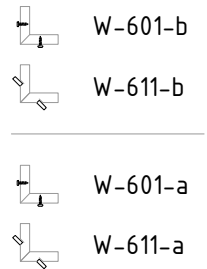

W6
W 65-2 T YALITIMLI SERİ PROFİLLERİ
W65-2 T INSULATED SERIES

ÜRÜN TEKNİK ÖZELLİKLERİ
PRODUCT'S TECHNICAL FEATURES

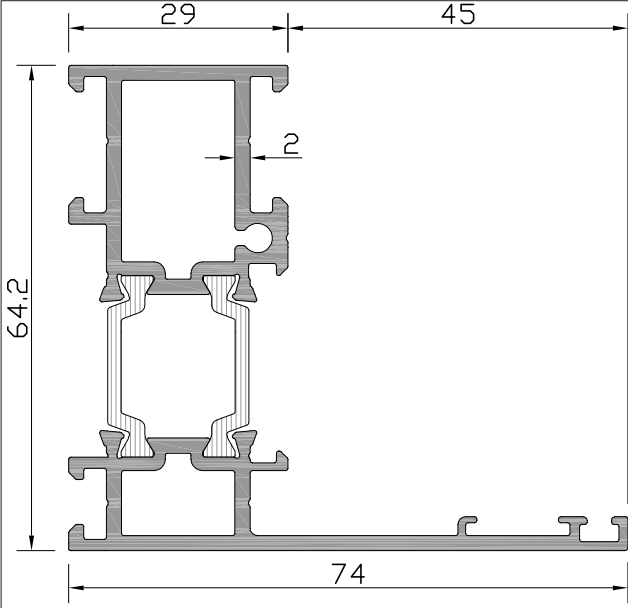

Profil No: **W6-107** ⚠

Ağırlık PVC	: 1574	gr/m
Ağırlık POLY	: 1559	gr/m
lx	: 20,90	cm ⁴
ly	: 15,44	cm ⁴

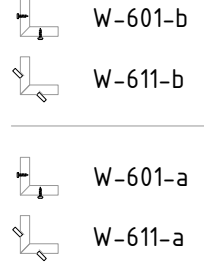

⚠ İşaretti profil için satış temsilcinizden bilgi alınız.

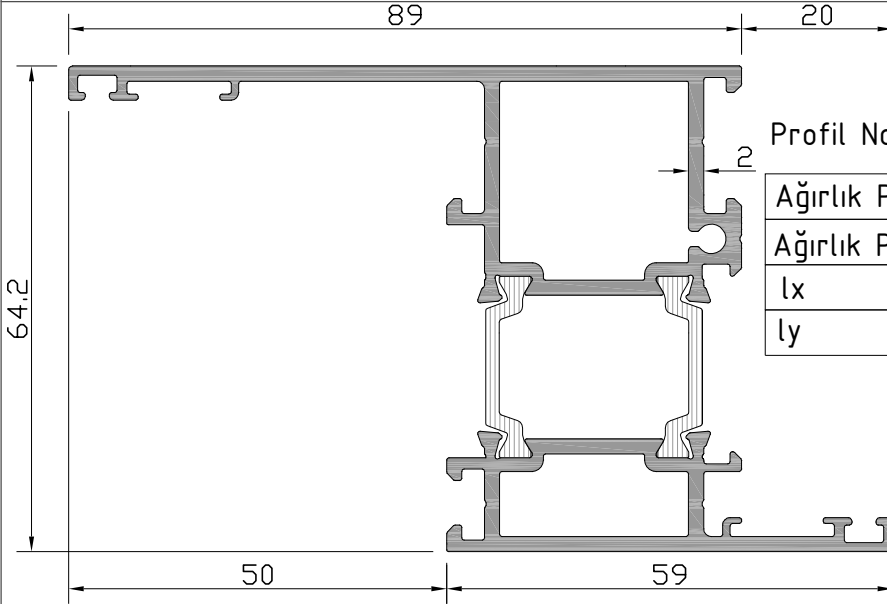

Profil No: **W6-108**

Ağırlık PVC	: 1948	gr/m
Ağırlık POLY	: 1933	gr/m
lx	: 29,62	cm ⁴
ly	: 33,63	cm ⁴

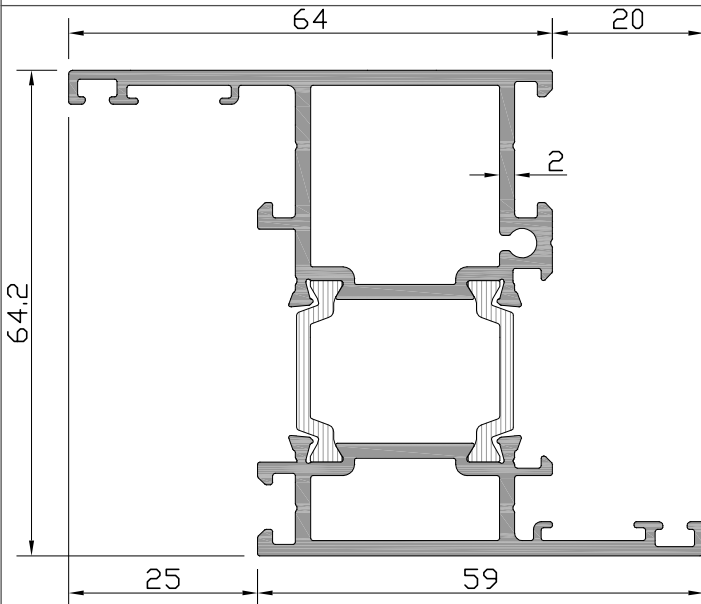
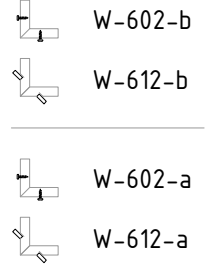

Profil No: **W6-109**

Ağırlık PVC	: 1812	gr/m
Ağırlık POLY	: 1797	gr/m
lx	: 26,30	cm ⁴
ly	: 17,78	cm ⁴

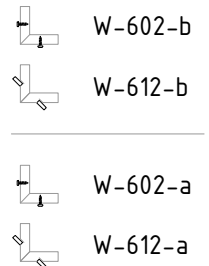

W6
W 65-2 T YALITIMLI SERİ PROFİLLERİ
W65-2 T INSULATED SERIES

ÜRÜN TEKNİK ÖZELLİKLERİ
PRODUCT'S TECHNICAL FEATURES

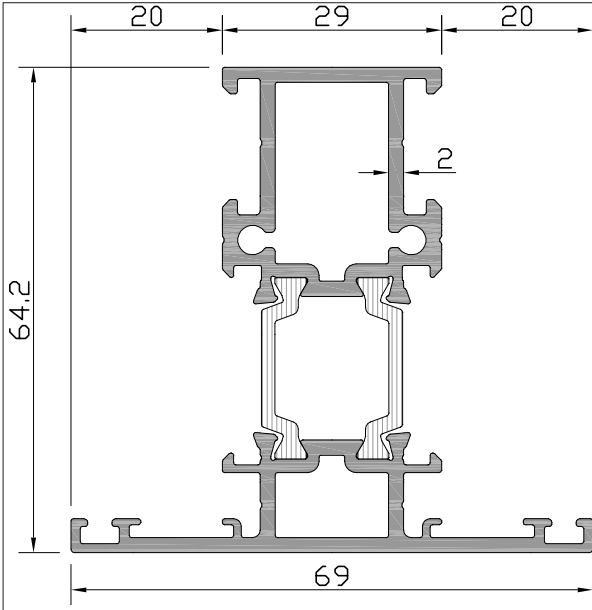

Profil No: W6-301

Ağırlık PVC	: 1595	gr/m
Ağırlık POLY	: 1581	gr/m
lx	: 20,84	cm ⁴
ly	: 9,43	cm ⁴

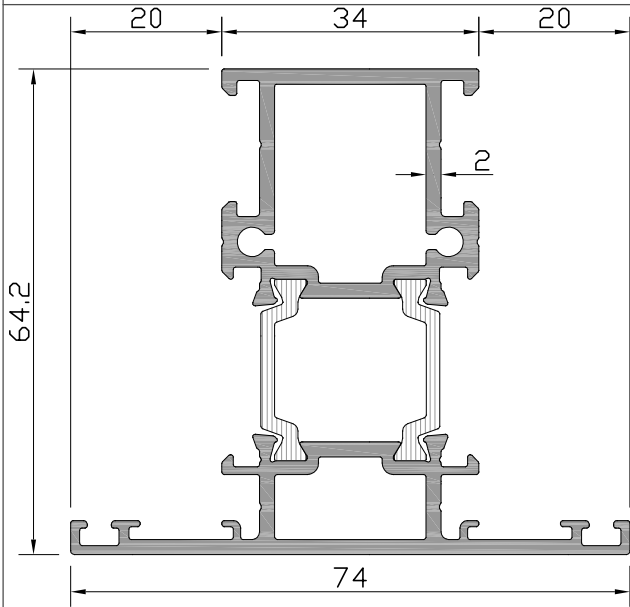
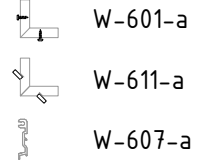
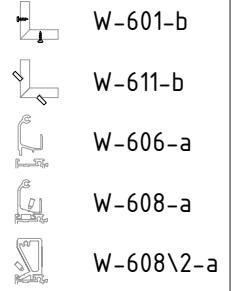

Profil No: W6-308

Ağırlık PVC	: 1704	gr/m
Ağırlık POLY	: 1689	gr/m
lx	: 22,55	cm ⁴
ly	: 12,65	cm ⁴

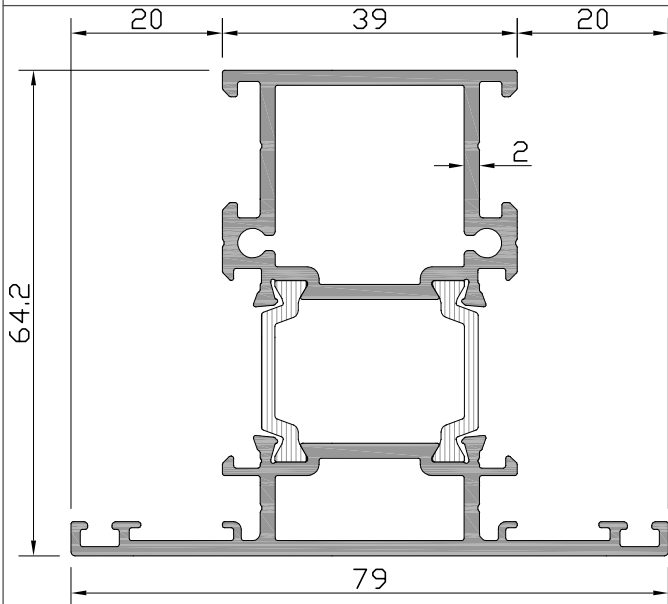
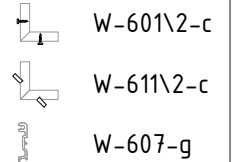
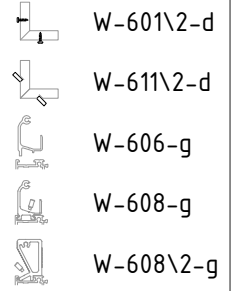

Profil No: W6-302

Ağırlık PVC	: 1812	gr/m
Ağırlık POLY	: 1798	gr/m
lx	: 24,26	cm ⁴
ly	: 16,59	cm ⁴

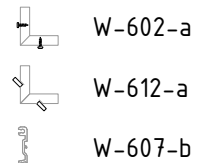
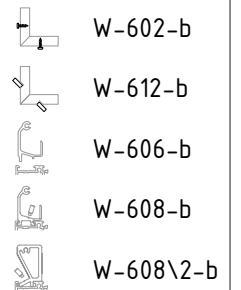

W6
W 65-2 T YALITIMLI SERİ PROFİLLERİ
W65-2 T INSULATED SERIES

ÜRÜN TEKNİK ÖZELLİKLERİ
PRODUCT'S TECHNICAL FEATURES

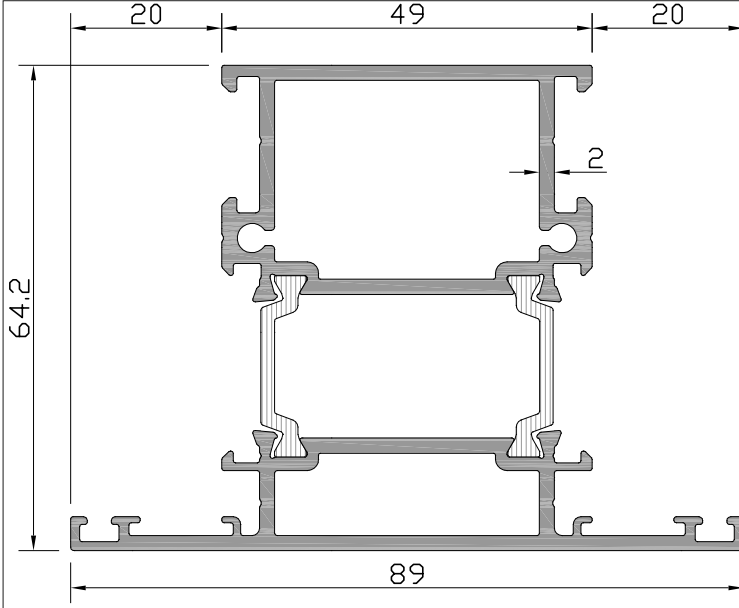

Profil No: W6-303

Ağırlık PVC	: 2029	gr/m
Ağırlık POLY	: 2014	gr/m
lx	: 27,65	cm ⁴
ly	: 26,76	cm ⁴

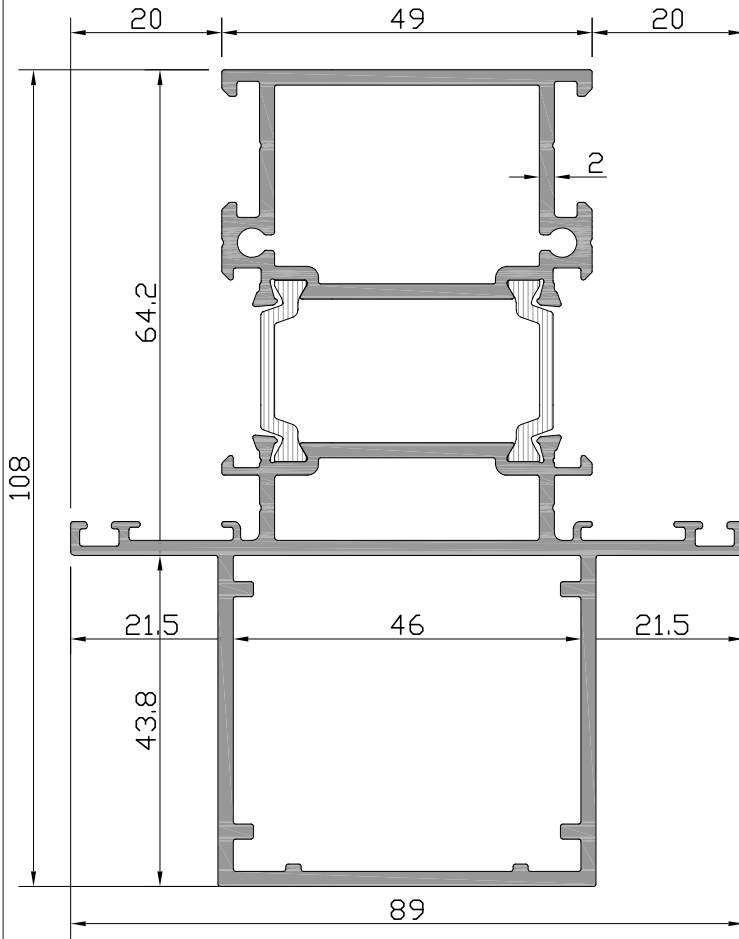
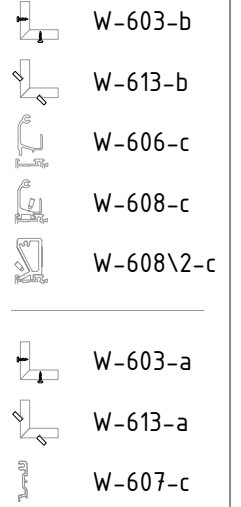

Profil No: W6-304



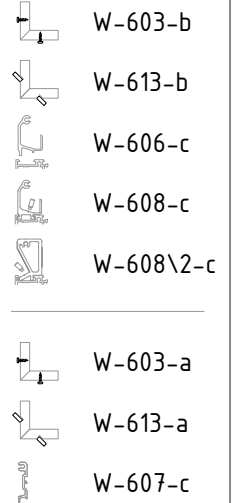



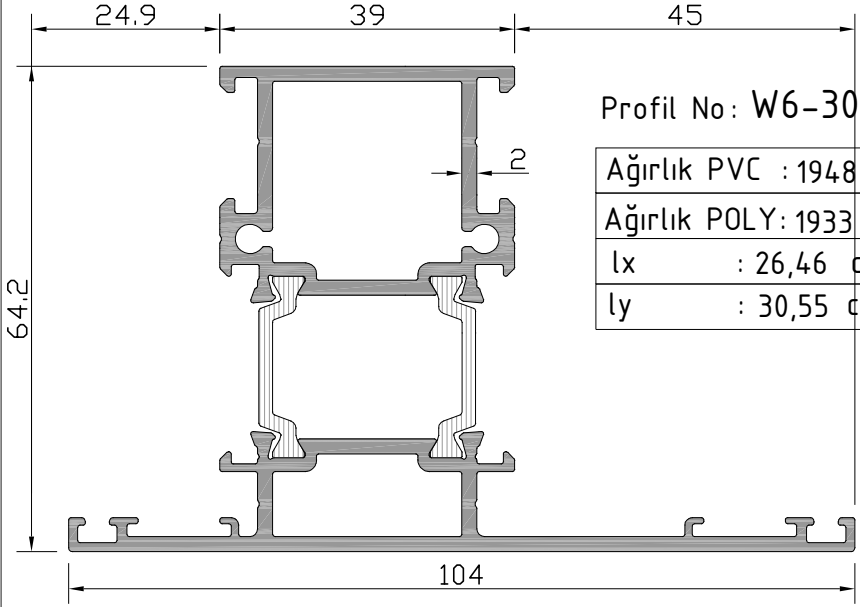

Ağırlık PVC	: 2823	gr/m
Ağırlık POLY	: 2808	gr/m
lx	: 84,01	cm ⁴
ly	: 39,59	cm ⁴









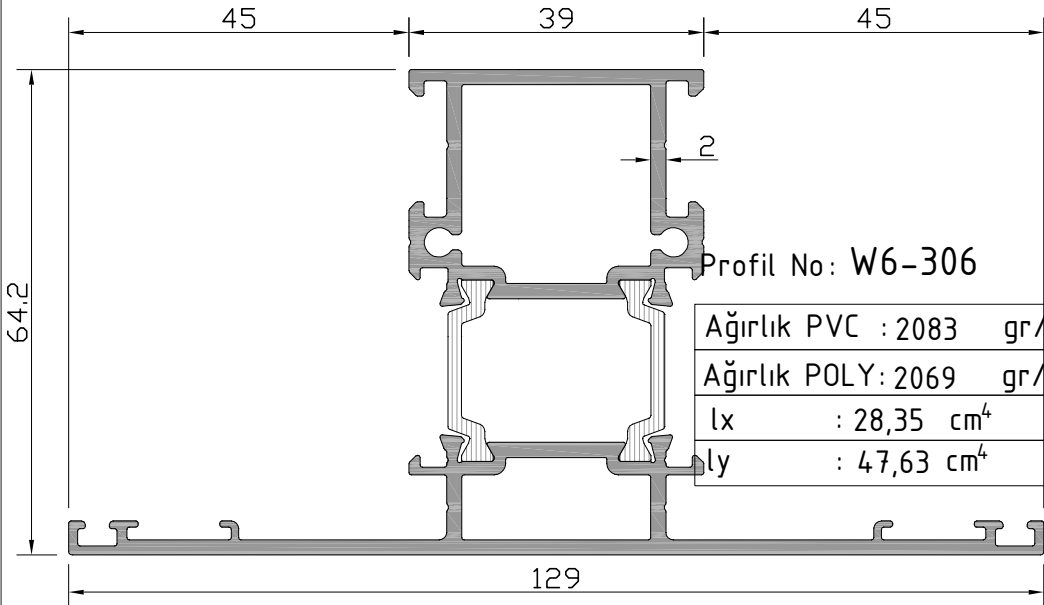

W6
W 65-2 T YALITIMLI SERİ PROFİLLERİ
W65-2 T INSULATED SERIES

ÜRÜN TEKNİK ÖZELLİKLERİ
PRODUCT'S TECHNICAL FEATURES



-  W-602-b
-  W-612-b
-  W-606-b
-  W-608-b
-  W-608\2-b
-  W-602-a
-  W-612-a
-  W-607-b



-  W-602-b
-  W-612-b
-  W-606-b
-  W-608-b
-  W-608\2-b
-  W-602-a
-  W-612-a
-  W-607-b





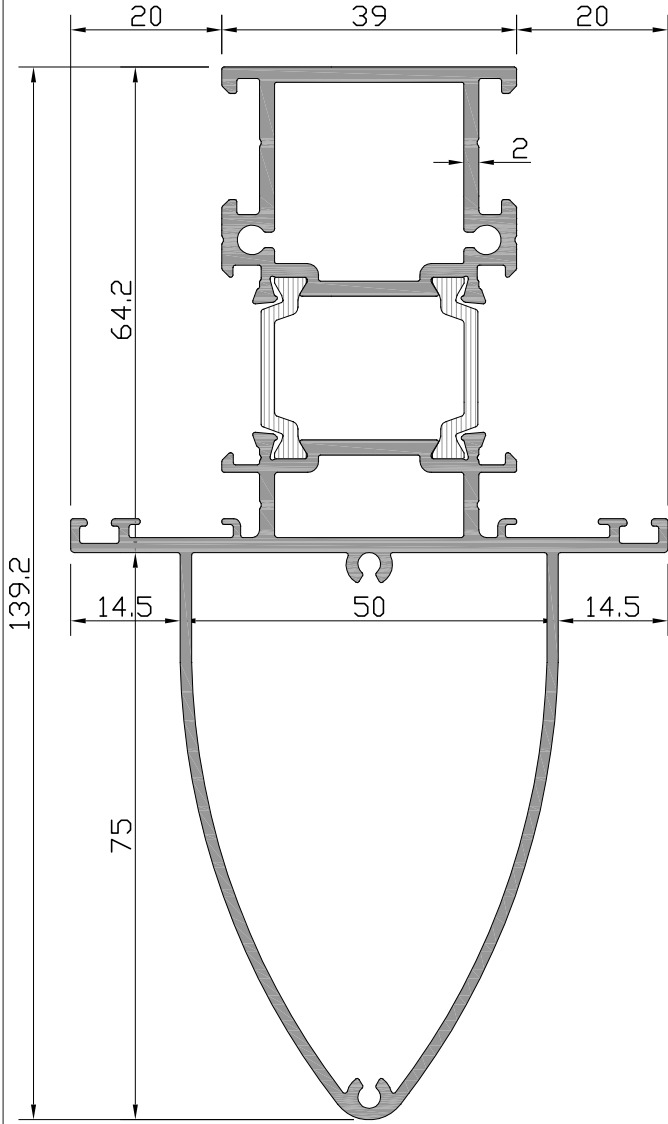



W6
W 65-2 T YALITIMLI SERİ PROFİLLERİ
W65-2 T INSULATED SERIES

ÜRÜN TEKNİK ÖZELLİKLERİ
PRODUCT'S TECHNICAL FEATURES



Profil No: W6-307

Ağırlık PVC	: 2534	gr/m
Ağırlık POLY	: 2520	gr/m
Ix	: 103,25	cm ⁴
Iy	: 25,33	cm ⁴

-  W-602-b
-  W-612-b
-  W-606-b
-  W-608-b
-  W-608\2-b
-  W-602-a
-  W-612-a
-  W-607-b

W6
W 65-2 T YALITIMLI SERİ PROFİLLERİ
W65-2 T INSULATED SERIES

ÜRÜN TEKNİK ÖZELLİKLERİ
PRODUCT'S TECHNICAL FEATURES

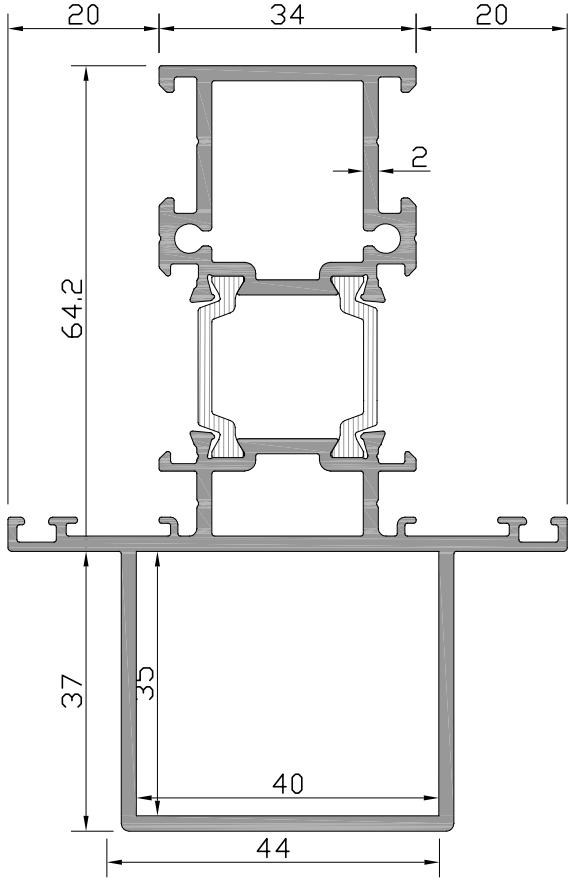

Profil No: W6-308-b

Ağırlık PVC	: 2321	gr/m
Ağırlık POLY	: 2306	gr/m
I_x	: 59,28	cm ⁴
I_y	: 20,23	cm ⁴

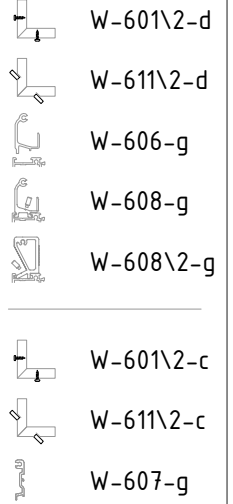

Profil No: W6-308-a

Ağırlık PVC	: 2440	gr/m
Ağırlık POLY	: 2425	gr/m
I_x	: 77,17	cm ⁴
I_y	: 22,18	cm ⁴

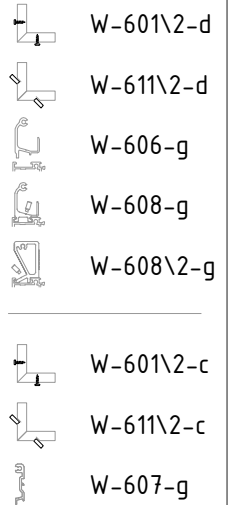
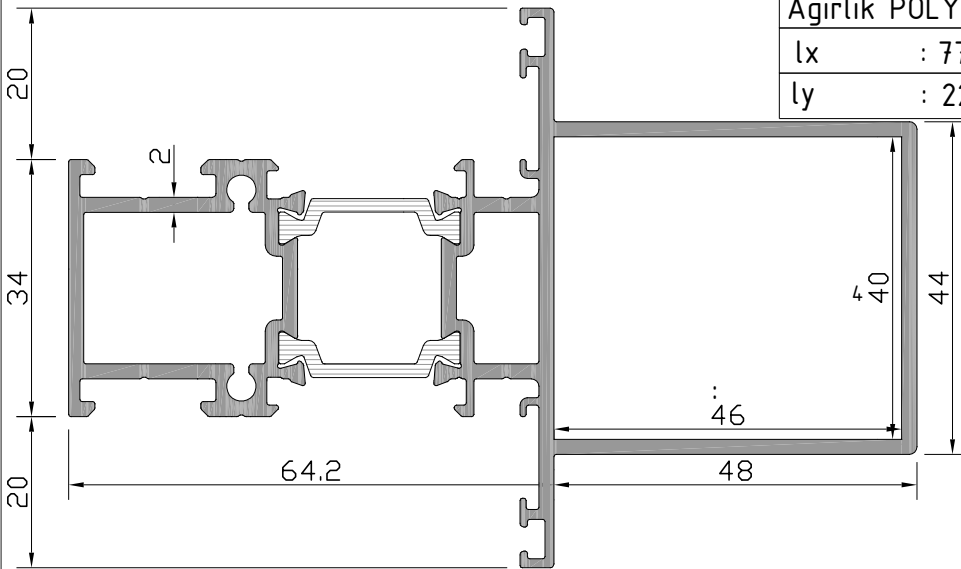





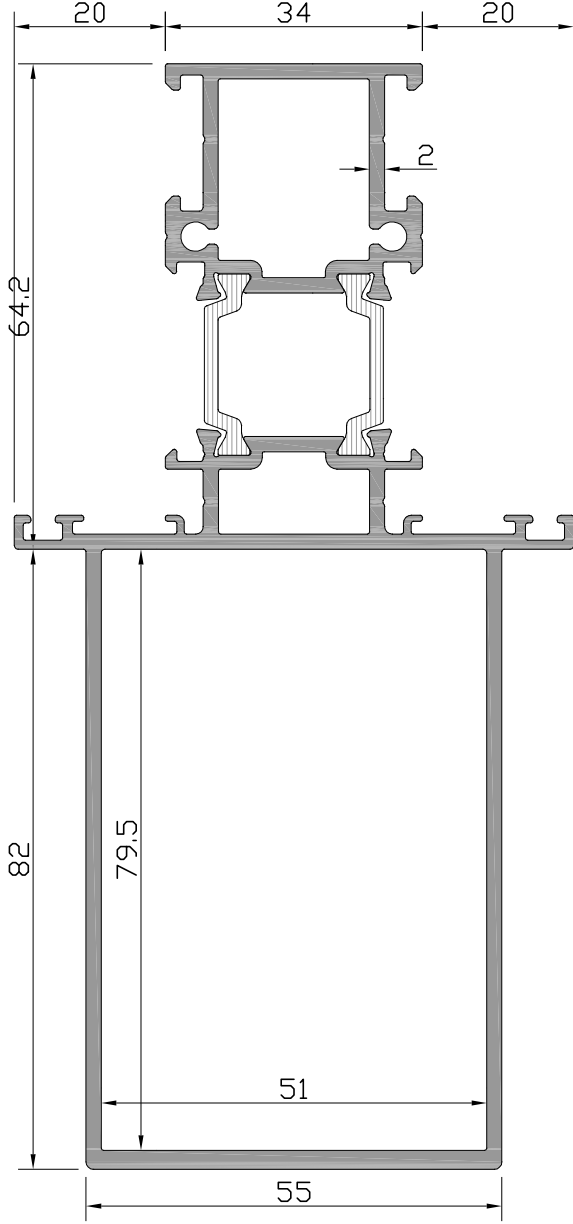



W6
W 65-2 T YALITIMLI SERİ PROFİLLERİ
W65-2 T INSULATED SERIES

ÜRÜN TEKNİK ÖZELLİKLERİ
PRODUCT'S TECHNICAL FEATURES



Profil No: W6-308-c

Ağırlık PVC	: 2938	gr/m
Ağırlık POLY	: 2923	gr/m
lx	: 182,51	cm ⁴
ly	: 38,44	cm ⁴

-  W-601\2-d
-  W-611\2-d
-  W-606-g
-  W-608-g
-  W-608\2-g
-  W-601\2-c
-  W-611\2-c
-  W-607-g

W6
W 65-2 T YALITIMLI SERİ PROFİLLERİ
W65-2 T INSULATED SERIES

ÜRÜN TEKNİK ÖZELLİKLERİ
PRODUCT'S TECHNICAL FEATURES

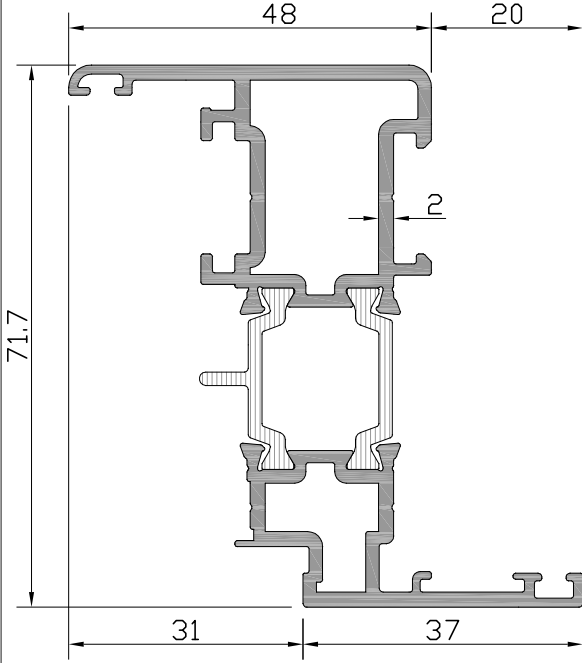

Profil No: W6-201

Ağırlık PVC	: 1601	gr/m
Ağırlık PÖLY	: 1585	gr/m
lx	: 26,54	cm ⁴
ly	: 8,22	cm ⁴

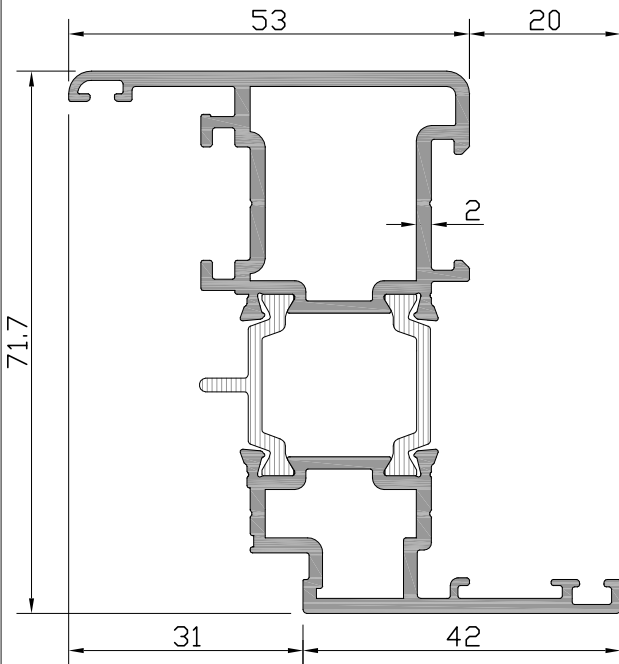
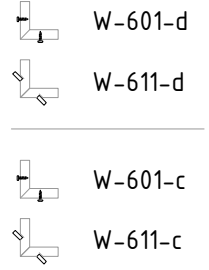

Profil No: W6-218

Ağırlık PVC	: 1694	gr/m
Ağırlık POLY	: 1678	gr/m
lx	: 28,50	cm ⁴
ly	: 11,18	cm ⁴

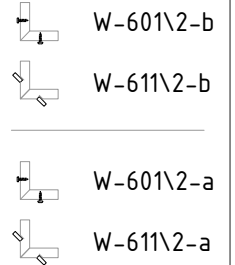

W6
W 65-2 T YALITIMLI SERİ PROFİLLERİ
W65-2 T INSULATED SERIES

ÜRÜN TEKNİK ÖZELLİKLERİ
PRODUCT'S TECHNICAL FEATURES

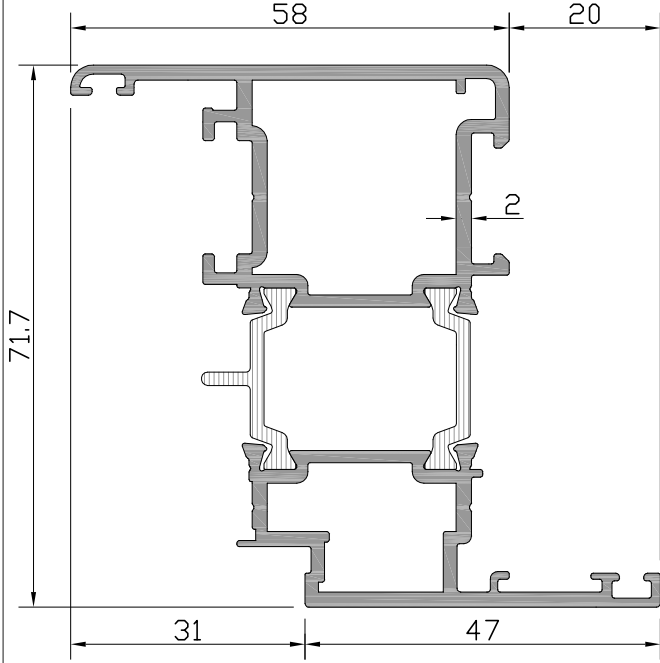

Profil No: W6-202

Ağırlık PVC	: 1808	gr/m
Ağırlık POLY	: 1792	gr/m
lx	: 30,87	cm ⁴
ly	: 14,97	cm ⁴

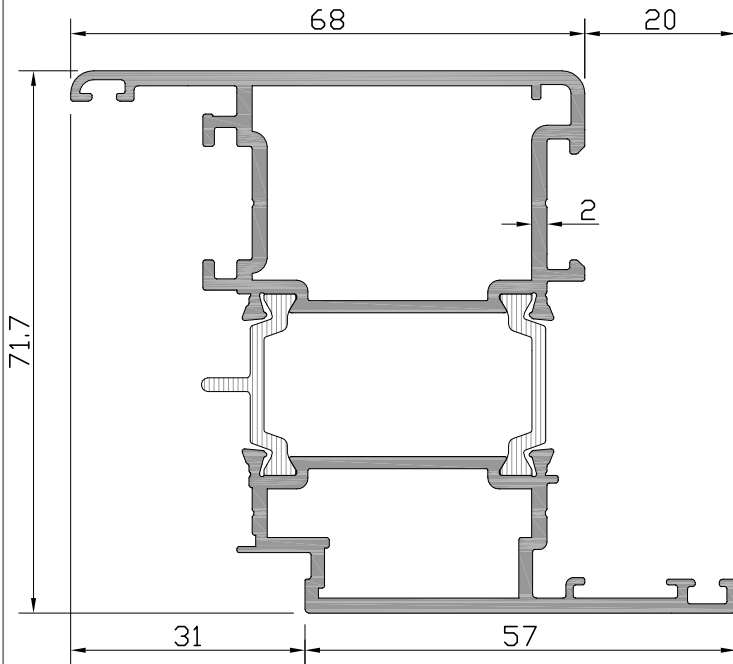
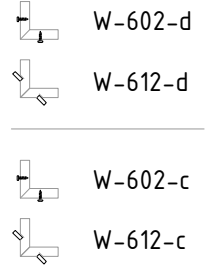

Profil No: W6-203

Ağırlık PVC	: 2003	gr/m
Ağırlık POLY	: 1987	gr/m
lx	: 34,95	cm ⁴
ly	: 24,68	cm ⁴

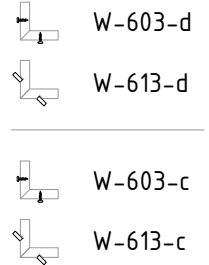

W6
W 65-2 T YALITIMLI SERİ PROFİLLERİ
W65-2 T INSULATED SERIES

ÜRÜN TEKNİK ÖZELLİKLERİ
PRODUCT'S TECHNICAL FEATURES

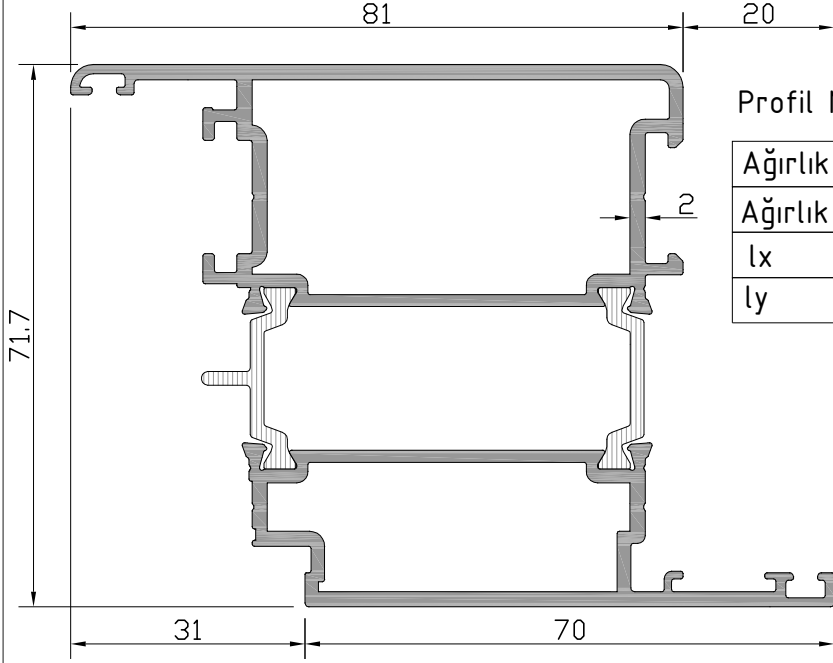

Profil No: W6-213

Ağırlık PVC	: 2240	gr/m
Ağırlık POLY	: 2224	gr/m
lx	: 39,92	cm ⁴
ly	: 41,97	cm ⁴

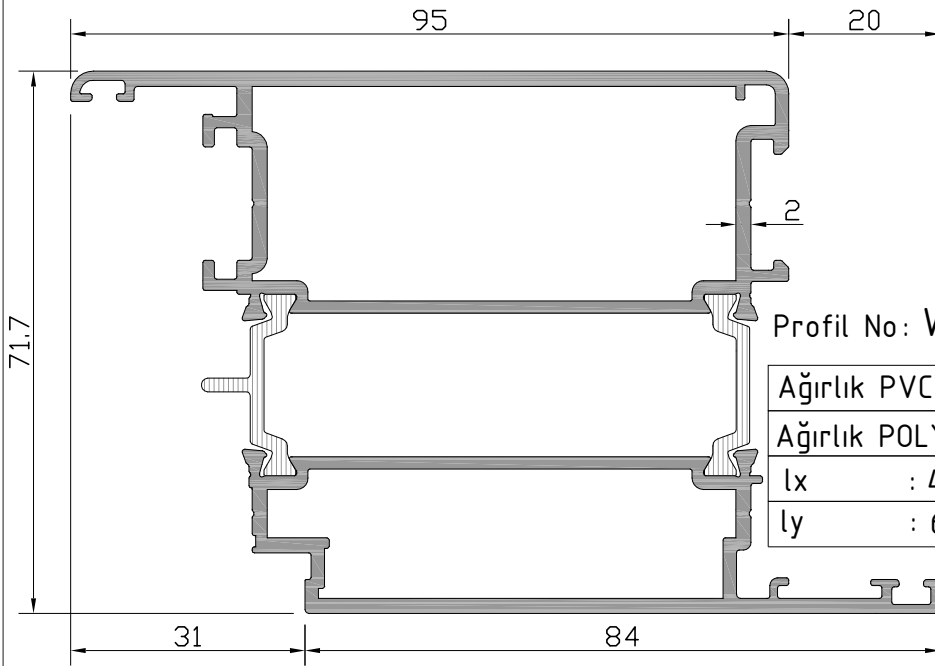
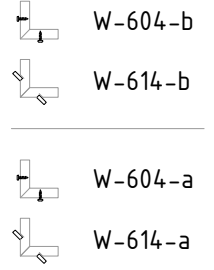

Profil No: W6-204

Ağırlık PVC	: 2526	gr/m
Ağırlık POLY	: 2510	gr/m
lx	: 45,83	cm ⁴
ly	: 68,35	cm ⁴

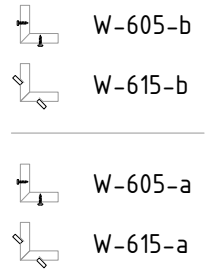





W6
W 65-2 T YALITIMLI SERİ PROFİLLERİ
W65-2 T INSULATED SERIES

ÜRÜN TEKNİK ÖZELLİKLERİ
PRODUCT'S TECHNICAL FEATURES

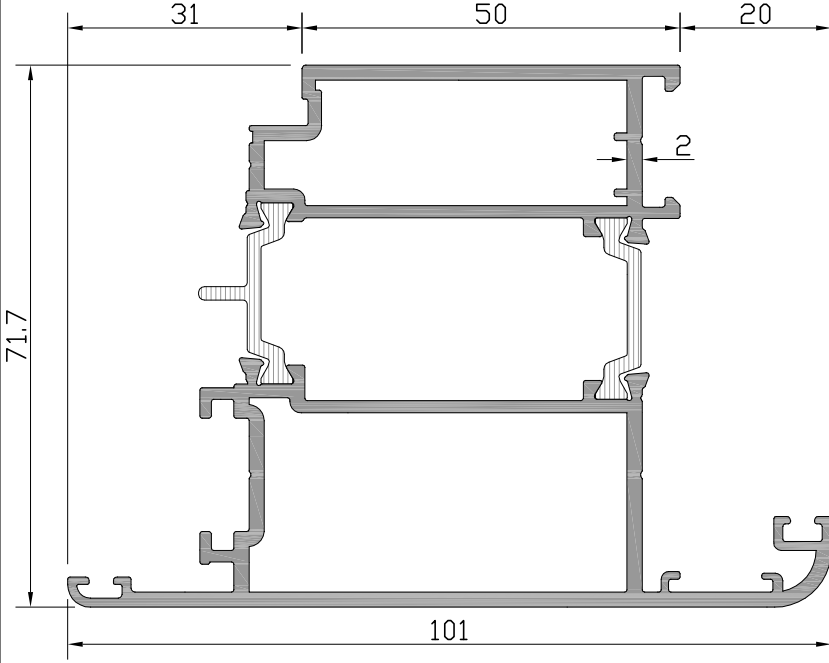
Profil No: W6-212

Ağırlık PVC	: 2298	gr/m
Ağırlık POLY	: 2282	gr/m
I_x	: 39,59	cm ⁴
I_y	: 47,17	cm ⁴





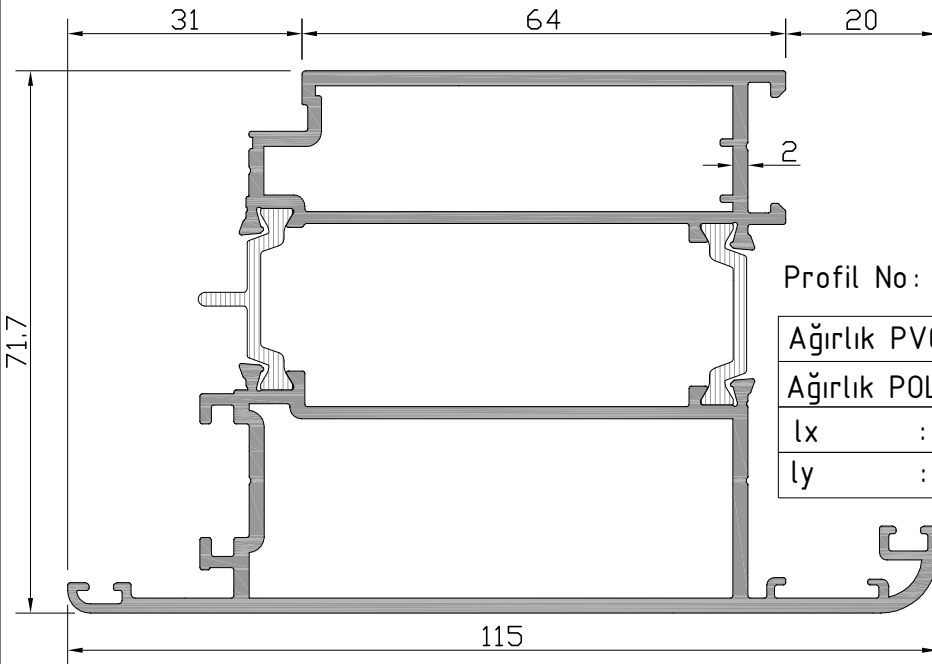

-  W-604-a
-  W-614-a
-  W-604-c
-  W-614-c

Profil No: W6-206

Ağırlık PVC	: 2568	gr/m
Ağırlık POLY	: 2552	gr/m
I_x	: 45,55	cm ⁴
I_y	: 74,43	cm ⁴



-  W-605-a
-  W-615-a
-  W-605-c
-  W-615-c

W6
W 65-2 T YALITIMLI SERİ PROFİLLERİ
W65-2 T INSULATED SERIES

ÜRÜN TEKNİK ÖZELLİKLERİ
PRODUCT'S TECHNICAL FEATURES

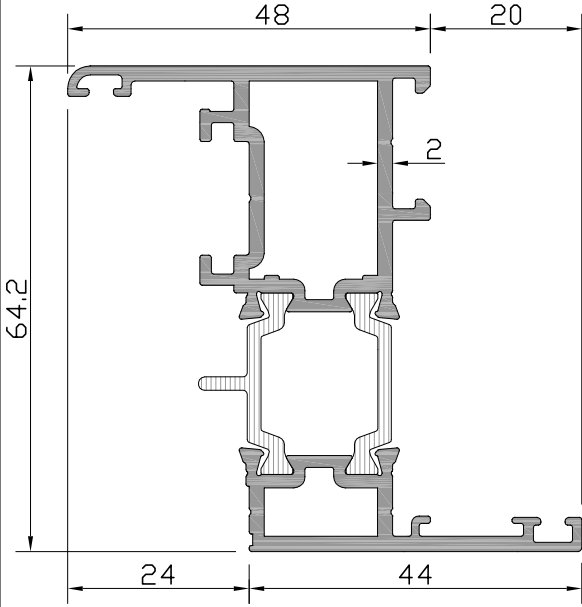

Profil No: W6-216

Ağırlık PVC	: 1497	gr/m
Ağırlık POLY	: 1481	gr/m
I_x	: 20,74	cm^4
I_y	: 7,88	cm^4

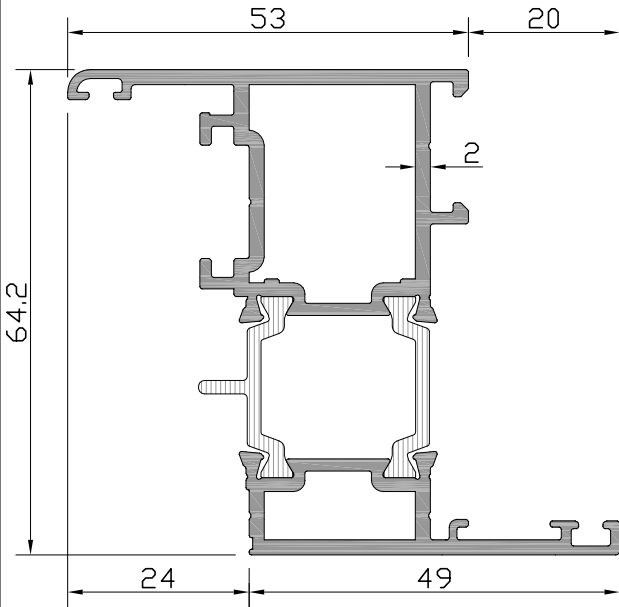
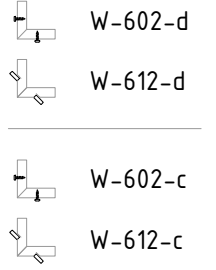

Profil No: W6-219

Ağırlık PVC	: 1594	gr/m
Ağırlık POLY	: 1578	gr/m
I_x	: 22,49	cm^4
I_y	: 10,72	cm^4

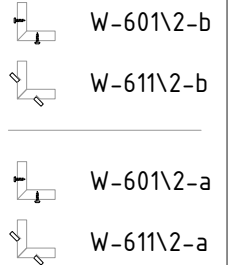

W6
W 65-2 T YALITIMLI SERİ PROFİLLERİ
W65-2 T INSULATED SERIES

ÜRÜN TEKNİK ÖZELLİKLERİ
PRODUCT'S TECHNICAL FEATURES

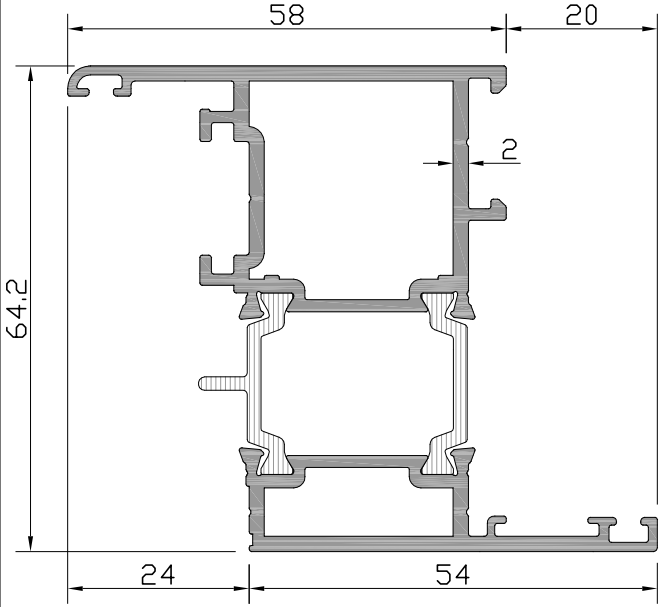

Profil No: W6-217

Ağırlık PVC	: 1692	gr/m
Ağırlık POLY	: 1676	gr/m
lx	: 24,24	cm ⁴
ly	: 14,20	cm ⁴

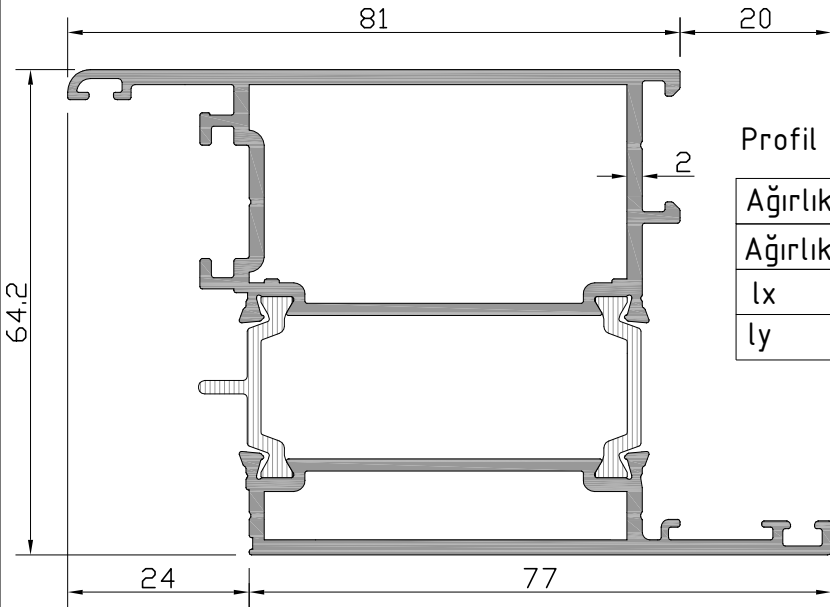
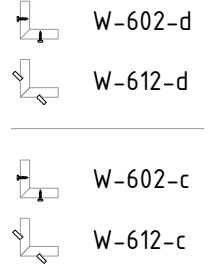

Profil No: W6-214

Ağırlık PVC	: 2137	gr/m
Ağırlık POLY	: 2121	gr/m
lx	: 32,14	cm ⁴
ly	: 39,70	cm ⁴

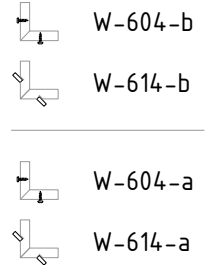

W6
W 65-2 T YALITIMLI SERİ PROFİLLERİ
W65-2 T INSULATED SERIES

ÜRÜN TEKNİK ÖZELLİKLERİ
PRODUCT'S TECHNICAL FEATURES

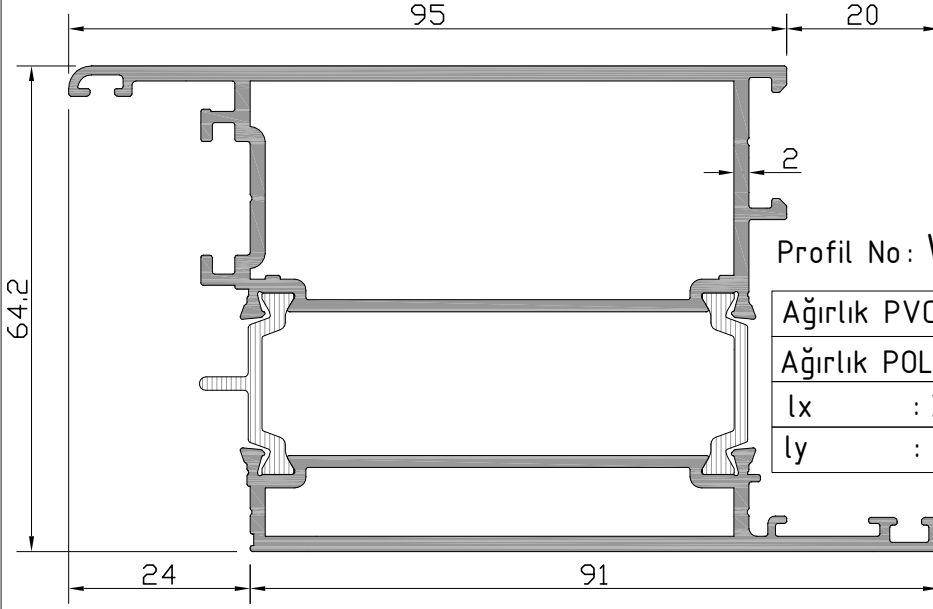

Profil No: W6-205

Ağırlık PVC	: 2415	gr/m
Ağırlık POLY	: 2399	gr/m
Ix	: 36,97	cm ⁴
Iy	: 64,40	cm ⁴

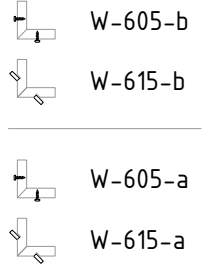

Profil No: W6-215

Ağırlık PVC	: 2187	gr/m
Ağırlık POLY	: 2171	gr/m
Ix	: 31,94	cm ⁴
Iy	: 40,80	cm ⁴

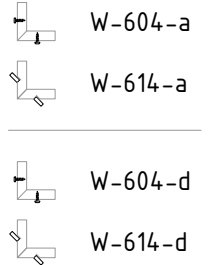
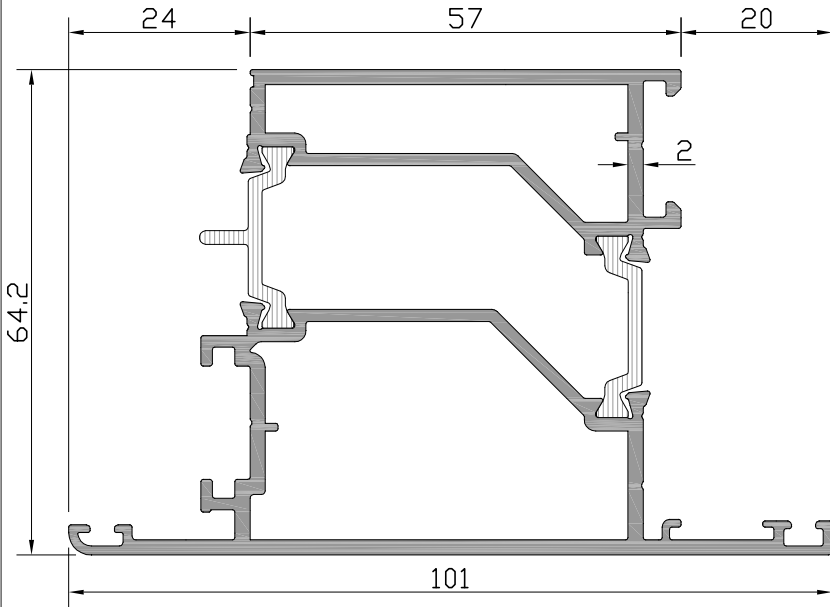

W6
W 65-2 T YALITIMLI SERİ PROFİLLERİ
W65-2 T INSULATED SERIES

ÜRÜN TEKNİK ÖZELLİKLERİ
PRODUCT'S TECHNICAL FEATURES

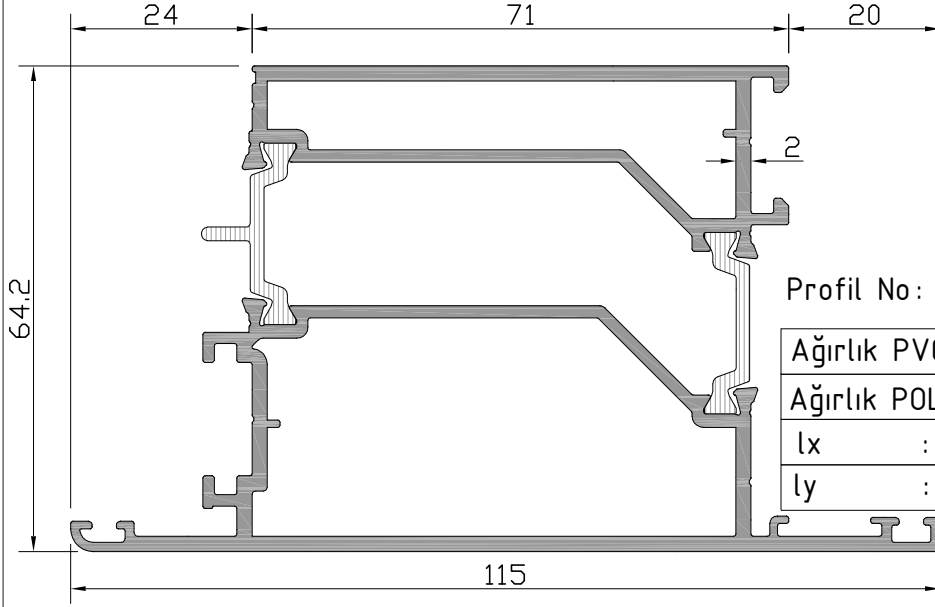

Profil No: W6-207

Ağırlık PVC	: 2460	gr/m
Ağırlık POLY	: 2444	gr/m
lx	: 37,01	cm ⁴
ly	: 65,91	cm ⁴

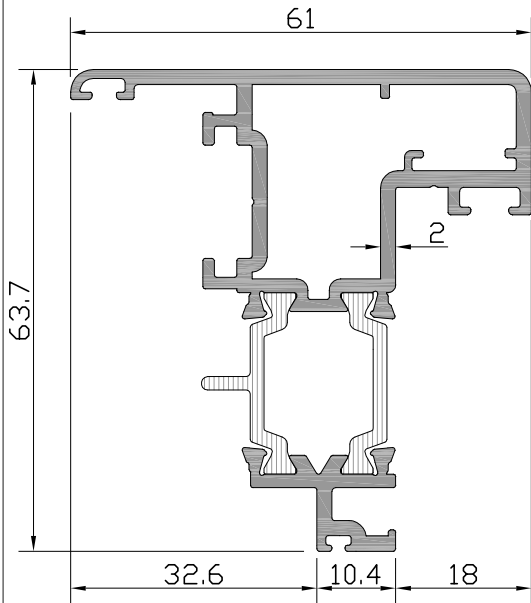
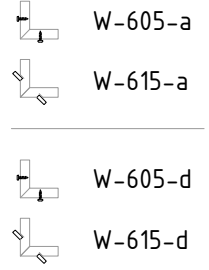

Profil No: W6-208

Ağırlık PVC	: 1465	gr/m
Ağırlık POLY	: 1449	gr/m
lx	: 14,71	cm ⁴
ly	: 9,35	cm ⁴

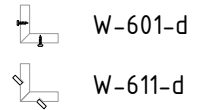

W6
W 65-2 T YALITIMLI SERİ PROFİLLERİ
W65-2 T INSULATED SERIES

ÜRÜN TEKNİK ÖZELLİKLERİ
PRODUCT'S TECHNICAL FEATURES

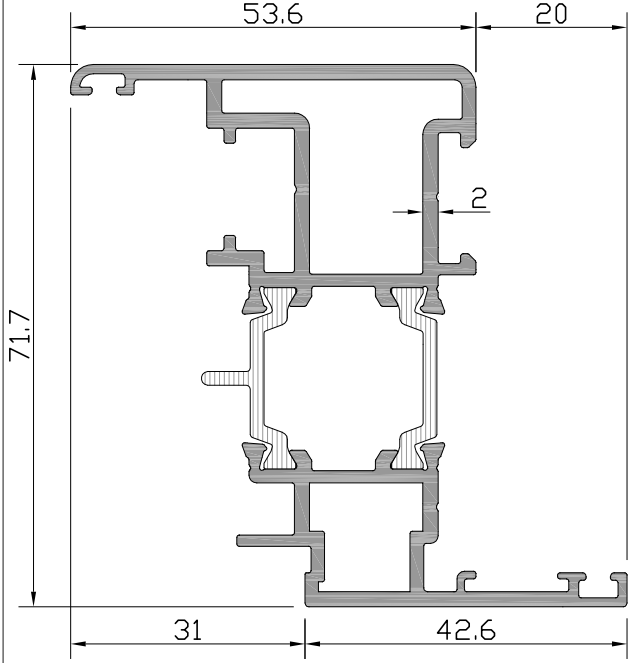

Profil No: W6-209

Ağırlık PVC	: 1770	gr/m
Ağırlık POLY	: 1754	gr/m
lx	: 29,67	cm ⁴
ly	: 11,29	cm ⁴

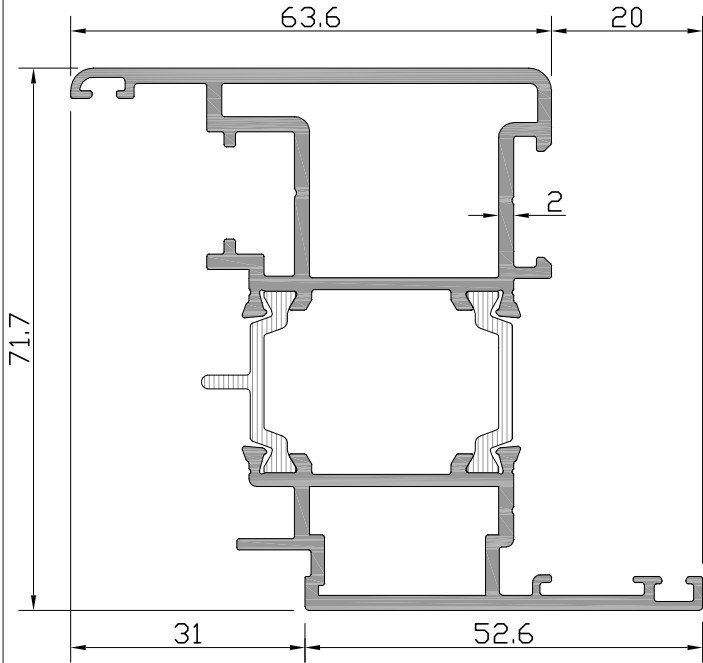
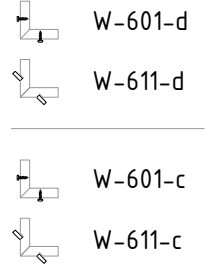

Profil No: W6-210

Ağırlık PVC	: 1965	gr/m
Ağırlık POLY	: 1949	gr/m
lx	: 33,85	cm ⁴
ly	: 19,53	cm ⁴

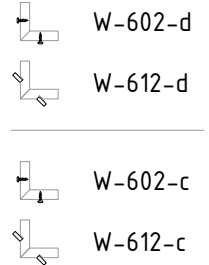





W6
W 65-2 T YALITIMLI SERİ PROFİLLERİ
W65-2 T INSULATED SERIES

ÜRÜN TEKNİK ÖZELLİKLERİ
PRODUCT'S TECHNICAL FEATURES

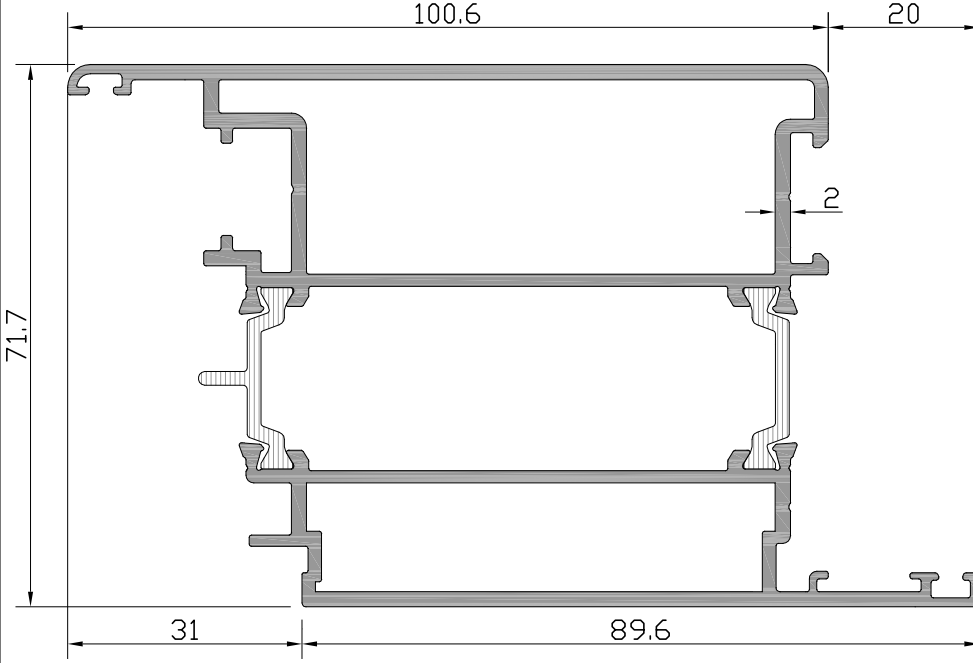
Profil No: W6-211

Ağırlık PVC	: 2679	gr/m
Ağırlık POLY	: 2663	gr/m
Ix	: 49,05	cm ⁴
Iy	: 80,71	cm ⁴



-  W-605-b
-  W-615-b
-  W-605-a
-  W-615-a

W6
W 65-2 T YALITIMLI SERİ PROFİLLERİ
W65-2 T INSULATED SERIES

ÜRÜN TEKNİK ÖZELLİKLERİ
PRODUCT'S TECHNICAL FEATURES

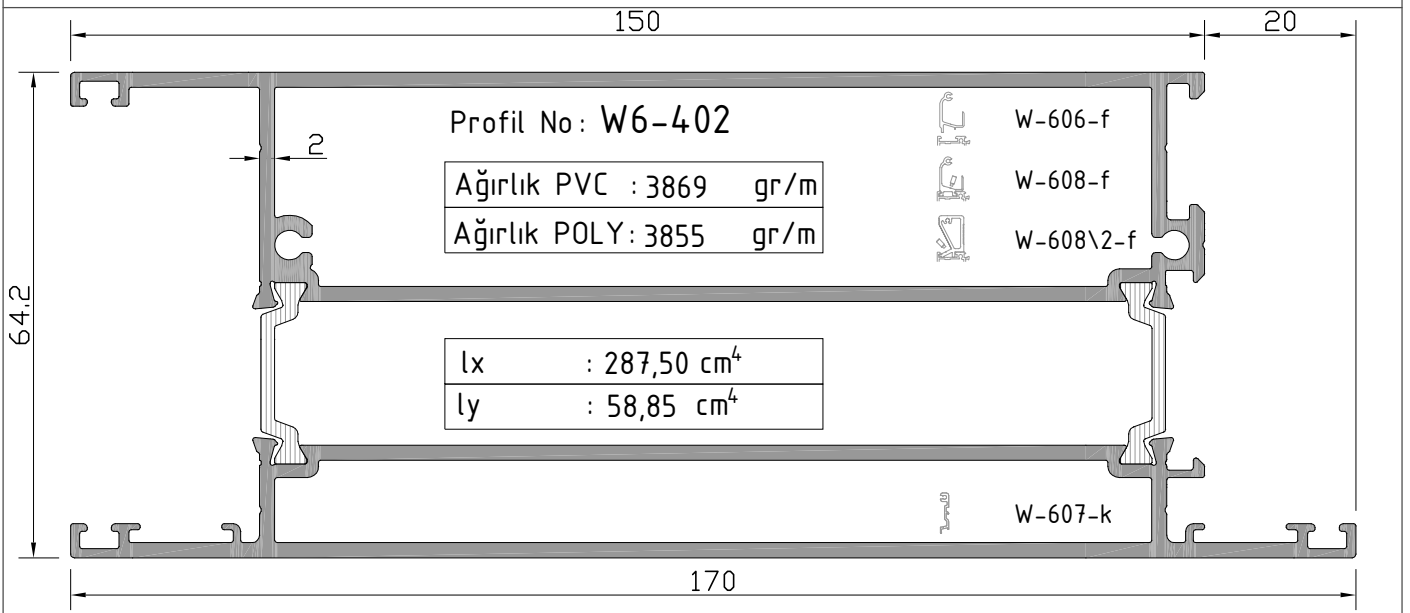
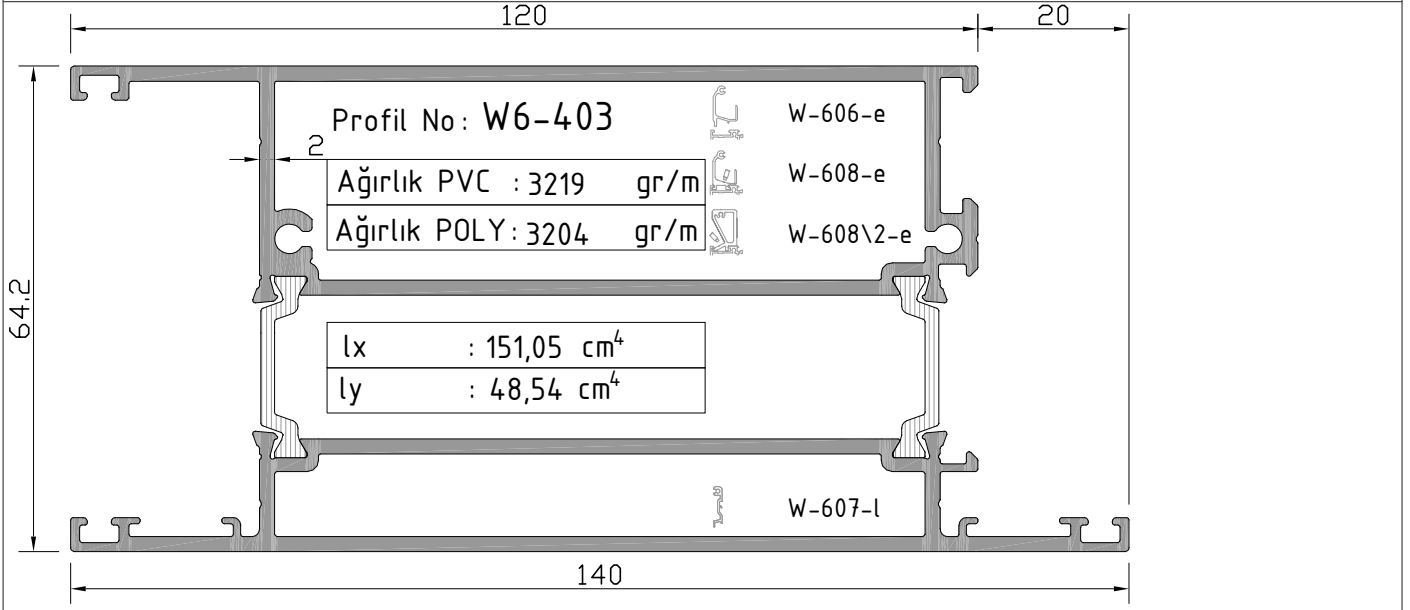
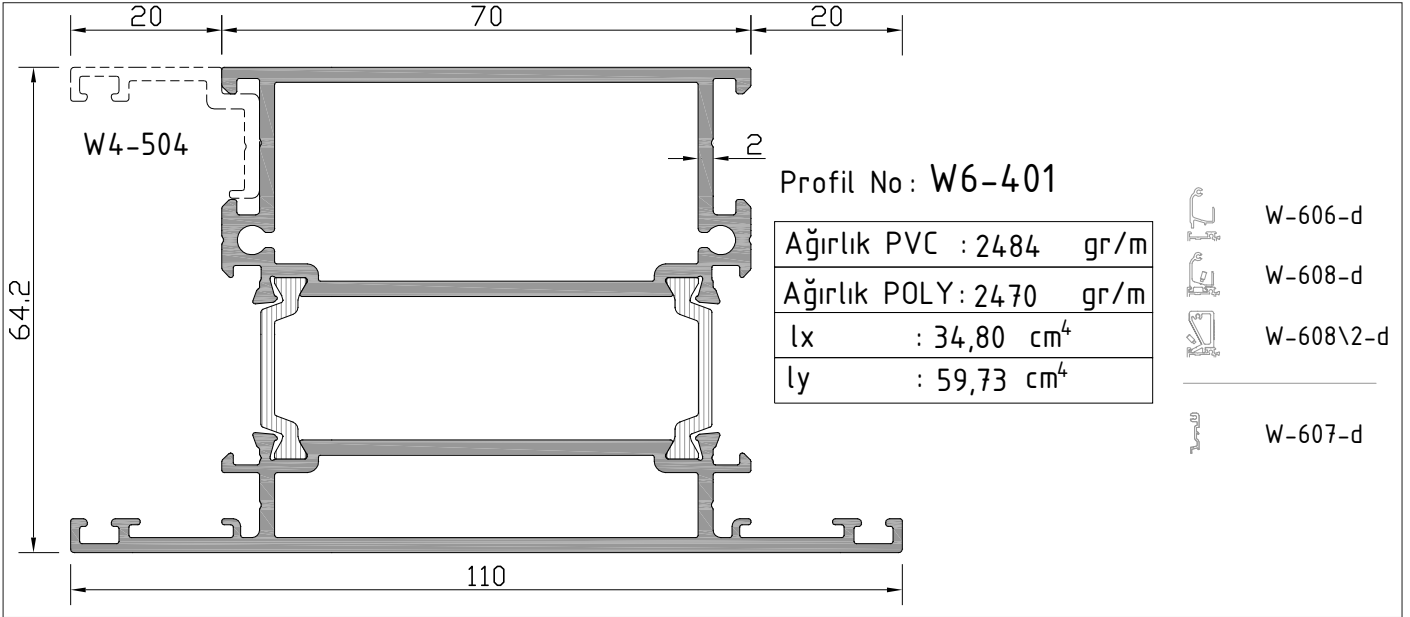

Profil değerleri teoriktir. Ağırlık olarak testimde yapılan tartım geçerlidir.
Profil imalatları TS EN 12020-2 ve TS EN 755-9 toleransı,
Moment değerleri EN 14024'e göre hesaplanmıştır.

Profile values are theoretical pre-shipment weight will be valid.
The tolerances of Profile manufacturing are calculated according to EN 12020-2
and TS EN 755-9; moment values are calculated according to EN 14024.

W6
W 65-2 T YALITIMLI SERİ PROFİLLERİ
W65-2 T INSULATED SERIES

ÜRÜN TEKNİK ÖZELLİKLERİ
PRODUCT'S TECHNICAL FEATURES

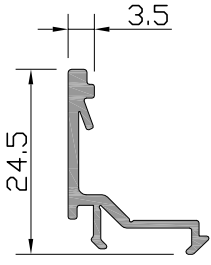

Profil No: W-511
Ağırlık : 187 gr/m

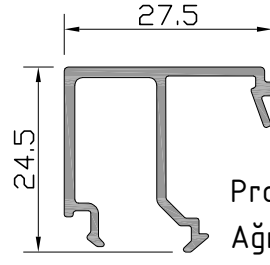

Profil No: W-517
Ağırlık : 299 gr/m

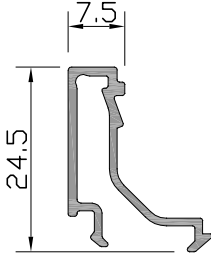

Profil No: W-512
Ağırlık : 206 gr/m

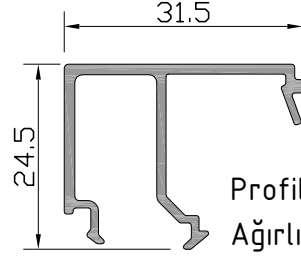

Profil No: W-518
Ağırlık : 316 gr/m

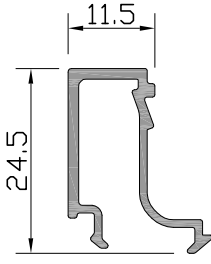

Profil No: W-513
Ağırlık : 227 gr/m

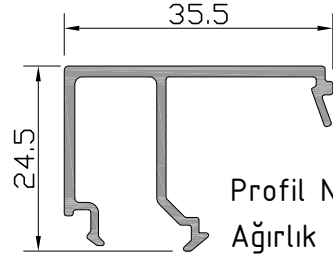

Profil No: W-519
Ağırlık : 336 gr/m

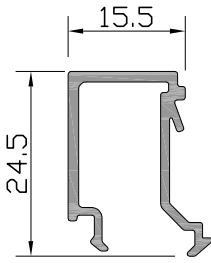

Profil No: W-514
Ağırlık : 252 gr/m

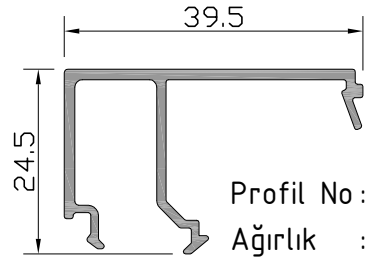

Profil No: W-520
Ağırlık : 351 gr/m

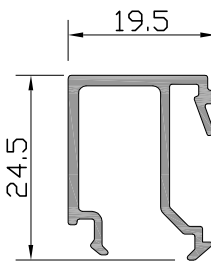

Profil No: W-515
Ağırlık : 273 gr/m

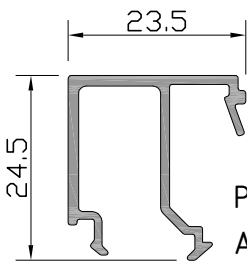

Profil No: W-516
Ağırlık : 286 gr/m

W6
W 65-2 T YALITIMLI SERİ PROFİLLERİ
W65-2 T INSULATED SERIES

CAM - FİTİL - CAM ÇİTASI
GLAZING-GASKET-GLAZING BELT

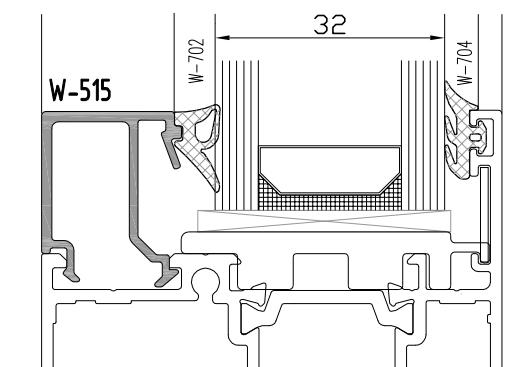
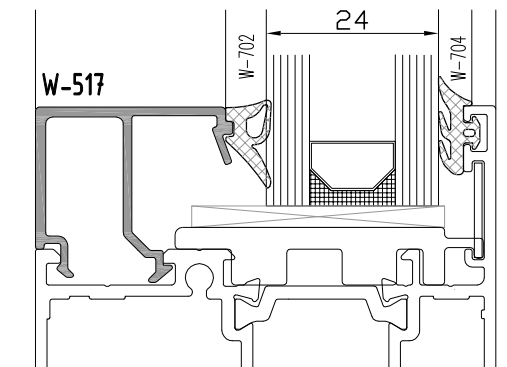
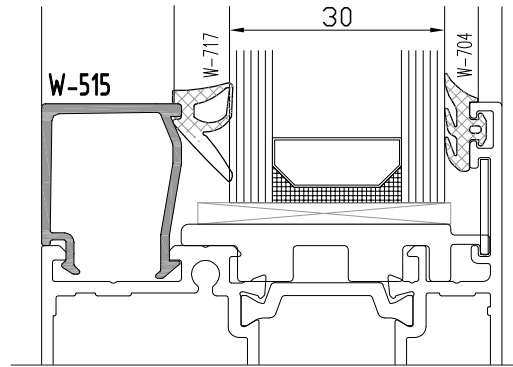
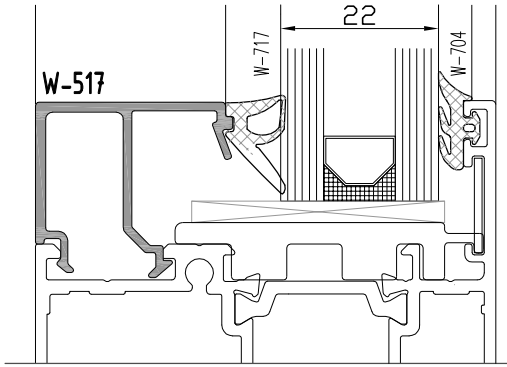
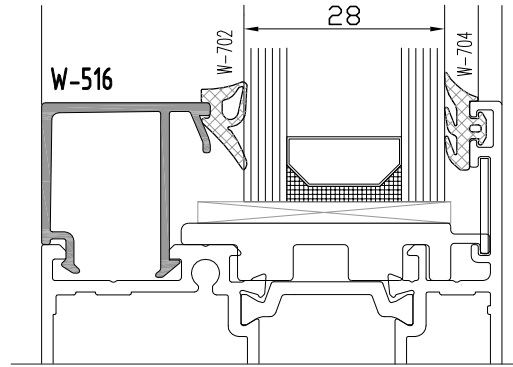
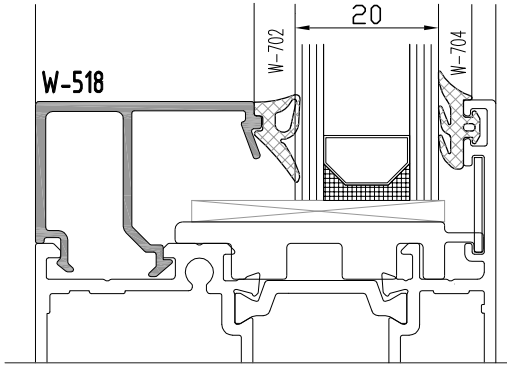
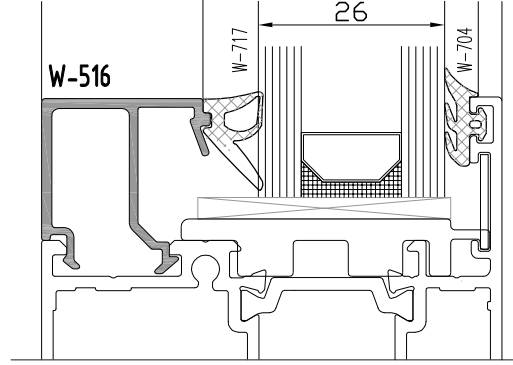
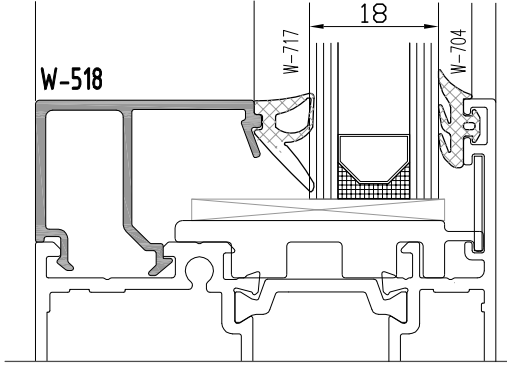

W6

W 65-2 T YALITIMLI SERİ PROFİLLERİ

W65-2 T INSULATED SERIES

CAM - FİTİL - CAM ÇİTASI
GLAZING-GASKET-GLAZING BELT

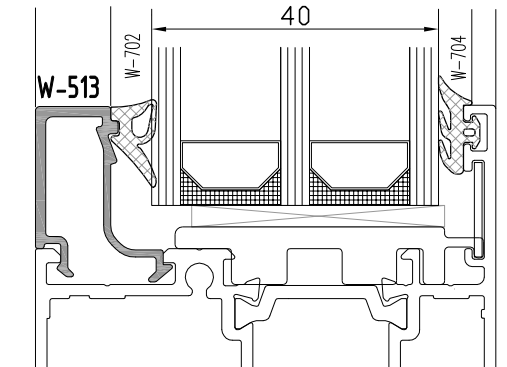
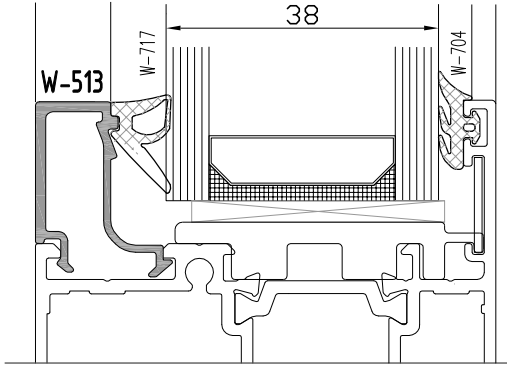
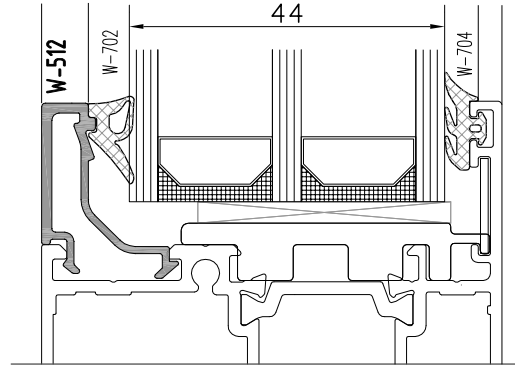
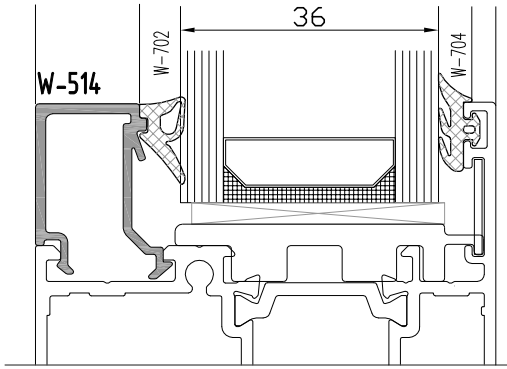
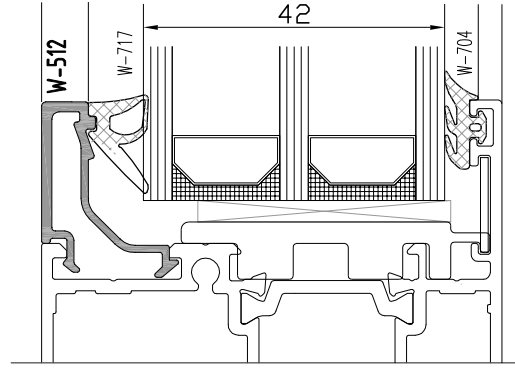
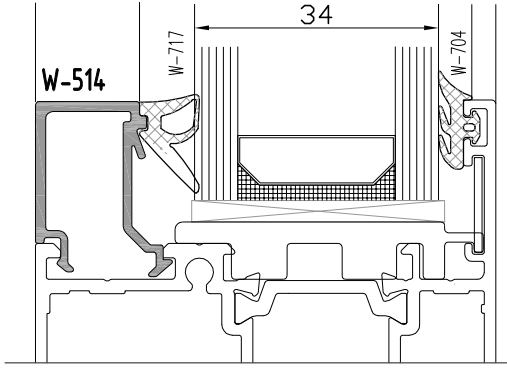

Profil değerleri teoriktir. Ağırlık olarak testimde yapılan tartım geçerlidir.
Profil imalatları TS EN 12020-2 ve TS EN 755-9 toleransı,
Moment değerleri EN 14024'e göre hesaplanmıştır.

Profile values are theoretical pre-shipment weight will be valid.
The tolerances of Profile manufacturing are calculated according to EN 12020-2
and TS EN 755-9; moment values are calculated according to EN 14024.

W6
W 65-2 T YALITIMLI SERİ PROFİLLERİ
W65-2 T INSULATED SERIES

ÜRÜN TEKNİK ÖZELLİKLERİ
PRODUCT'S TECHNICAL FEATURES

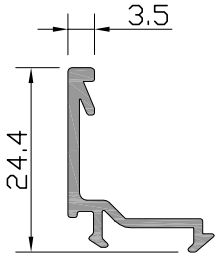

Profil No: W-511-a ⚠

Ağırlık : 193 gr/m

⚠ İşaretti profil için satış temsilcinizden bilgi alınız.

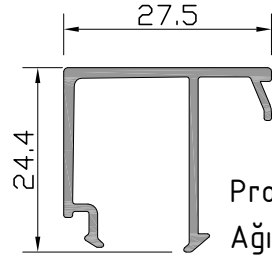

Profil No: W-517-a

Ağırlık : 284 gr/m

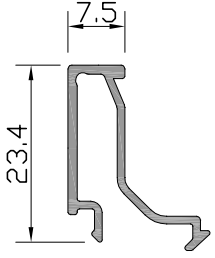

Profil No: W-512-a

Ağırlık : 194 gr/m

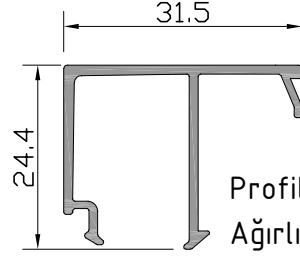

Profil No: W-518-a

Ağırlık : 297 gr/m

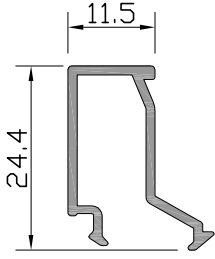

Profil No: W-513-a

Ağırlık : 216 gr/m

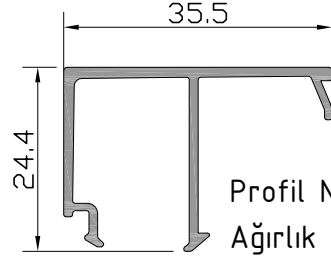

Profil No: W-519-a

Ağırlık : 316 gr/m

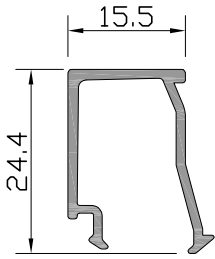

Profil No: W-514-a

Ağırlık : 228 gr/m

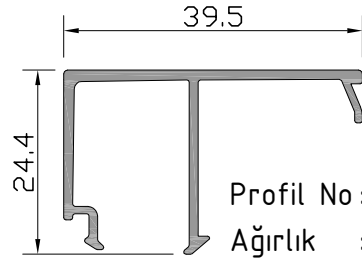

Profil No: W-520-a

Ağırlık : 330 gr/m

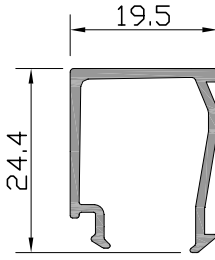

Profil No: W-515-a

Ağırlık : 242 gr/m

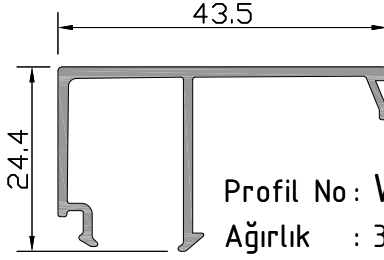

Profil No: W-521-a

Ağırlık : 344 gr/m

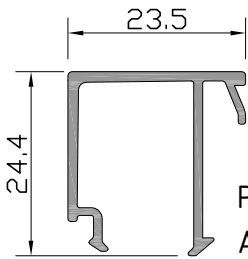

Profil No: W-516-a

Ağırlık : 270 gr/m

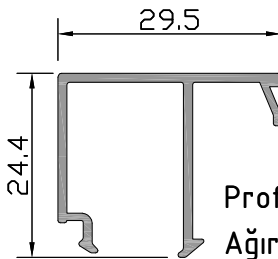

Profil No: W-522-a

Ağırlık : 278 gr/m

W6

W 65-2 T YALITIMLI SERİ PROFİLLERİ W65-2 T INSULATED SERIES

CAM - FİTİL - CAM ÇİTASI
GLAZING-GASKET-GLAZING BELT

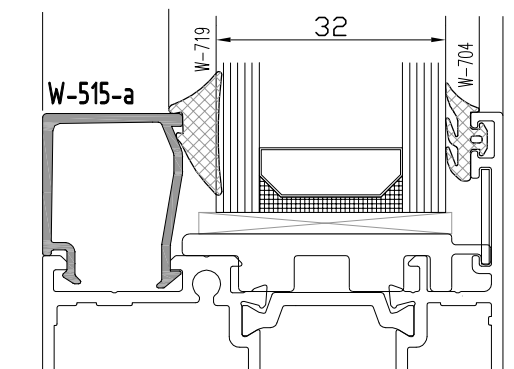
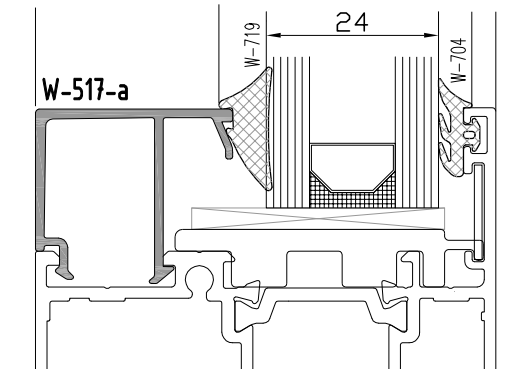
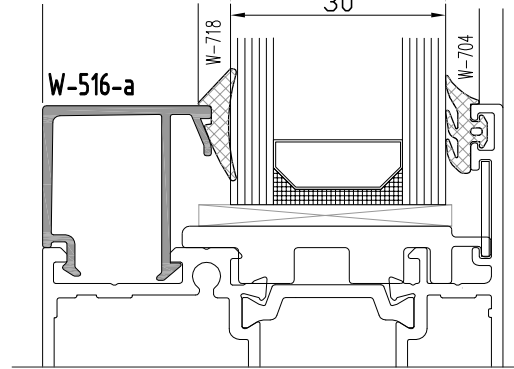
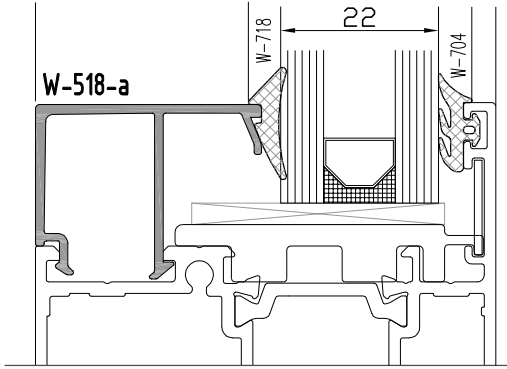
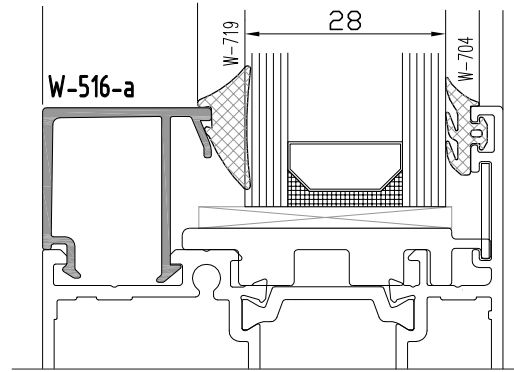
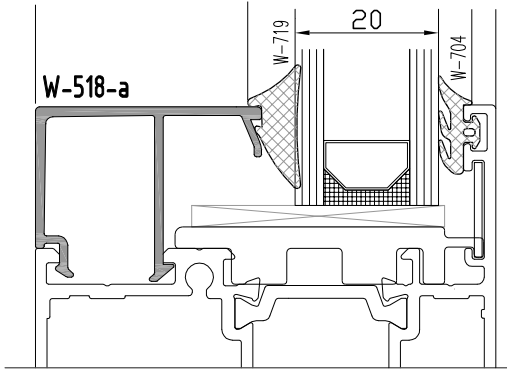
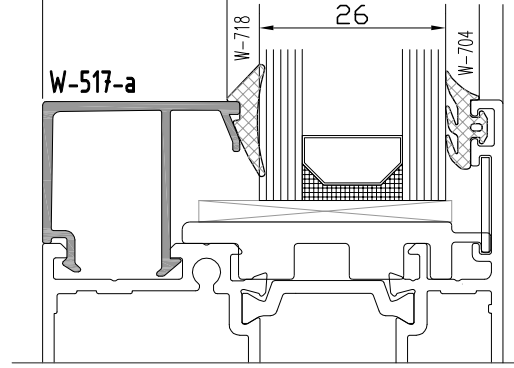
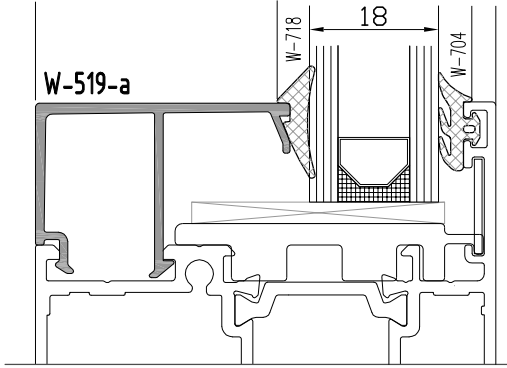

Profil değerleri teoriktir. Ağırlık olarak testimde yapılan tartım geçerlidir.
Profil imatları TS EN 12020-2 ve TS EN 755-9 toleransı,
Moment değerleri EN 14024'e göre hesaplanmıştır.

Profile values are theoretical pre-shipment weight will be valid.
The tolerances of Profile manufacturing are calculated according to EN 12020-2
and TS EN 755-9; moment values are calculated according to EN 14024.

W6
W 65-2 T YALITIMLI SERİ PROFİLLERİ
W65-2 T INSULATED SERIES

CAM - FİTİL - CAM ÇİTASI
GLAZING-GASKET-GLAZING BELT

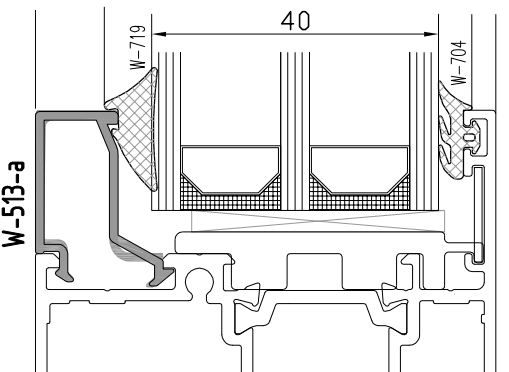
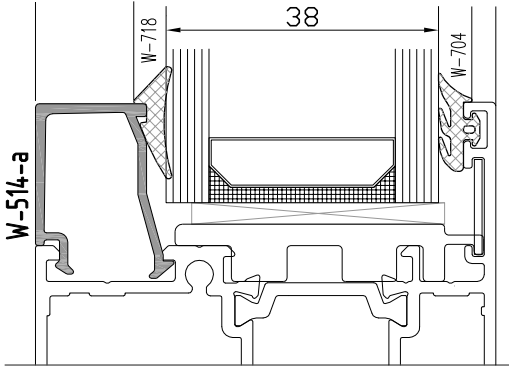
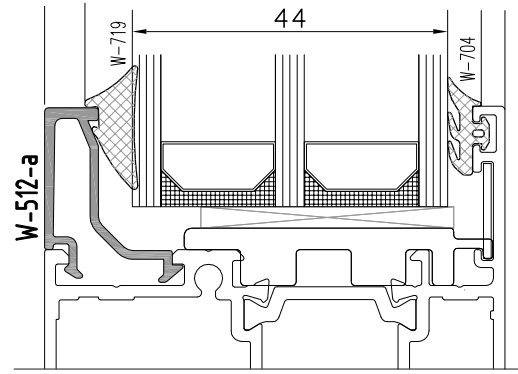
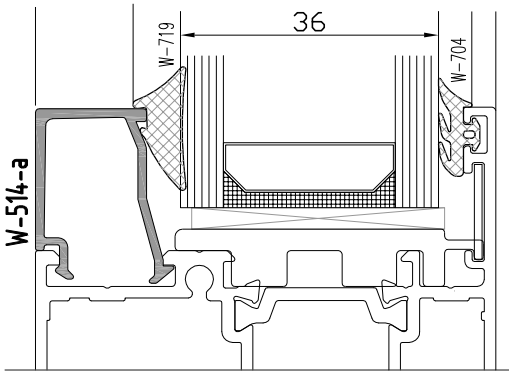
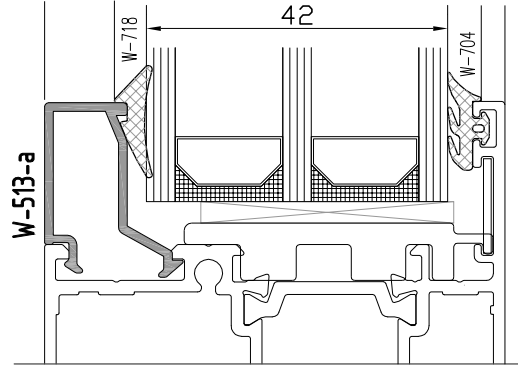
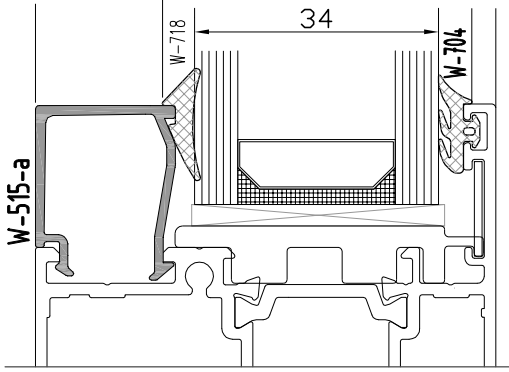

W6
W 65-2 T YALITIMLI SERİ PROFİLLERİ
W65-2 T INSULATED SERIES

ÜRÜN TEKNİK ÖZELLİKLERİ
PRODUCT'S TECHNICAL FEATURES

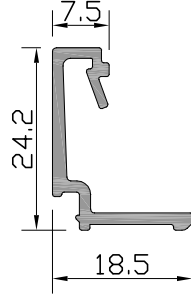

Profil No : W-512-B
Ağırlık : 227 gr/m

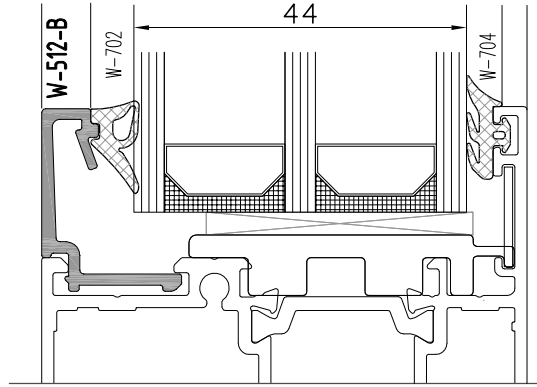
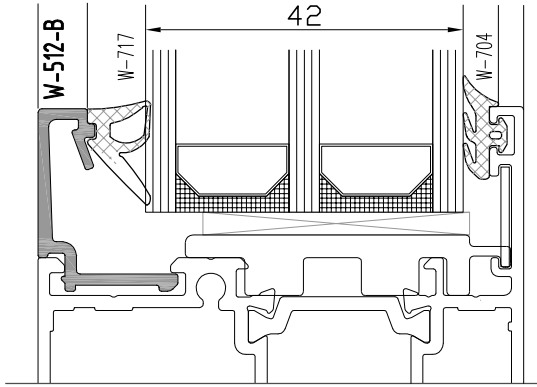

W6
W 65-2 T YALITIMLI SERİ PROFİLLERİ
W65-2 T INSULATED SERIES

ÜRÜN TEKNİK ÖZELLİKLERİ
PRODUCT'S TECHNICAL FEATURES

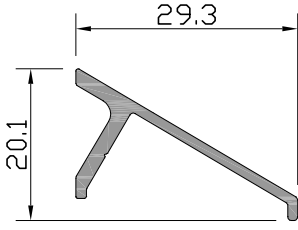

Profil No: **W-503**
Ağırlık : 211 gr/m

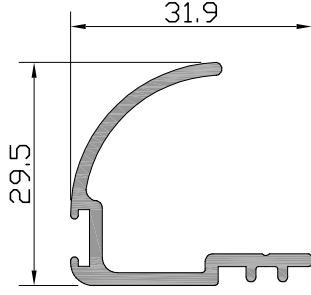

Profil No: **W-506** ⚠
Ağırlık : 363 gr/m
⚠ İşaretili profil için satış temsilcinizden bilgi alınız.

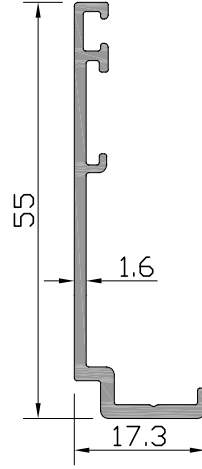

Profil No: **W4-508**
Ağırlık : 356 gr/m

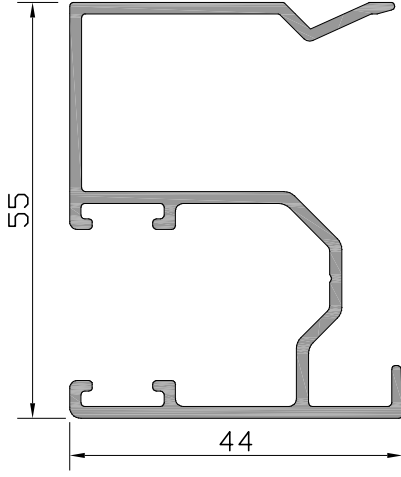

Profil No: **W-507** ⚠
Ağırlık : 834 gr/m
⚠ İşaretili profil için satış temsilcinizden bilgi alınız.

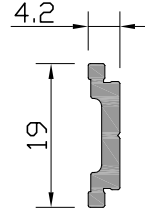

Profil No: **W1-508**
Ağırlık : 138 gr/m

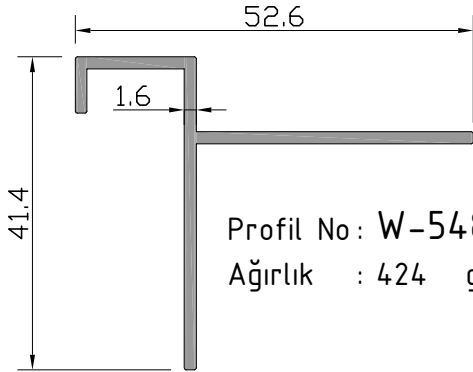

Profil No: **W-548**
Ağırlık : 424 gr/m

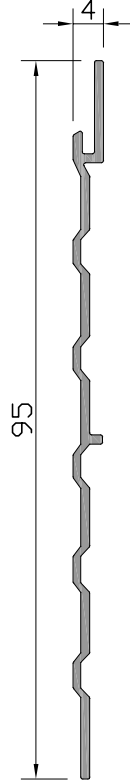

Profil No: **W-509**
Ağırlık : 319 gr/m

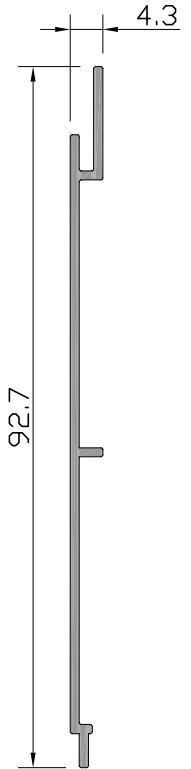

Profil No: **W-510**
Ağırlık : 342 gr/m

W6

ÜRÜN TEKNİK ÖZELLİKLERİ PRODUCT'S TECHNICAL FEATURES

PROFİL KESİTİ PROFILE VIEW	PROFİL NO PROFILE NO	PROFİL AÇIKLAMASI PROFILE DESCRIPTION	gr/m	PROFİL KESİTİ PROFILE VIEW	PROFİL NO PROFILE NO	PROFİL AÇIKLAMASI PROFILE DESCRIPTION	gr/m
	W6-512 (107 - 31)	ÇİFT KANAT ADAPTÖRÜ CASEMENT PROFILE ADAPTOR	PVC 1734 POLYAMID 1719		W-608\2 (23.6 - 39.5)	ORTA KAYIT BİRLEŞTİRME CORNER CLEATS FOR TRANSOM	904
	W6-513 (12.8 - 25)	SAKLI KANAT SABİT ADAPT. HIDDEN CASEMENT PROFILE ADAPT.	PVC 959 POLYAMID 944		W4-508 (17.3 - 55)	PERVAZ ADAPTÖRÜ FRAME ADAPTER	356
	W65-555 (17 - 56.7)	EŞİK PROFİLİ THRESHOLD PROFILE	PVC 824 POLYAMID 810		W-548 (52.6 - 41.4)	BİNİ PROFİLİ INTERLOCKING PROFILE	424
	W-557 (24.5 - 20.5)	ETEK ADAPTÖRÜ PLINTH ADAPTER	260				
	W-558 (37.6 - 20)	ETEK ADAPTÖRÜ PLINTH ADAPTER	173				
	W-559 (37.6 - 20)	ETEK ADAPTÖRÜ PLINTH ADAPTER	216				
	W3-507 (8.2 - 26)	SAKLI KANAT CAM ÇİTASI GLASS SKIRTING FOR HIDDEN CASEM.	155				
	W-534 (40 - 26.5)	BİNİ PROFİLİ INTERLOCKING PROFILE	328				
	SC0307 (55 - 55)	KÖŞE BİRLEŞTİRME CORNER CLEATS	1737				
	SC0309 (55 - 55)	KÖŞE BİRLEŞTİRME CORNER CLEATS	1573				

Profil değerleri teoriktir. Ağırlık olarak testimde yapılan tartım geçerlidir.
Profil imalatları TS EN 12020-2 ve TS EN 755-9 toleransı,
Moment değerleri EN 14024'e göre hesaplanmıştır.

Profile values are theoretical pre-shipment weight will be valid.
The tolerances of Profile manufacturing are calculated according to EN 12020-2
and TS EN 755-9; moment values are calculated according to EN 14024.

W6
W 65-2 T YALITIMLI SERİ PROFİLLERİ
W65-2 T INSULATED SERIES

ÜRÜN TEKNİK ÖZELLİKLERİ
PRODUCT'S TECHNICAL FEATURES

Profil No: W-527

Ağırlık : 1181 gr/m

2.2

160

ölçeksiz
not to scale

2.2

190

Profil No: W-532

Ağırlık : 1573 gr/m

Profil No: W-528

Ağırlık : 1367 gr/m

1.9

ölçeksiz
not to scale

ölçeksiz
not to scale

2.2

206.58

Profil No: W-531

Ağırlık : 1322 gr/m

170

Profil No: W-529

Ağırlık : 1577 gr/m

2.2

ölçeksiz
not to scale

ölçeksiz
not to scale

2.2

206.58

Profil No: W-530

Ağırlık : 1209 gr/m

150

Profil No: W-533

Ağırlık : 1696 gr/m

2.2

ölçeksiz
not to scale

ölçeksiz
not to scale

210

W6
W 65-2 T YALITIMLI SERİ PROFİLLERİ
W65-2 T INSULATED SERIES

ÜRÜN TEKNİK ÖZELLİKLERİ
PRODUCT'S TECHNICAL FEATURES

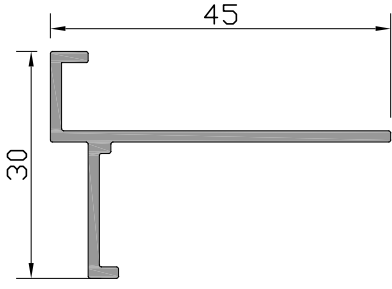

Profil No : W-534

Ağırlık : 328 gr/m

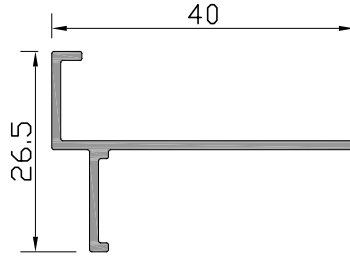

Profil No : W-535

Ağırlık : 229 gr/m

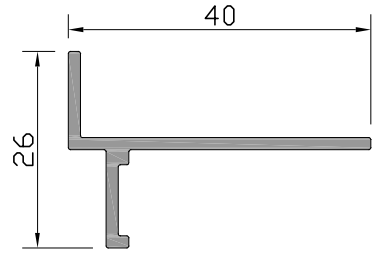

Profil No : W-536

Ağırlık : 292 gr/m

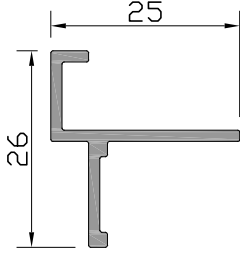

Profil No : W-537

Ağırlık : 226 gr/m

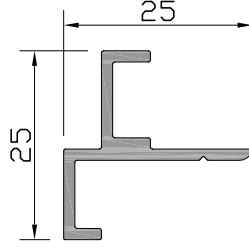

Profil No : W-538

Ağırlık : 249 gr/m

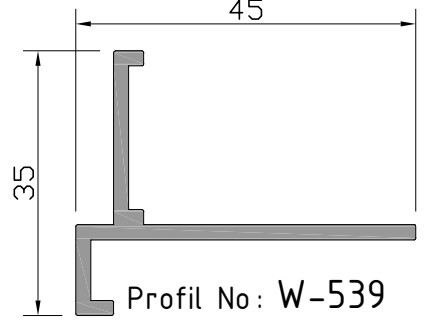

Profil No : W-539

Ağırlık : 460 gr/m

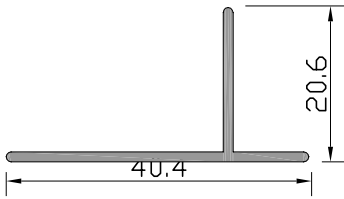

Profil No : W-540

Ağırlık : 208 gr/m

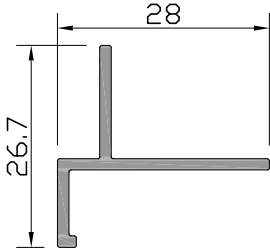

Profil No : W-541

Ağırlık : 219 gr/m

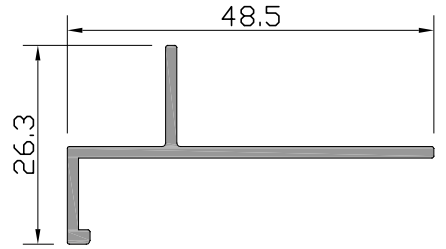

Profil No : W-542

Ağırlık : 306 gr/m

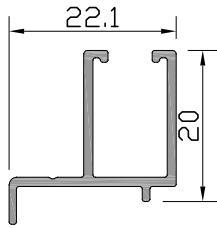

Profil No : W-543 ⚠

Ağırlık : 213 gr/m

⚠ İşaretti profil için satış temsilcilerinizden bilgi alın.

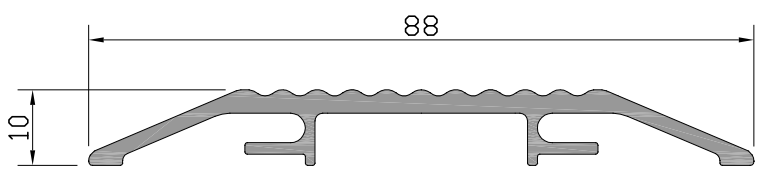

Profil No : W-544

Ağırlık : 728 gr/m

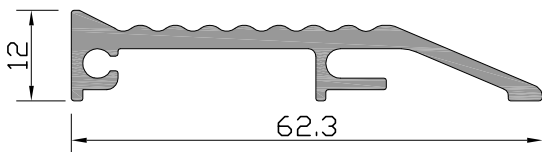

Profil No : W-545

Ağırlık : 578 gr/m

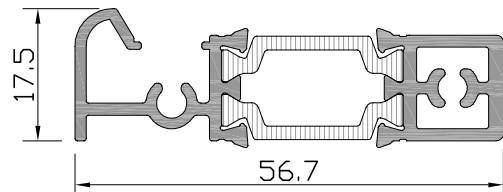

Profil No : W65-555

Ağırlık PVC : 824 gr/m

Ağırlık POLY : 810 gr/m

W6
W 65-2 T YALITIMLI SERİ PROFİLLERİ
W65-2 T INSULATED SERIES

ÜRÜN TEKNİK ÖZELLİKLERİ
PRODUCT'S TECHNICAL FEATURES

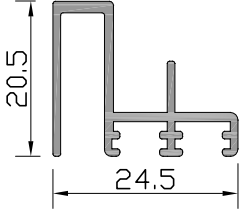

Profil No: W-557
Ağırlık : 260 gr/m

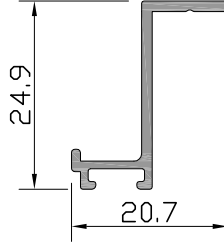

Profil No: W-558
Ağırlık : 173 gr/m

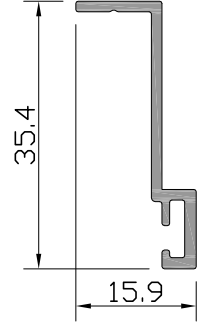

Profil No: W-559
Ağırlık : 216 gr/m

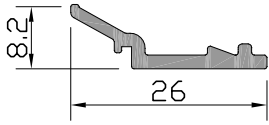

Profil No: W3-507
Ağırlık : 155 gr/m

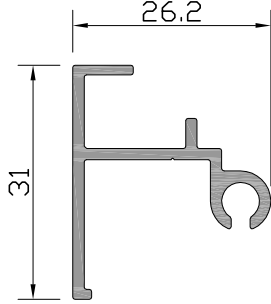

Profil No: W3-508
Ağırlık : 330 gr/m

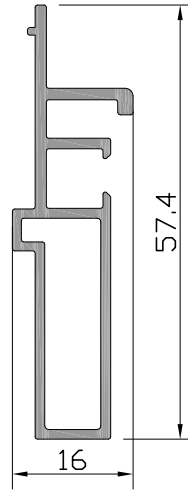

Profil No: W3-511 
Ağırlık : 496 gr/m

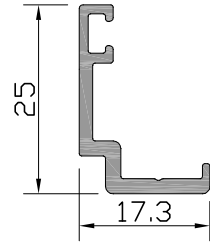

Profil No: W4-504
Ağırlık : 227 gr/m

 İşaretti profil için satış temsilcinizden bilgi alınır.

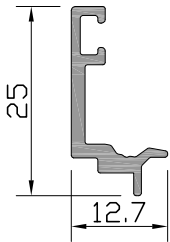

Profil No: W4-505
Ağırlık : 184 gr/m

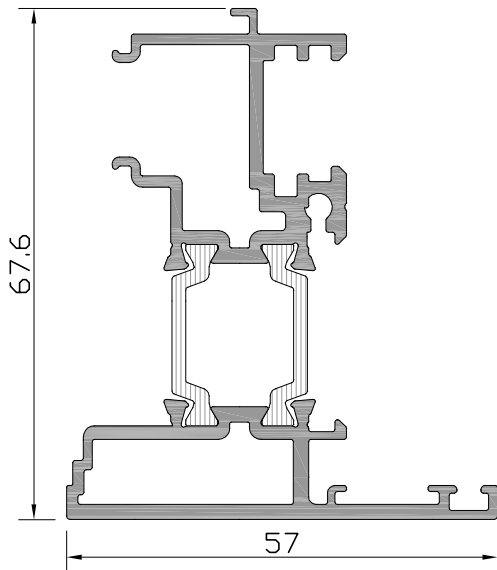

Profil No: W6-501

Ağırlık PVC : 1448	gr/m
Ağırlık POLY : 1433	gr/m

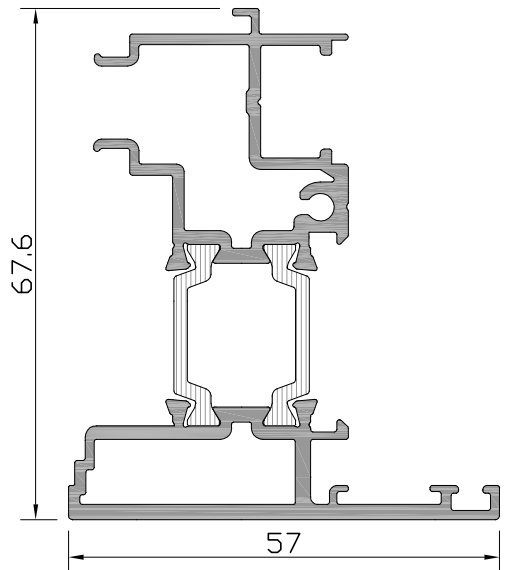

Profil No: W6-501-a

Ağırlık PVC : 1424	gr/m
Ağırlık POLY : 1409	gr/m

W6
W 65-2 T YALITIMLI SERİ PROFİLLERİ
W65-2 T INSULATED SERIES

ÜRÜN TEKNİK ÖZELLİKLERİ
PRODUCT'S TECHNICAL FEATURES

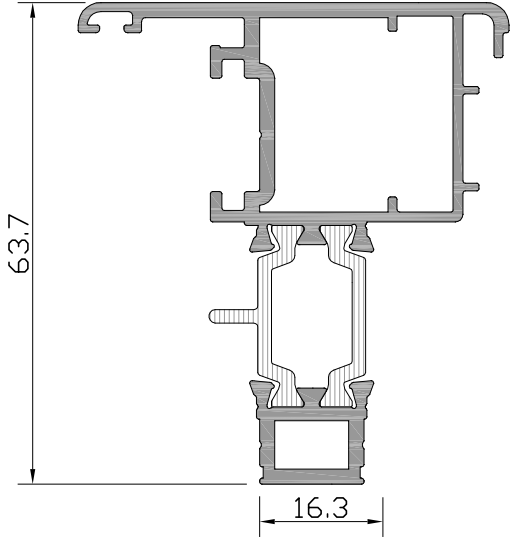

Profil No: **W6-504**

Ağırlık PVC : 1291 gr/m

Ağırlık POLY: 1275 gr/m

W-611-d

SC0309-e

SC0308-e

SC0308-e

SC0309-e

ALTERNATIVE 1

ALTERNATIVE 2

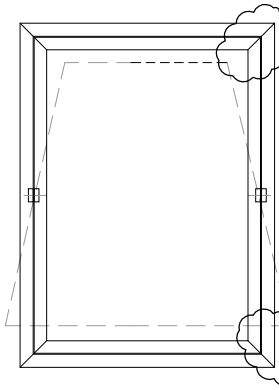

SC0308-e

W-611-d

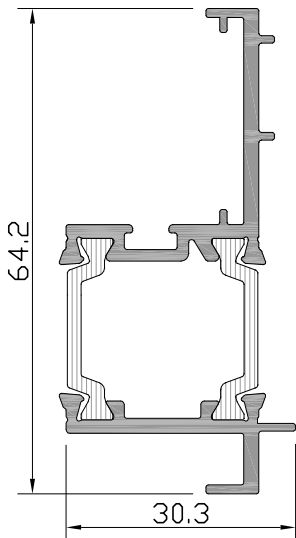

Profil No : **W6-506**

Ağırlık PVC : 844 gr/m

Ağırlık POLY: 829 gr/m

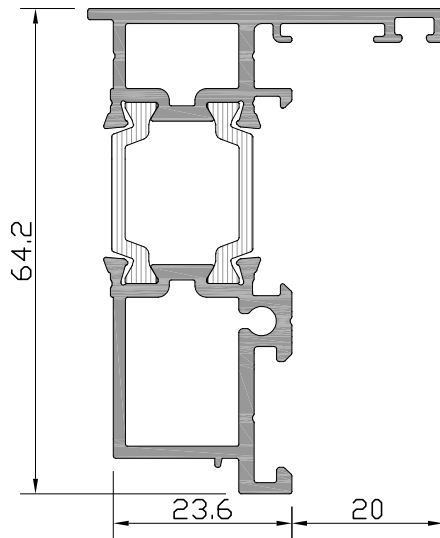

Profil No : **W6-510**

Ağırlık PVC : 1262 gr/m

Ağırlık POLY: 1248 gr/m

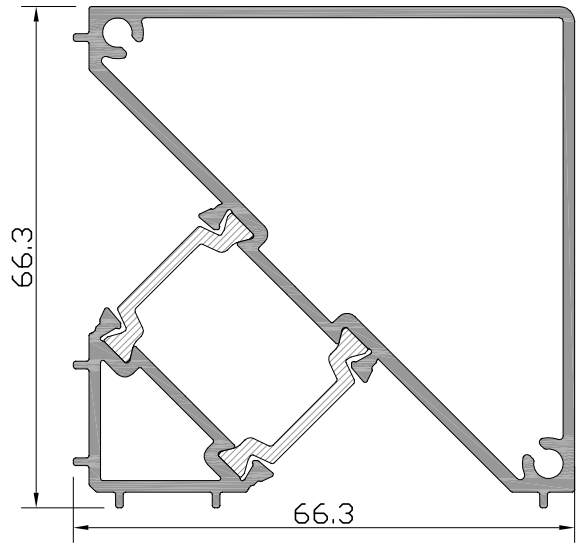

Profil No : **W5-550** ⚠

Ağırlık PVC : 1614 gr/m

Ağırlık POLY: 1599 gr/m

⚠ İşaretili profil için satış temsilcinizden bilgi alınır.

W6
W 65-2 T YALITIMLI SERİ PROFİLLERİ
W65-2 T INSULATED SERIES

ÜRÜN TEKNİK ÖZELLİKLERİ
PRODUCT'S TECHNICAL FEATURES

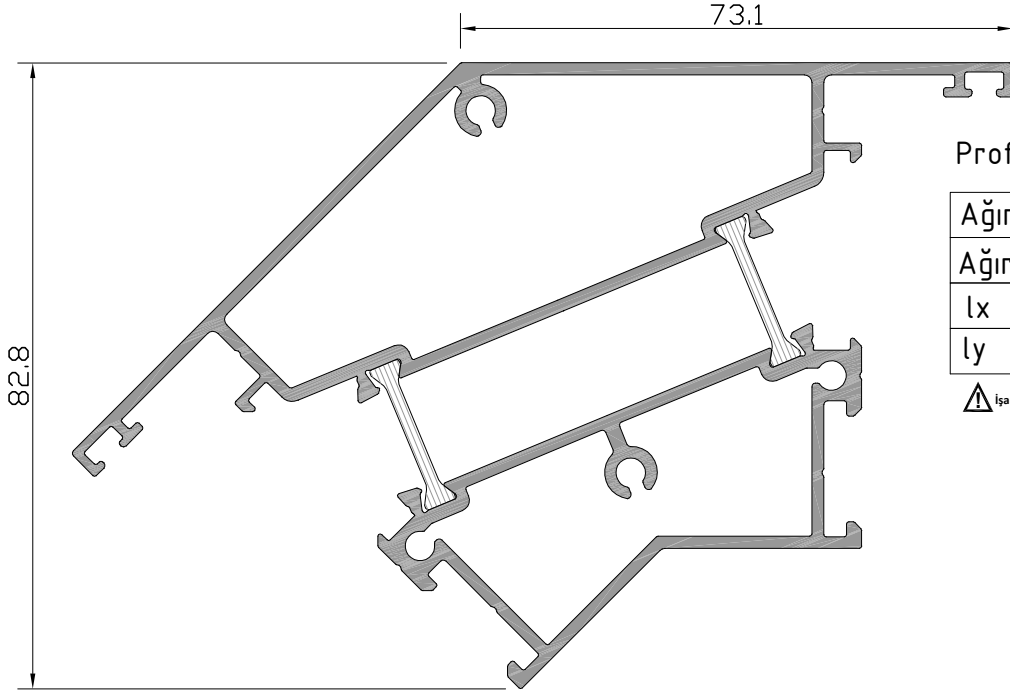

Profil No : W5-551 ⚠

Ağırlık PVC : 2426 gr/m

Ağırlık POLY : 2416 gr/m

lx : 31,50 cm⁴

ly : 75,21 cm⁴

⚠ İşaretti profil için satış temsilcinizden bilgi alınır.

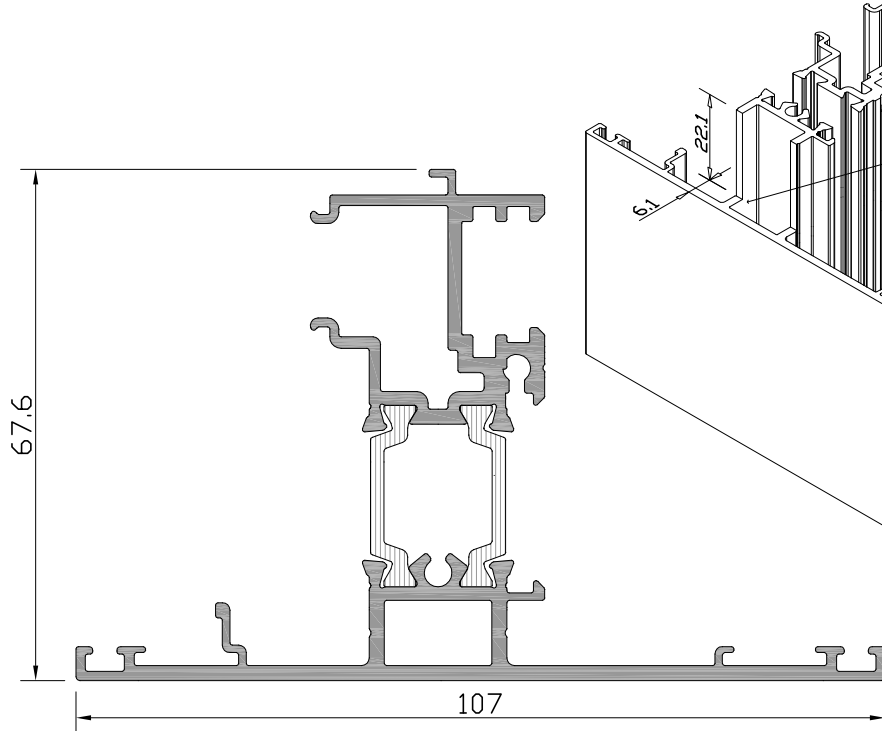

Profil No : W6-512

Ağırlık PVC : 1732 gr/m

Ağırlık POLY : 1718 gr/m

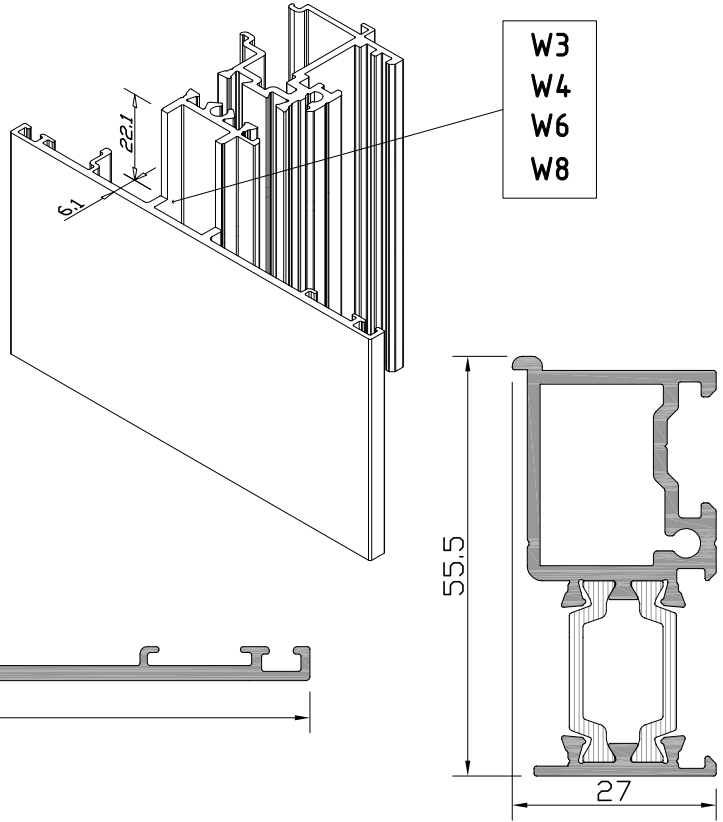

Profil No : W6-513

Ağırlık PVC : 959 gr/m

Ağırlık POLY : 944 gr/m

W6
W 65-2 T YALITIMLI SERİ PROFİLLERİ
W65-2 T INSULATED SERIES

ÜRÜN TEKNİK ÖZELLİKLERİ
PRODUCT'S TECHNICAL FEATURES

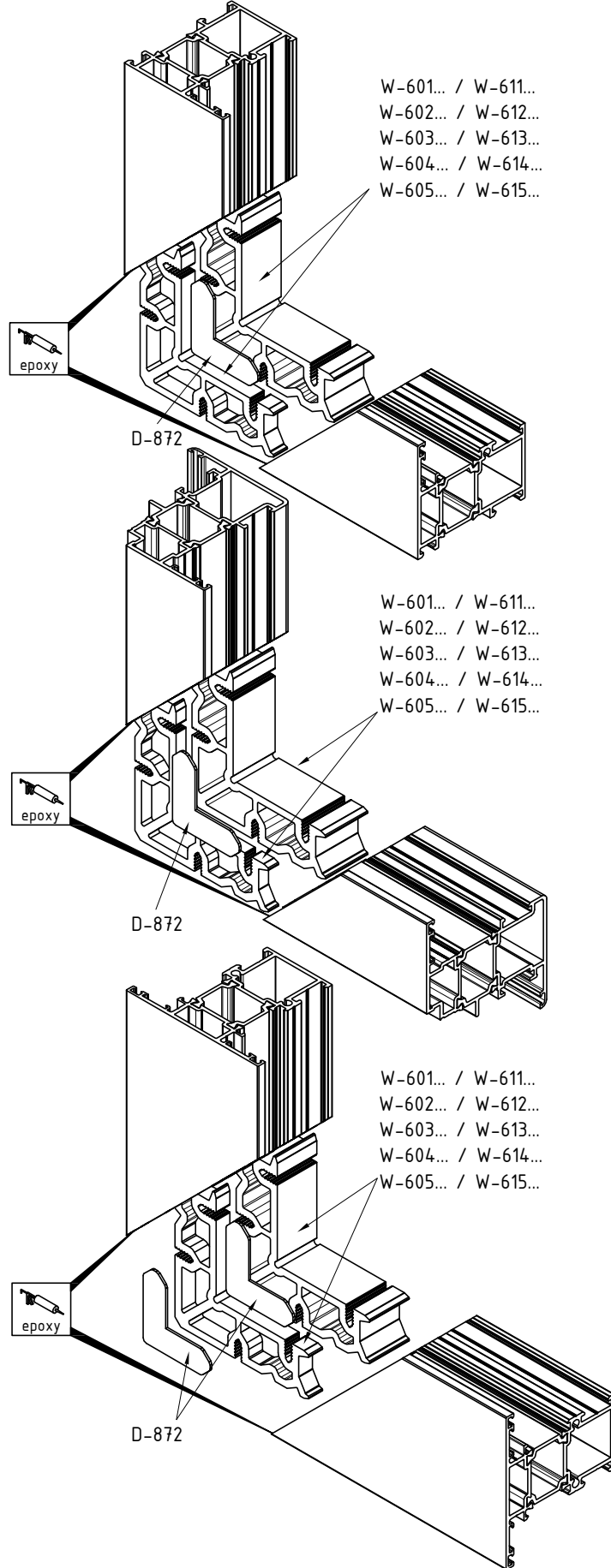

W6
W 65-2 T YALITIMLI SERİ PROFİLLERİ
W65-2 T INSULATED SERIES

ÜRÜN TEKNİK ÖZELLİKLERİ
PRODUCT'S TECHNICAL FEATURES

Profil No: W-601

Ağırlık : 3428 gr/m

Profil No: W-611

Ağırlık : 2520 gr/m

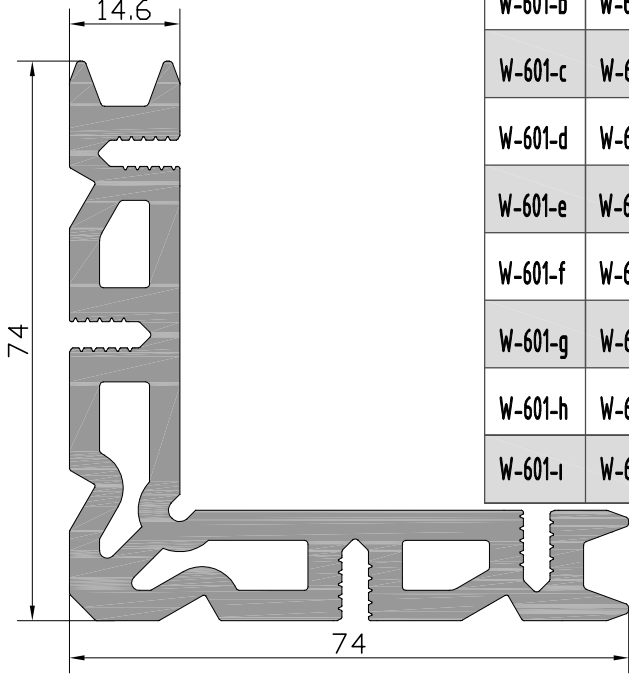

W-601-a	W-611-a	8.2mm	100 adet/pcs
W-601-b	W-611-b	23.6mm	100 adet/pcs
W-601-c	W-611-c	6mm	100 adet/pcs
W-601-d	W-611-d	25.3mm	100 adet/pcs
W-601-e	W-611-e	50.1mm	100 adet/pcs
W-601-f	W-611-f	50.6mm	100 adet/pcs
W-601-g	W-611-g	41.7mm	100 adet/pcs
W-601-h	W-611-h	4.7mm	100 adet/pcs
W-601-i	W-611-i	4.7mm	100 adet/pcs

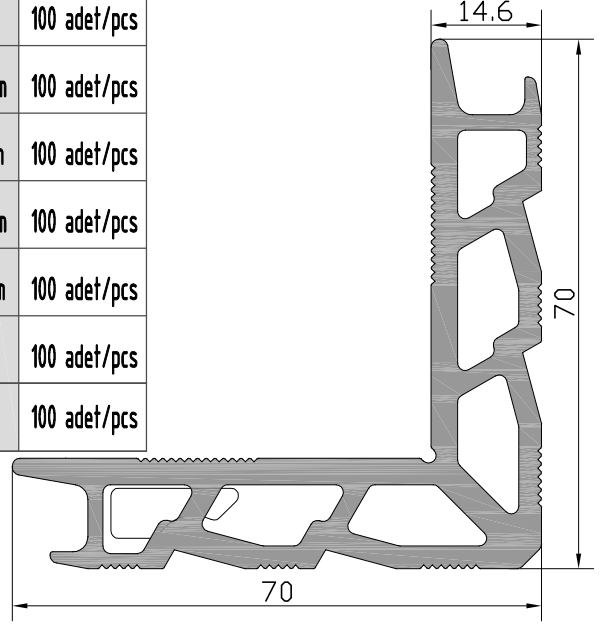

Profil No: W-601\2 ⚠

Ağırlık : 4285 gr/m

⚠ İşaretli profil için satış temsilcinizden bilgi alınız.

Profil No: W-611\2

Ağırlık : 2749 gr/m

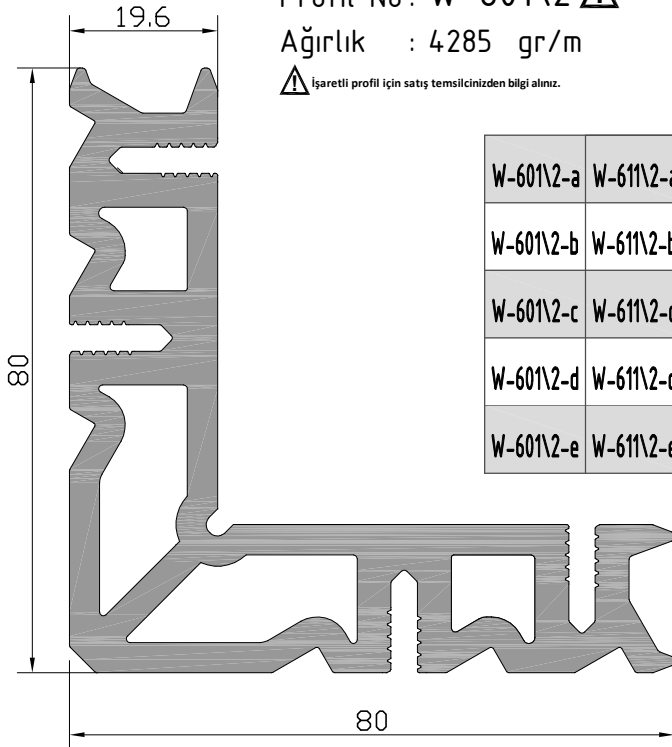

W-601\2-a	W-611\2-a	6mm	100 adet/pcs
W-601\2-b	W-611\2-b	25.3mm	100 adet/pcs
W-601\2-c	W-611\2-c	8.2mm	100 adet/pcs
W-601\2-d	W-611\2-d	23.6mm	100 adet/pcs
W-601\2-e	W-611\2-e	50.1mm	100 adet/pcs

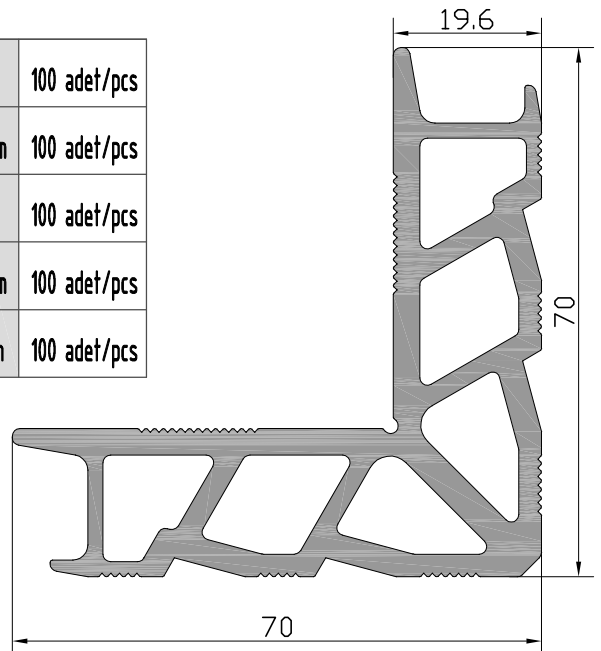

W6
W 65-2 T YALITIMLI SERİ PROFİLLERİ
W65-2 T INSULATED SERIES

ÜRÜN TEKNİK ÖZELLİKLERİ
PRODUCT'S TECHNICAL FEATURES

Profil No: **W-602**

Ağırlık : 4380 gr/m

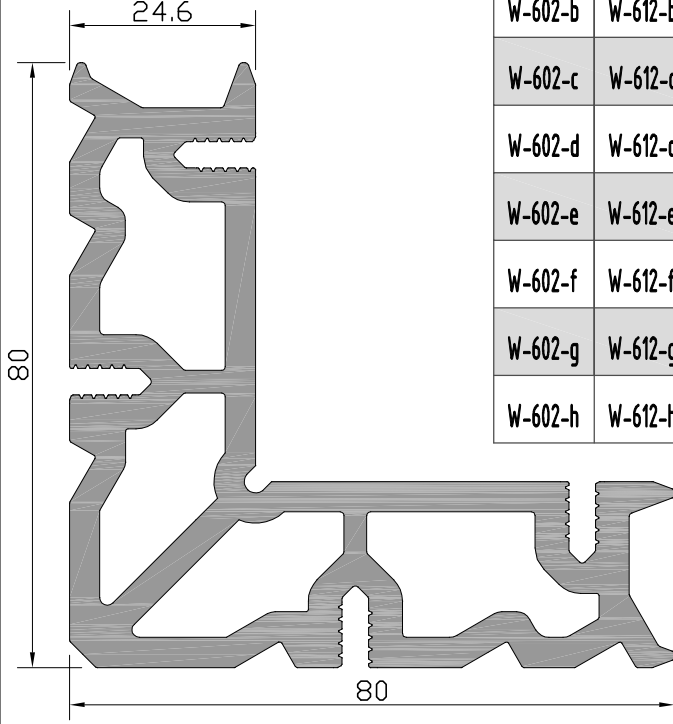

W-602-a	W-612-a	8.2mm	100 adet/pcs
W-602-b	W-612-b	23.6mm	100 adet/pcs
W-602-c	W-612-c	6mm	100 adet/pcs
W-602-d	W-612-d	25.3mm	100 adet/pcs
W-602-e	W-612-e	50.1mm	100 adet/pcs
W-602-f	W-612-f	50.6mm	100 adet/pcs
W-602-g	W-612-g	4.7mm	100 adet/pcs
W-602-h	W-612-h	41.8mm	100 adet/pcs

Profil No: **W-612**

Ağırlık : 3524 gr/m

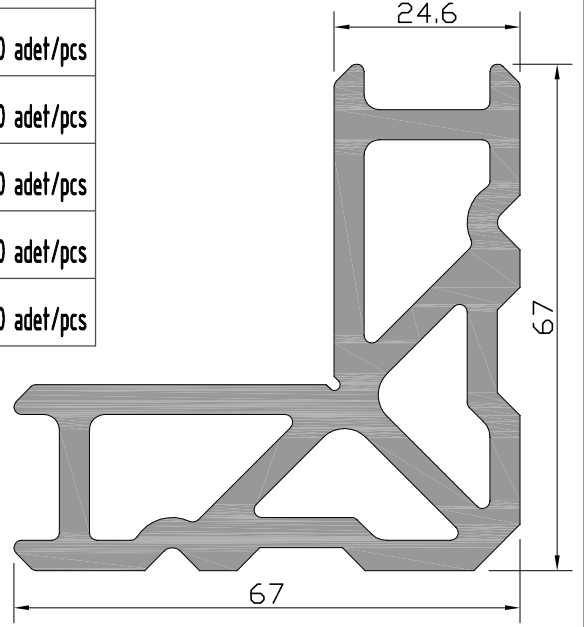

Profil No: **W-603**

Ağırlık : 4871 gr/m

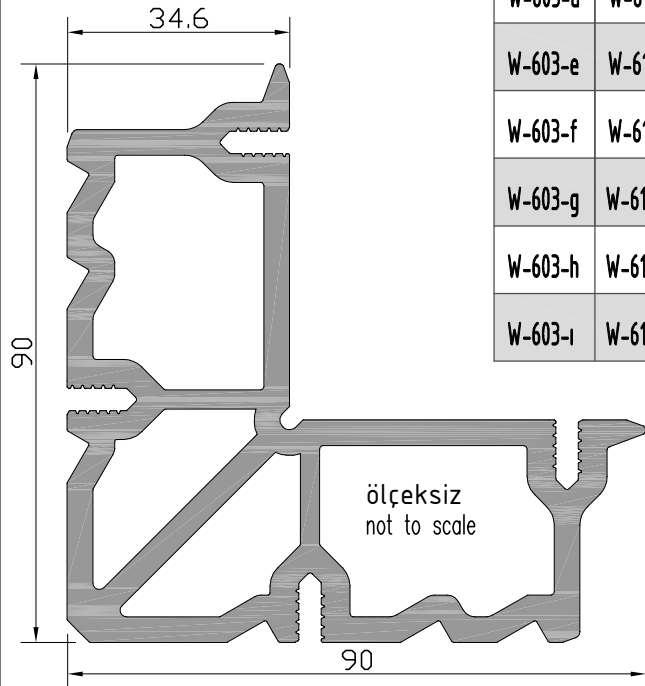

W-603-a	W-613-a	8.2mm	50 adet/pcs
W-603-b	W-613-b	23.6mm	50 adet/pcs
W-603-c	W-613-c	6mm	50 adet/pcs
W-603-d	W-613-d	25.3mm	50 adet/pcs
W-603-e	W-613-e	50.1mm	50 adet/pcs
W-603-f	W-613-f	5.3mm	50 adet/pcs
W-603-g	W-613-g	4.7mm	50 adet/pcs
W-603-h	W-613-h	7.5mm	50 adet/pcs
W-603-ı	W-613-ı	41.8mm	50 adet/pcs

Profil No: **W-613**

Ağırlık : 3945 gr/m

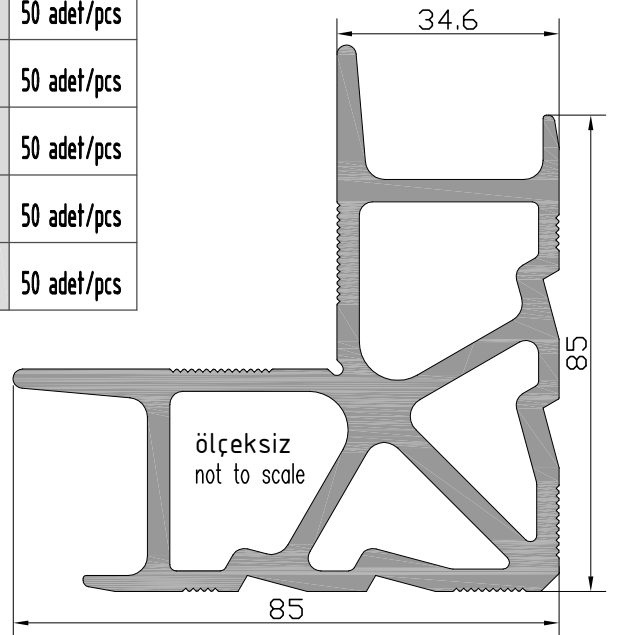

W6
W 65-2 T YALITIMLI SERİ PROFİLLERİ
W65-2 T INSULATED SERIES

ÜRÜN TEKNİK ÖZELLİKLERİ
PRODUCT'S TECHNICAL FEATURES

Profil No : W-604
Ağırlık : 5539 gr/m

W-604-a	W-614-a	6mm	25 adet/pcs
W-604-b	W-614-b	25.3mm	25 adet/pcs
W-604-c	W-614-c	23.4mm	25 adet/pcs
W-604-d	W-614-d	14mm	25 adet/pcs
W-604-e	W-614-e	50.1mm	25 adet/pcs
W-604-f	W-614-f	50.6mm	25 adet/pcs
W-604-g	W-614-g	42.1mm	25 adet/pcs

W-604-h	W-614-h	20mm	25 adet/pcs
W-604-ı	W-614-ı	5.3mm	25 adet/pcs
W-604-j	W-614-j	43.3mm	25 adet/pcs
W-604-k	W-614-k	7.5mm	25 adet/pcs
W-604-l	W-614-l	18.6mm	25 adet/pcs
W-604-m	W-614-m	11.9mm	25 adet/pcs
W-604-n	W-614-n	41.8mm	25 adet/pcs
W-604-o	W-614-o	8.5mm	25 adet/pcs

Profil No : W-614
Ağırlık : 5318 gr/m

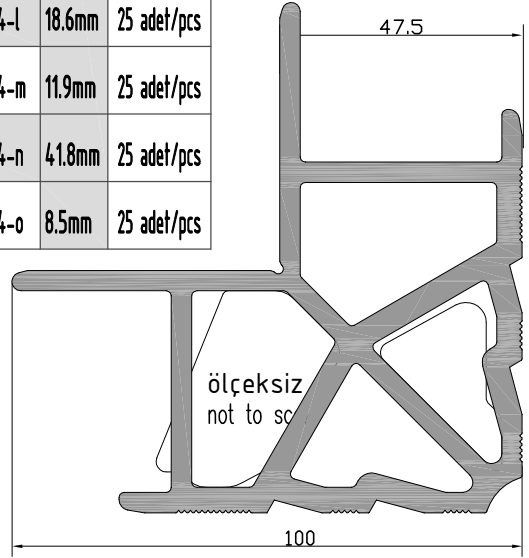
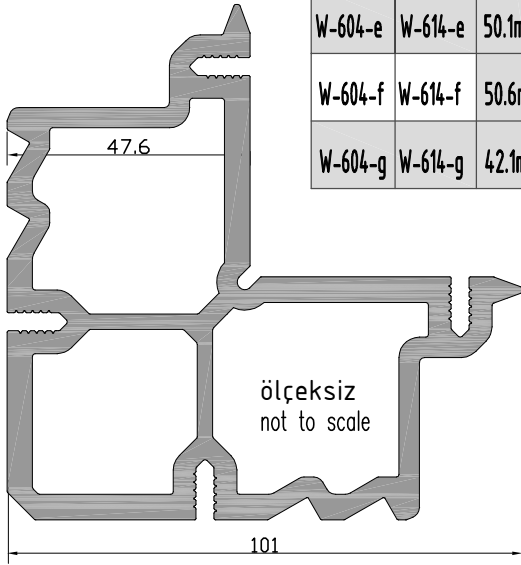

Profil No : W-605
Ağırlık : 6063 gr/m

W-605-a	W-615-a	6mm	25 adet/pcs
W-605-b	W-615-b	25.3mm	25 adet/pcs
W-605-c	W-615-c	23.3mm	25 adet/pcs
W-605-d	W-615-d	14mm	25 adet/pcs
W-605-e	W-615-e	50.1mm	25 adet/pcs
W-605-f	W-615-f	50.6mm	25 adet/pcs

W-605-g	W-615-g	42.1mm	25 adet/pcs
W-605-h	W-615-h	18.6mm	25 adet/pcs
W-605-ı	W-615-ı	11.9mm	25 adet/pcs
W-605-j	W-615-j	4.7mm	25 adet/pcs
W-605-k	W-615-k	41.8mm	25 adet/pcs

Profil No : W-615
Ağırlık : 6313 gr/m

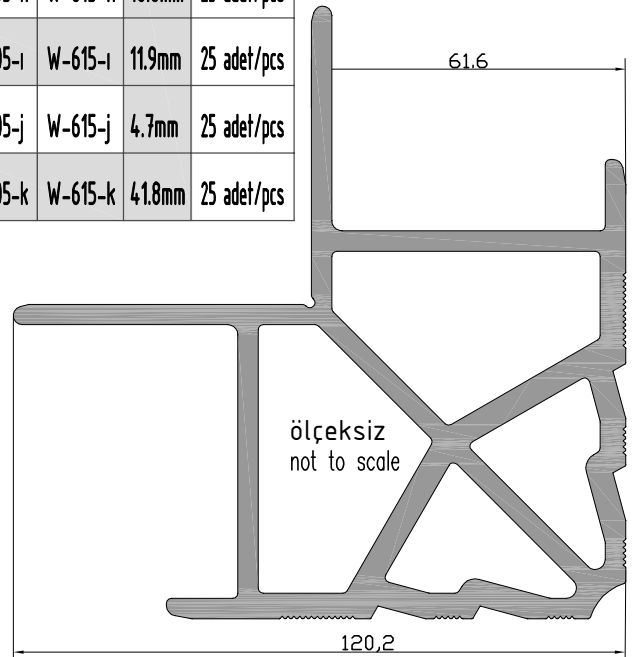
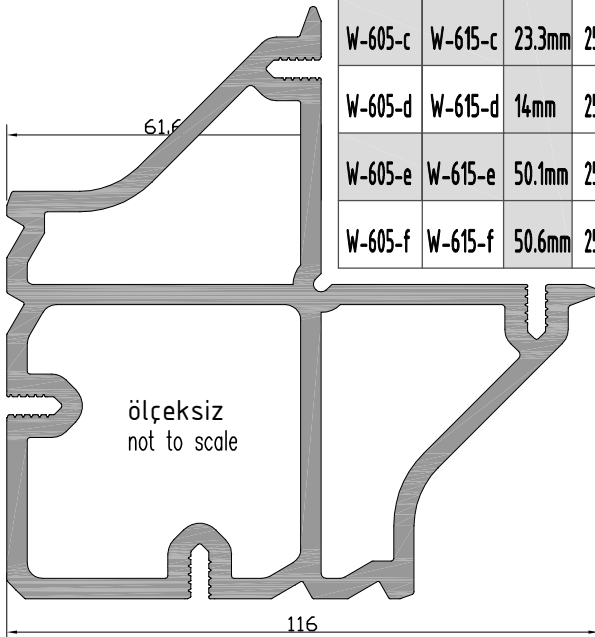

W6
W 65-2 T YALITIMLI SERİ PROFİLLERİ
W65-2 T INSULATED SERIES

ORTA KAYIT BAĞLANTI
T - CONNECTOR

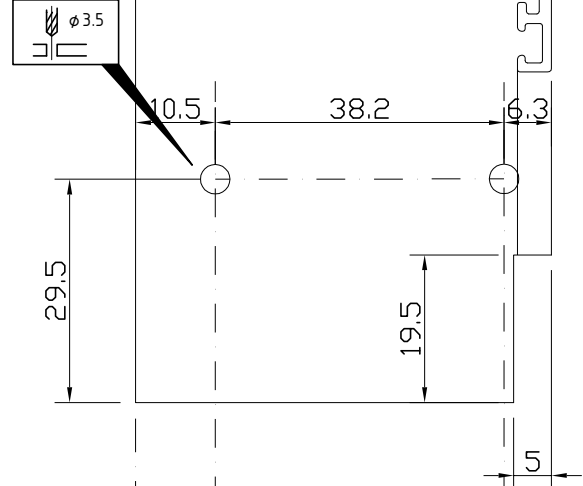
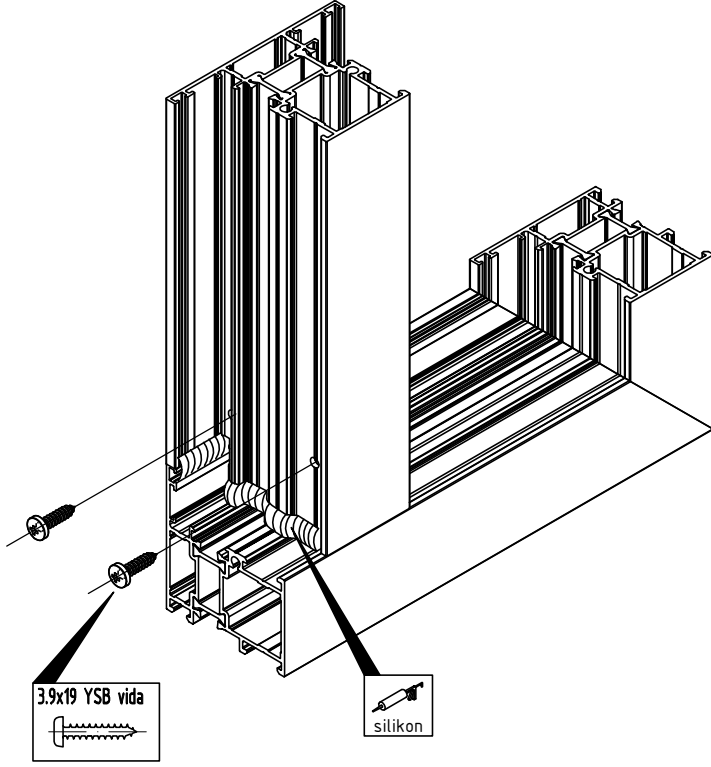

ALTERNATİF 3
ALTERNATIVE 3

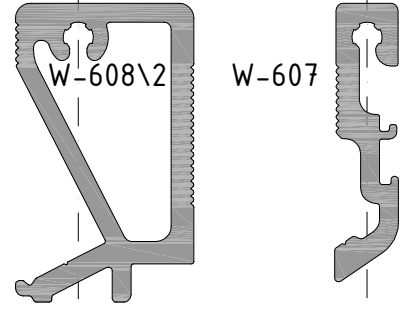

ALTERNATİF 1
ALTERNATIVE 1

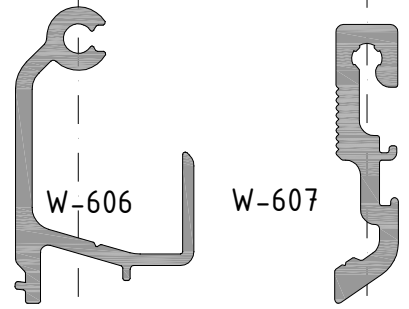

ALTERNATİF 2
ALTERNATIVE 2

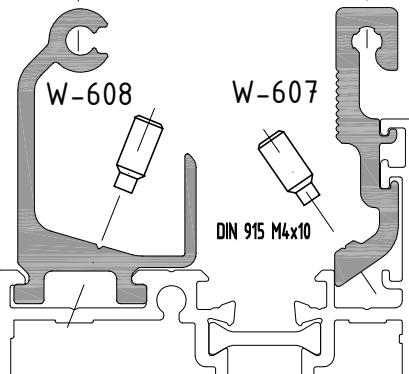

W6
W 65-2 T YALITIMLI SERİ PROFİLLERİ
W65-2 T INSULATED SERIES

ÜRÜN TEKNİK ÖZELLİKLERİ
PRODUCT'S TECHNICAL FEATURES

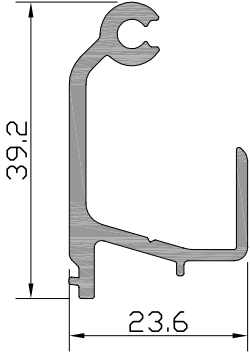

Profil No : W-606
Ağırlık : 482gr/m

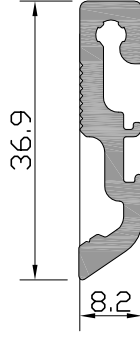

Profil No : W-607
Ağırlık : 431 gr/m

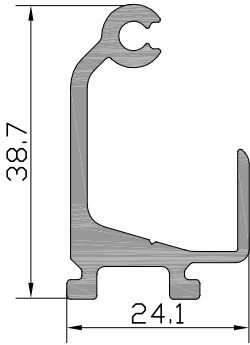

Profil No : W-608
Ağırlık : 583 gr/m

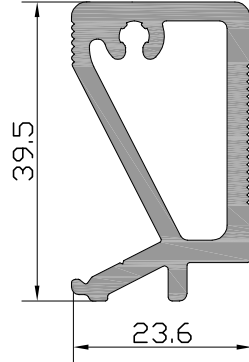

Profil No : W-608\2
Ağırlık : 904 gr/m

W-606-a	W-607-a	W-608-a	W-608\2-a	14.6mm	100 adet/pcs
W-606-b	W-607-b	W-608-b	W-608\2-b	24.6mm	100 adet/pcs
W-606-c	W-607-c	W-608-c	W-608\2-c	34.6mm	100 adet/pcs
W-606-d	W-607-d	W-608-d	W-608\2-d	55.6mm	100 adet/pcs
W-606-e	W-607-e	W-608-e	W-608\2-e	80.3mm	100 adet/pcs
W-606-f	W-607-f	W-608-f	W-608\2-f	110.6mm	100 adet/pcs
W-606-g	W-607-g	W-608-g	W-608\2-g	19.6mm	100 adet/pcs
W-606-h	W-607-h	W-608-h	W-608\2-h	9.7mm	100 adet/pcs
W-606-ı	W-607-ı	W-608-ı	W-608\2-ı	66.6mm	100 adet/pcs
W-606-j	W-607-j	W-608-j	W-608\2-j	53.4mm	100 adet/pcs
W-606-k	W-607-k	W-608-k	W-608\2-k	115.6mm	100 adet/pcs
W-606-l	W-607-l	W-608-l	W-608\2-l	85.6mm	100 adet/pcs
W-606-m	W-607-m	W-608-m	W-608\2-m	45.6mm	100 adet/pcs

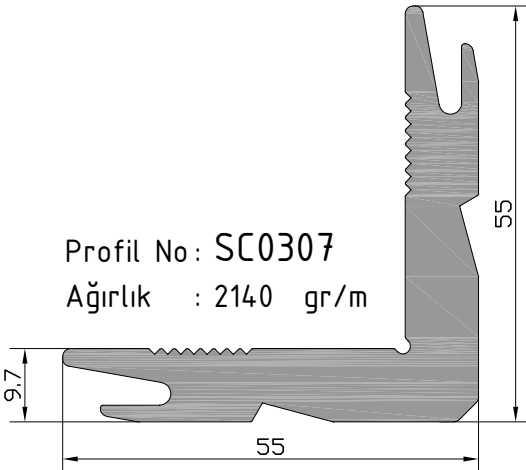

Profil No : SC0307
Ağırlık : 2140 gr/m

SC0307-a	10.25mm	100 adet/pcs	SC0307-f	25.6mm	100 adet/pcs
SC0307-b	27mm	100 adet/pcs	SC0307-g	6mm	100 adet/pcs
SC0307-c	8.5mm	100 adet/pcs	SC0307-h	4.7mm	100 adet/pcs
SC0307-d	24mm	100 adet/pcs	SC0307-ı	26.28mm	100 adet/pcs
SC0307-e	6.3mm	100 adet/pcs	SC0307-j	29.5mm	100 adet/pcs

W6
W 65-2 T YALITIMLI SERİ PROFİLLERİ
W65-2 T INSULATED SERIES

ÜRÜN TEKNİK ÖZELLİKLERİ
PRODUCT'S TECHNICAL FEATURES

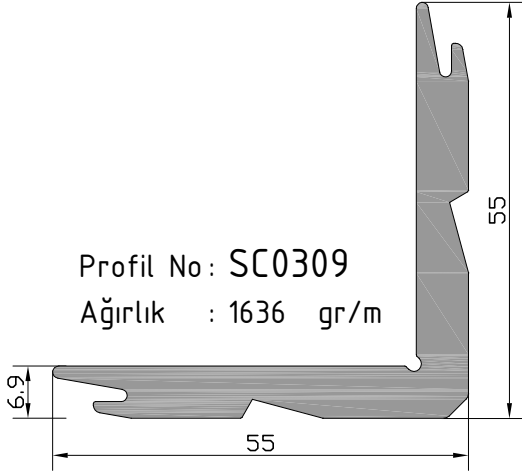

SC0309-a	6.5mm	100 adet/pcs
SC0309-b	8.5mm	100 adet/pcs
SC0309-c	18.9mm	100 adet/pcs
SC0309-d	20mm	100 adet/pcs
SC0309-e	25.3mm	100 adet/pcs

SC0309-f	4.7mm	100 adet/pcs
SC0309-g	54.2mm	100 adet/pcs
SC0309-h	23.8mm	100 adet/pcs
SC0309-i	48.2mm	100 adet/pcs

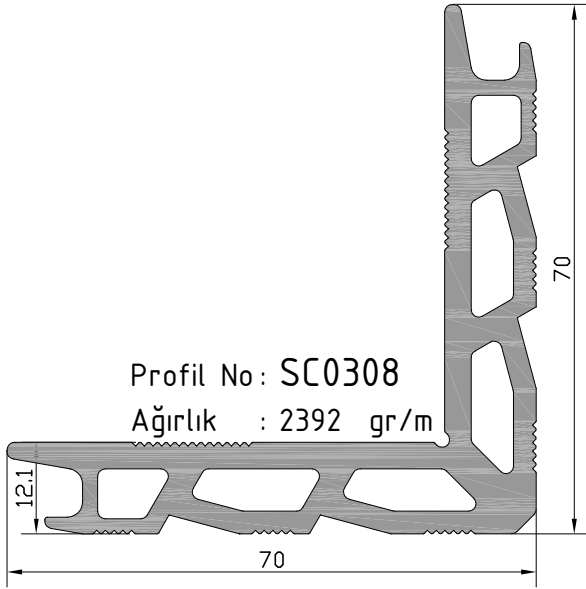

SC0308-a	25.68mm	100 adet/pcs
SC0308-b	29.74mm	100 adet/pcs
SC0308-c	24.36mm	100 adet/pcs
SC0308-d	10.30mm	100 adet/pcs
SC0308-e	6.70mm	100 adet/pcs
SC0308-f	23mm	100 adet/pcs

W6
W 65-2T YALITIMLI SERİ
W65-2T INSULATED SERIES

YAN BITİM DETAYI
WALL CONNECTION DETAIL

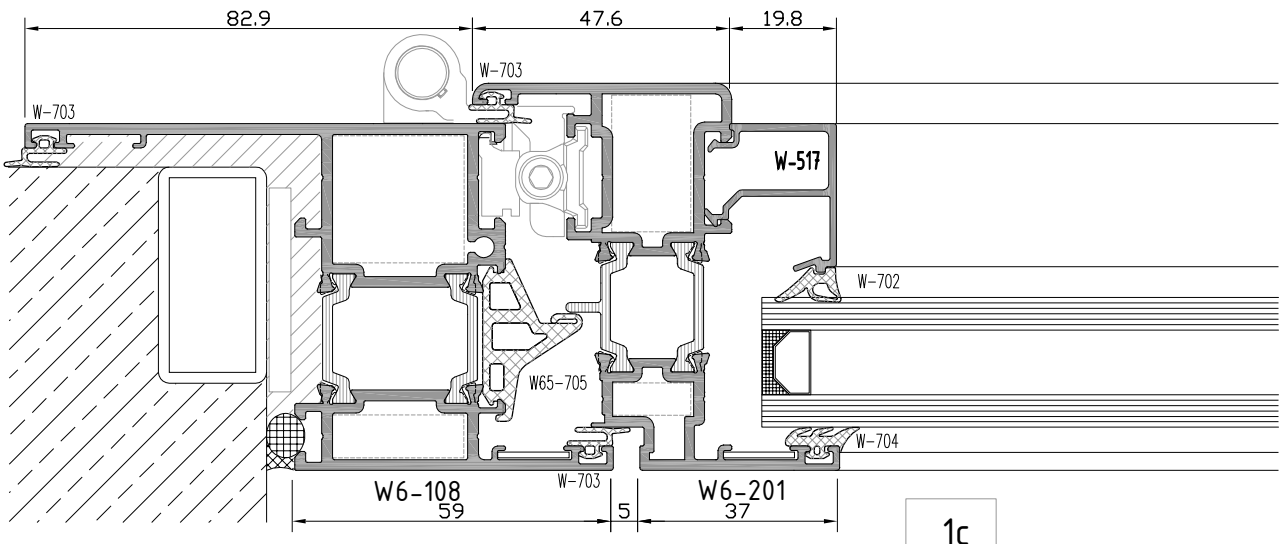
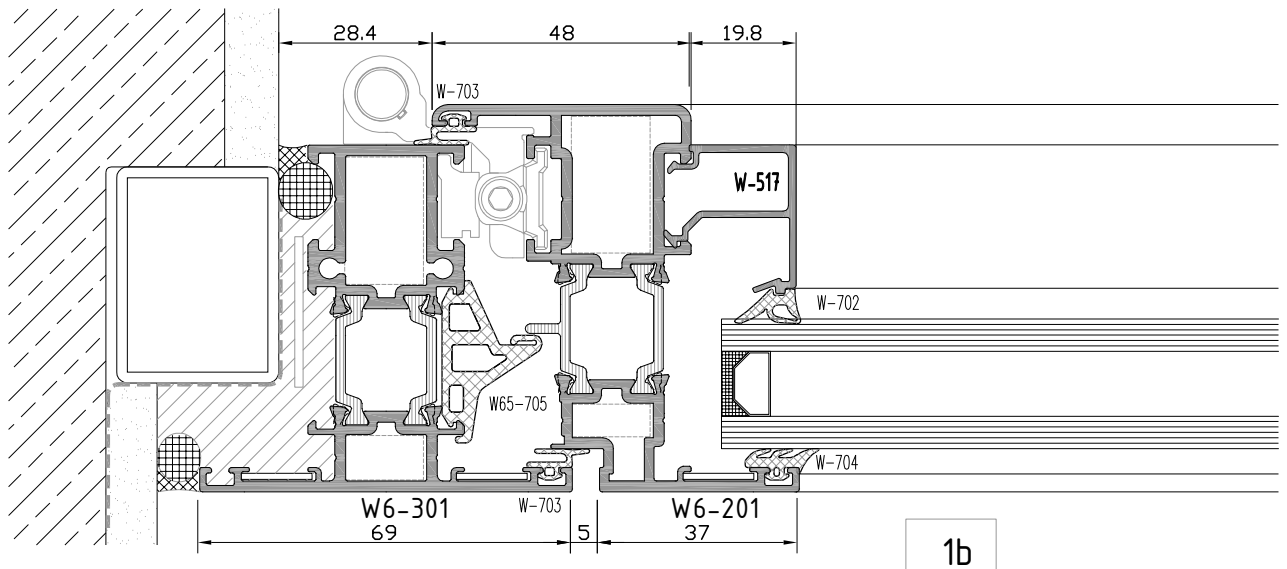
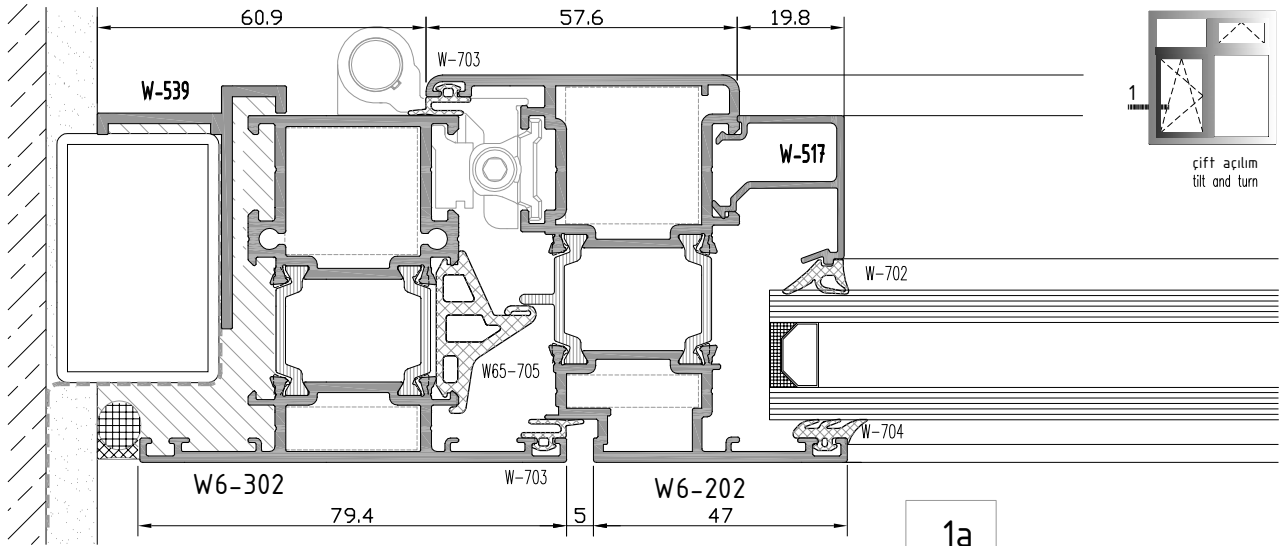

not to scale

W6
W 65-2T YALITIMLI SERİ
W65-2T INSULATED SERIES

YAN BİTİM DETAYI
WALL CONNECTION DETAIL

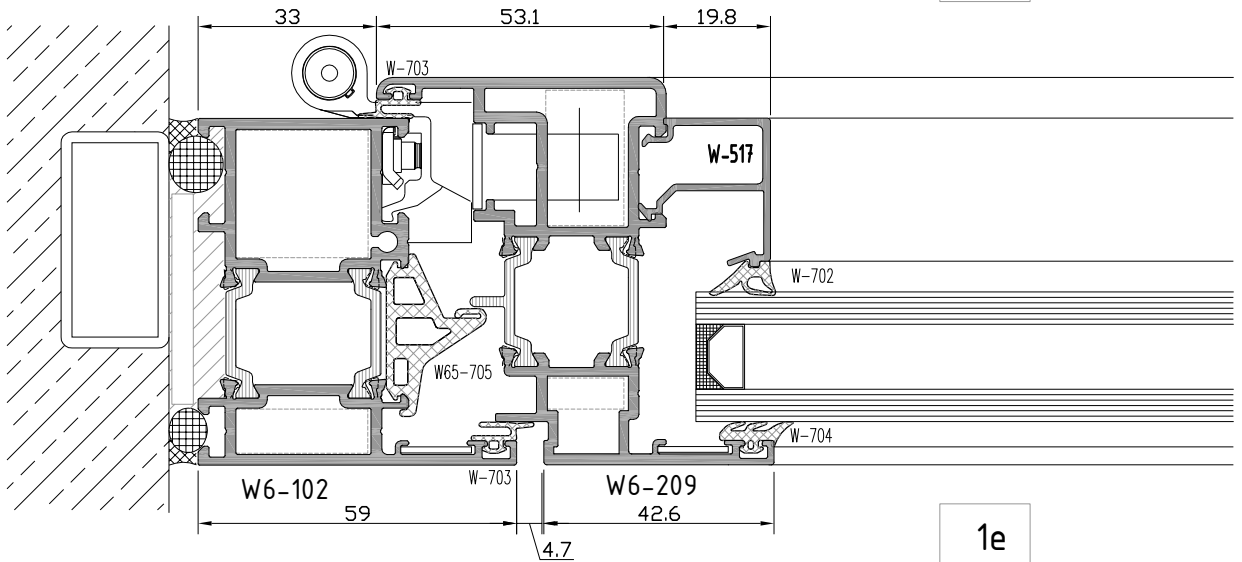
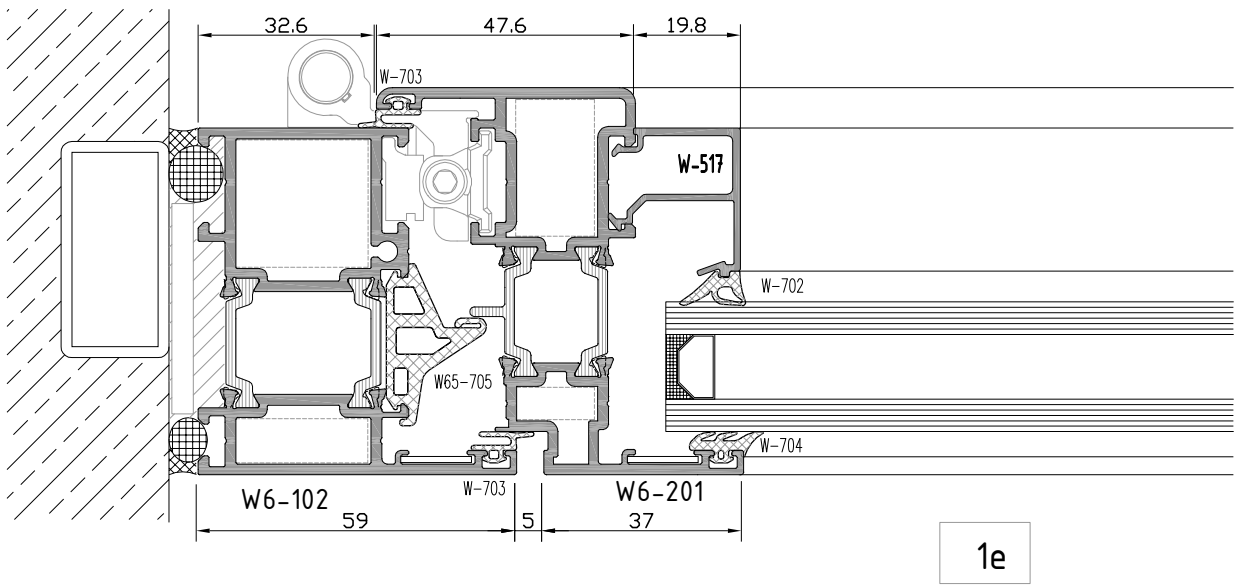
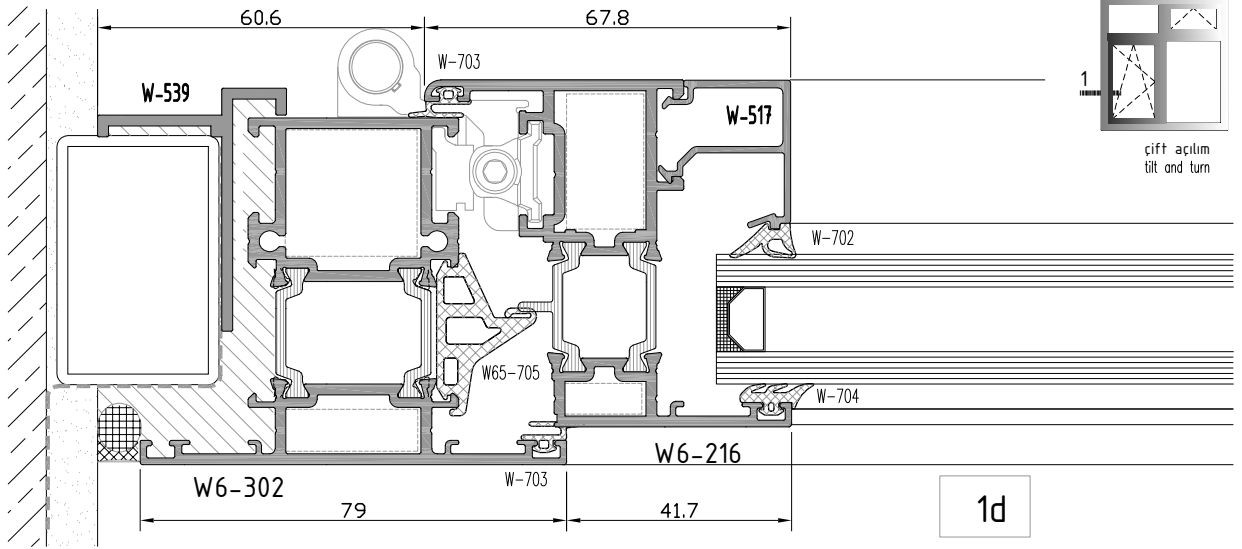

not to scale

W6
W 65-2T YALITIMLI SERİ
W65-2T INSULATED SERIES

ORTA KAYIT DETAYI
MULLION DETAIL

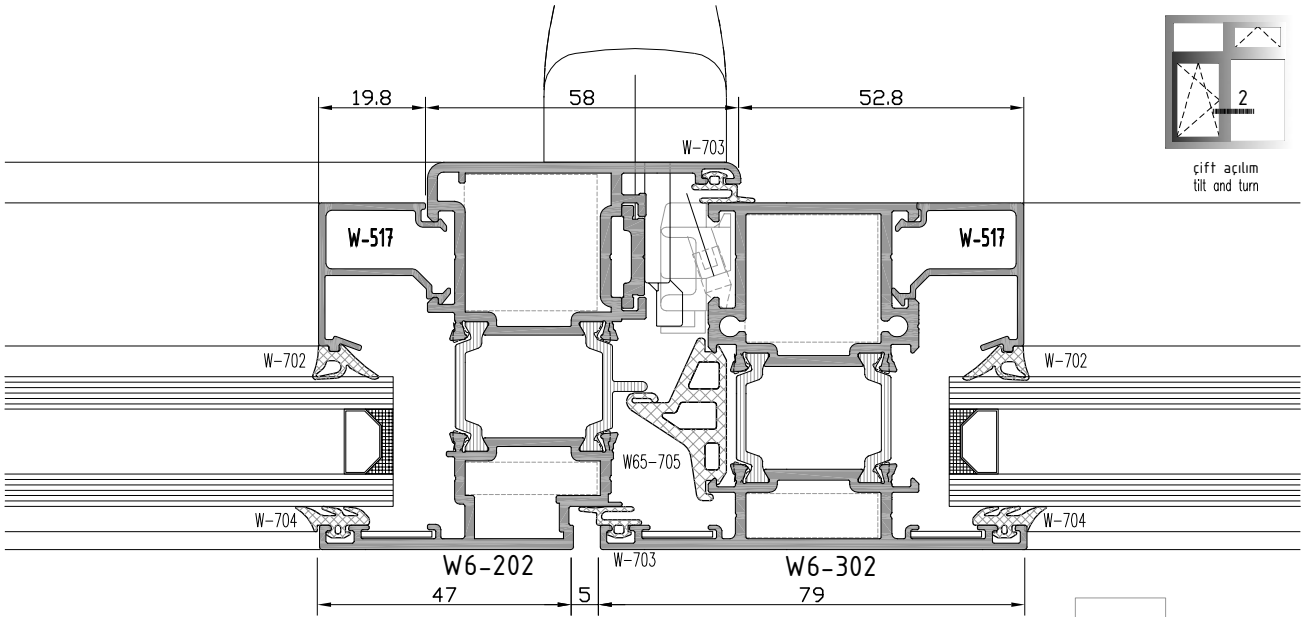

2a

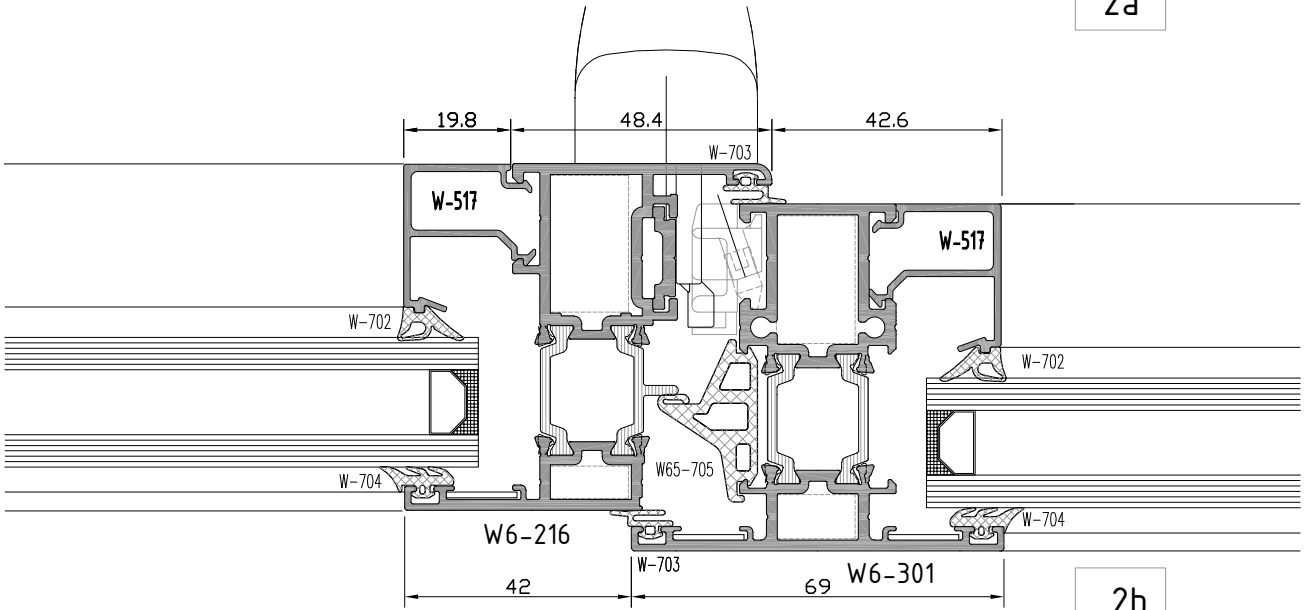

2b

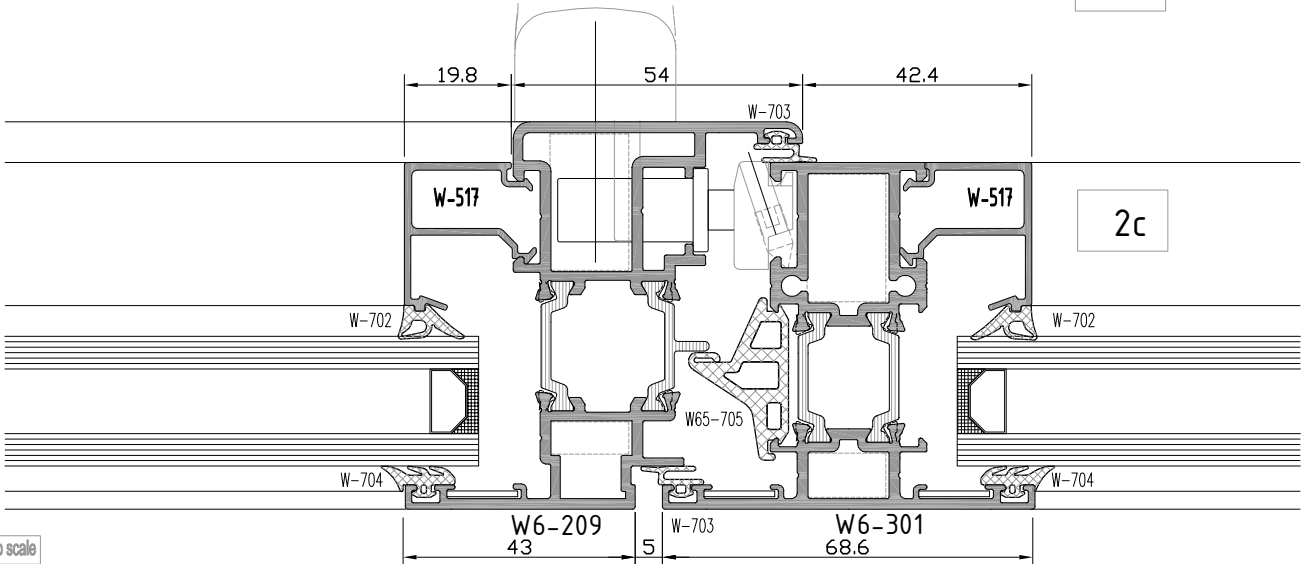

2c

not to scale

W6
W 65-2T YALITIMLI SERİ
W65-2T INSULATED SERIES

YAN BİTİM DETAYI
WALL CONNECTION DETAIL

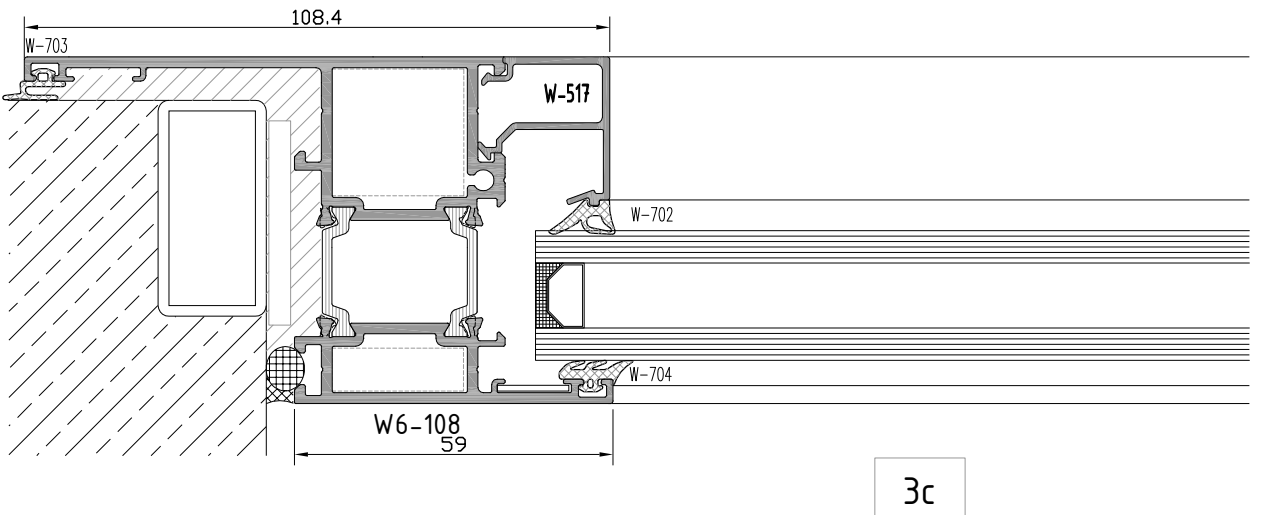
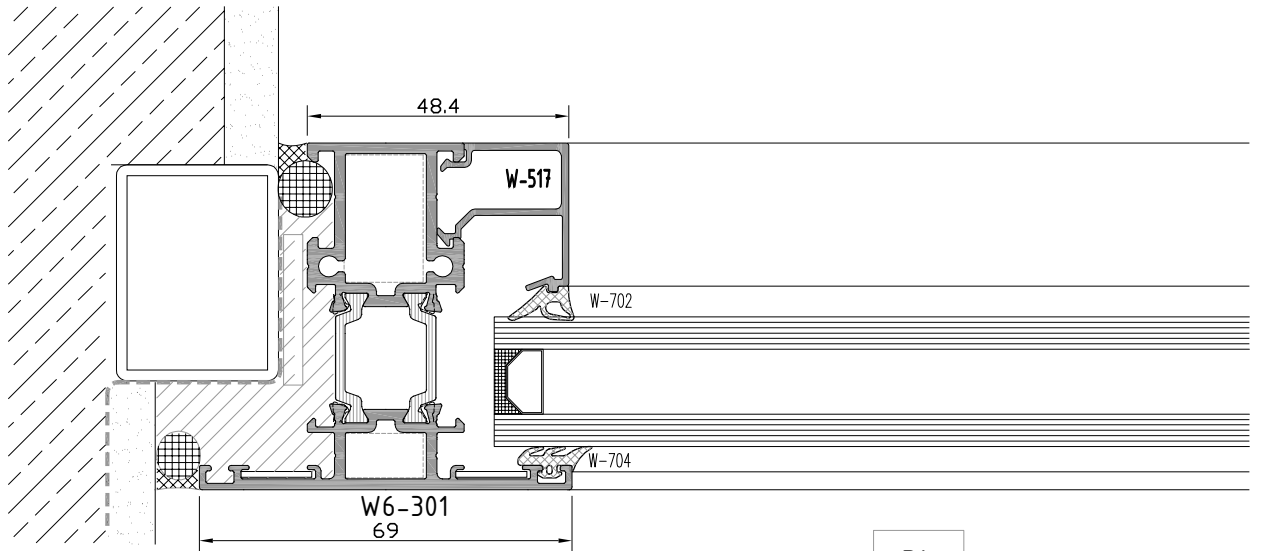
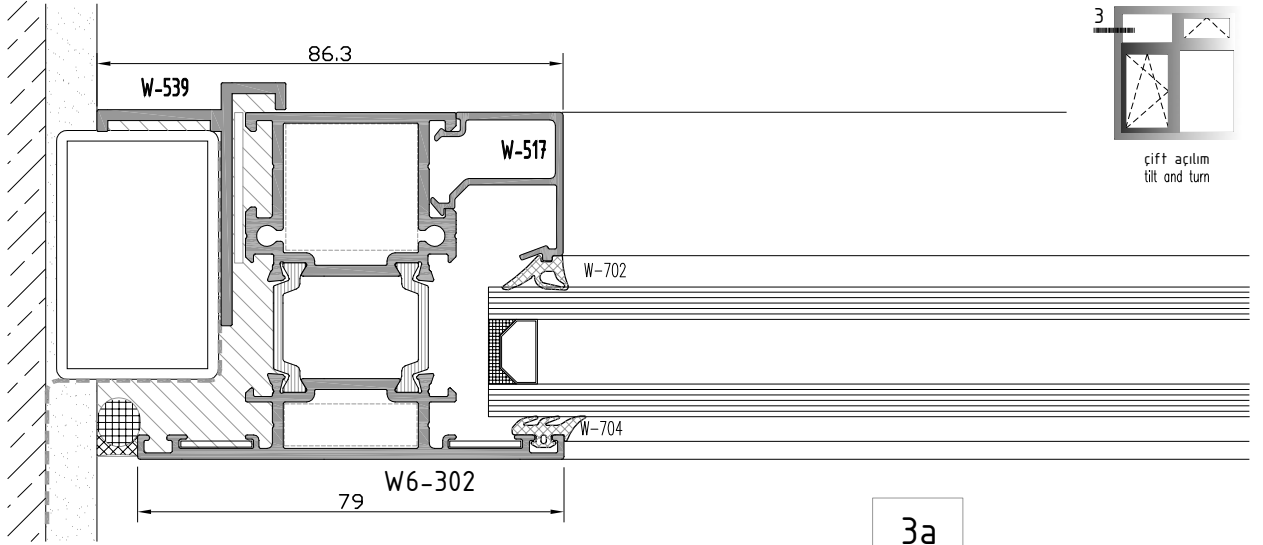

not to scale

W6
W 65-2T YALITIMLI SERİ
W65-2T INSULATED SERIES

ÜST BİTİM DETAYI
TOP EDGE - DETAIL

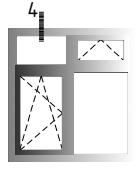

cift açilim
tilt and turn

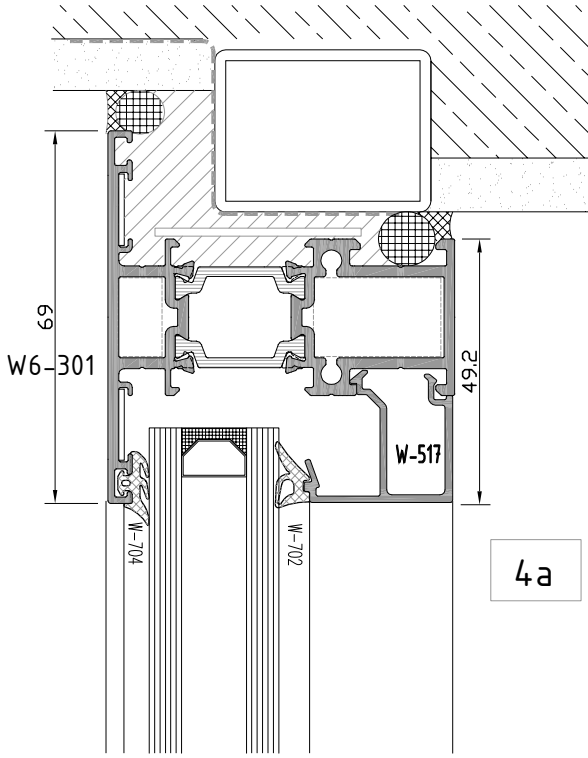

4a

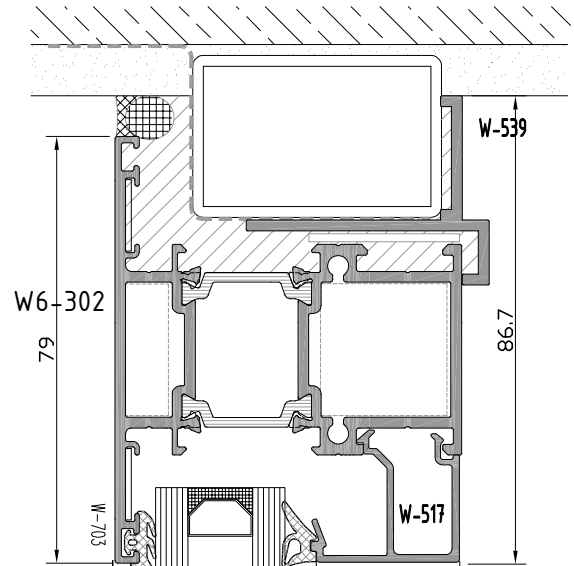

4c

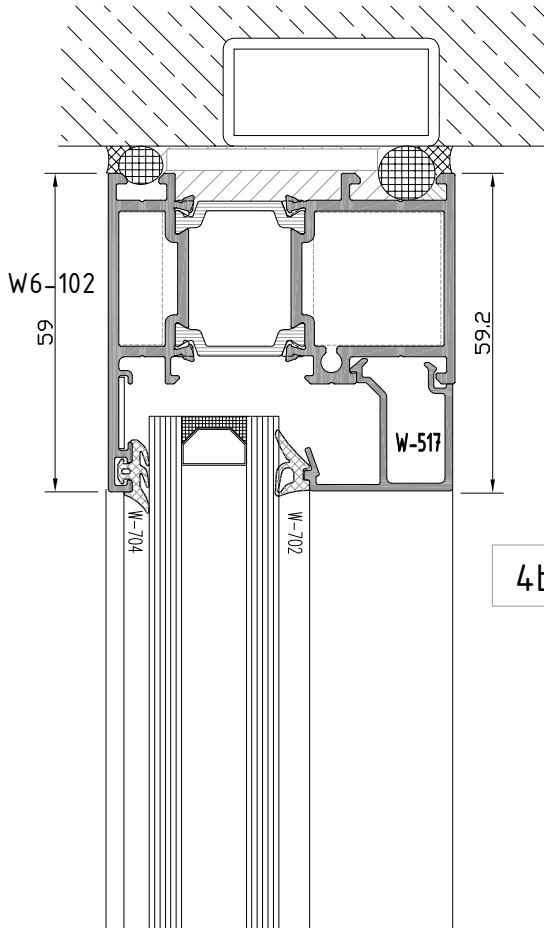

4b

not to scale

W6
W 65-2T YALITIMLI SERİ
 W65-2T INSULATED SERIES

ORTA KAYIT DETAYI
 MULLION DETAIL

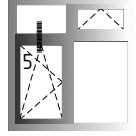

çift açılım
 tilt and turn

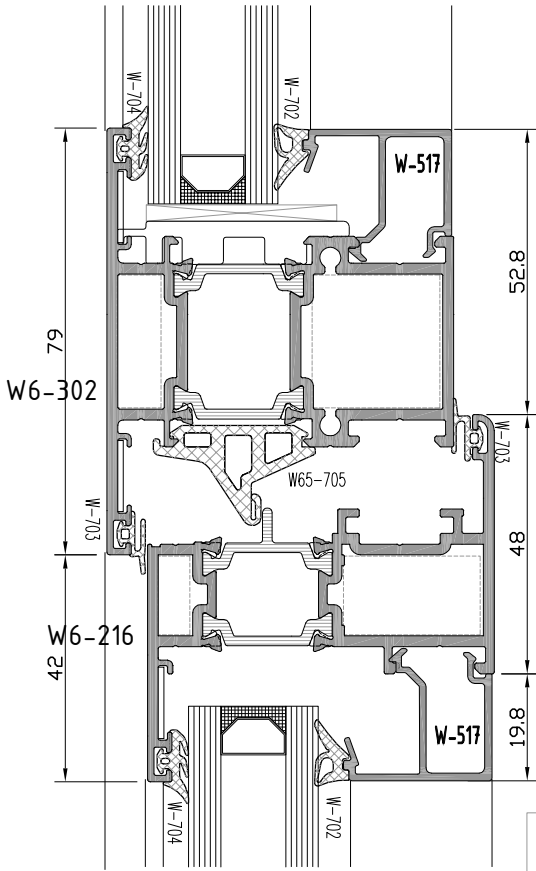

5a

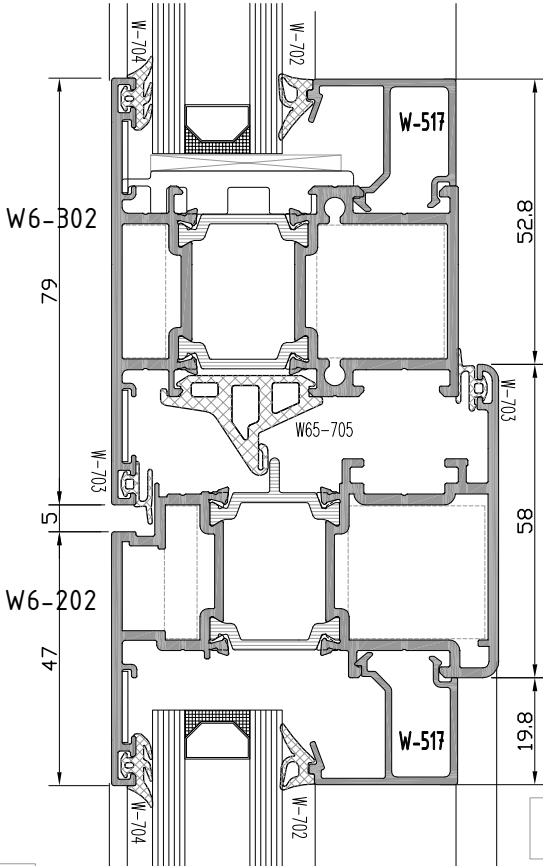

5b

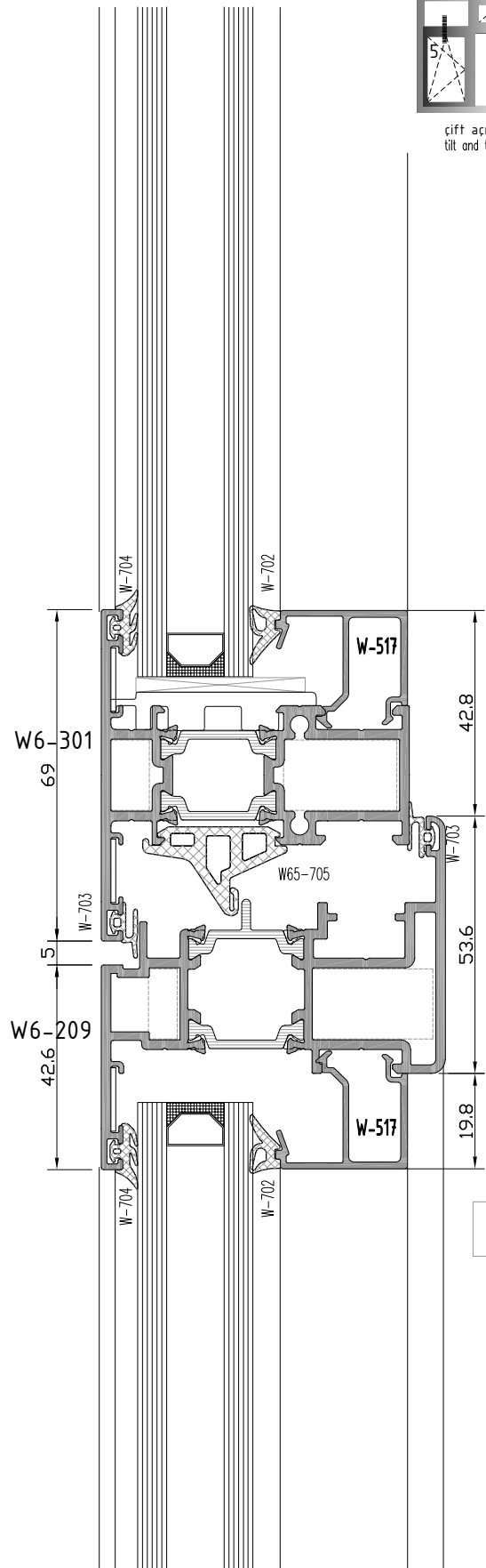

5c

W6
W 65-2T YALITIMLI SERİ
W65-2T INSULATED SERIES

ALT DETAYI
BOTTOM EDGE DETAIL

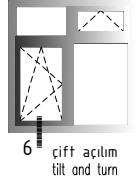

6b

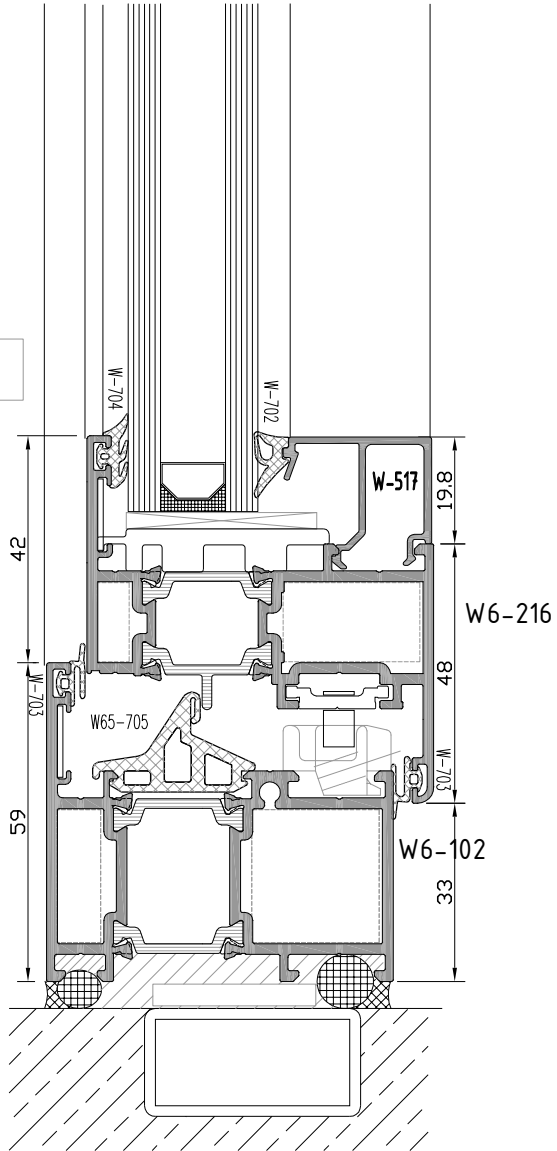

6a

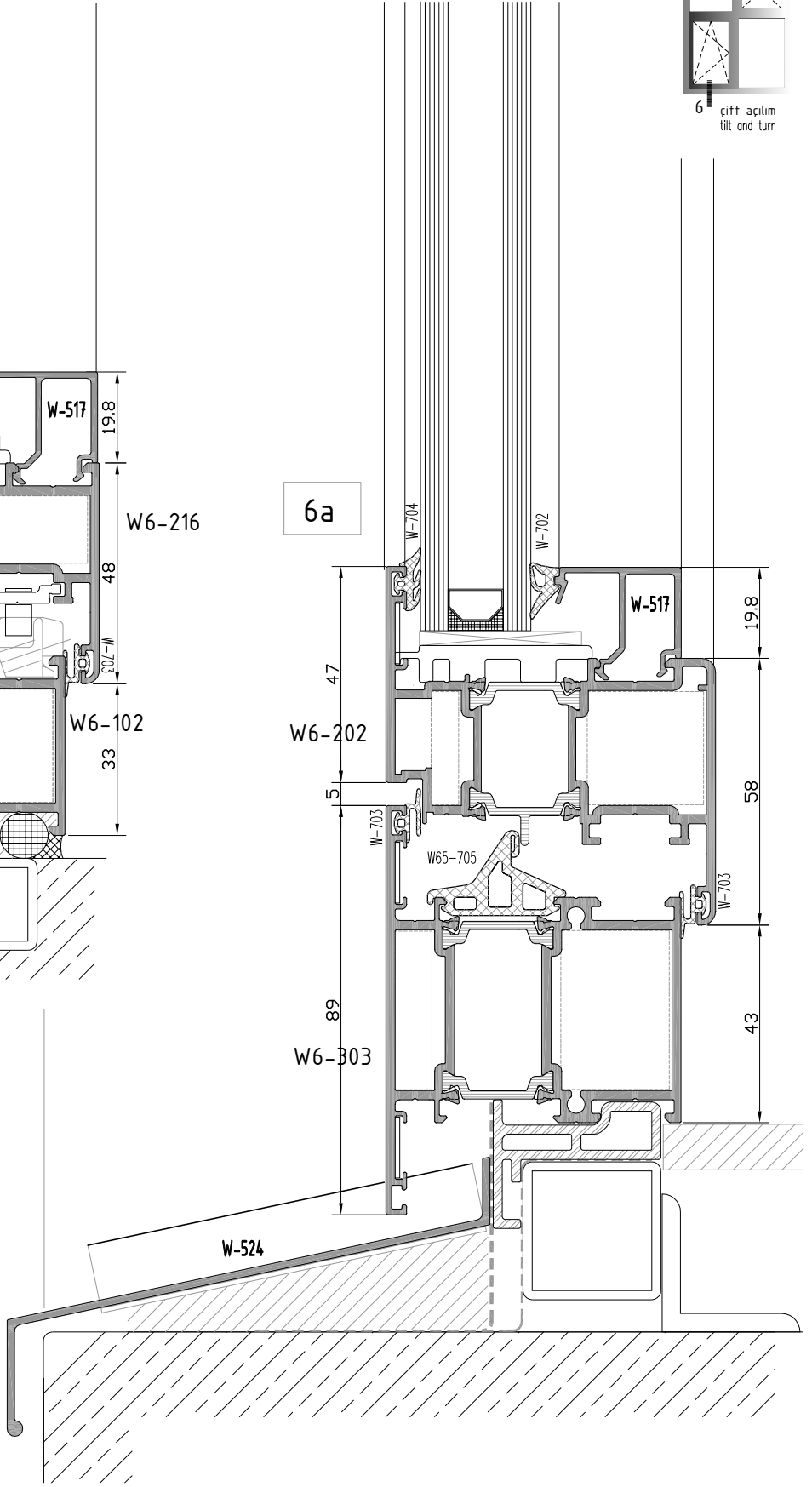

not to scale

W6
W 65-2T YALITIMLI SERİ
W65-2T INSULATED SERIES

KÖŞE DETAYI
CORNER DETAIL

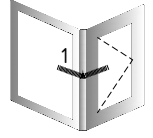

köşe dönüş
corner turn

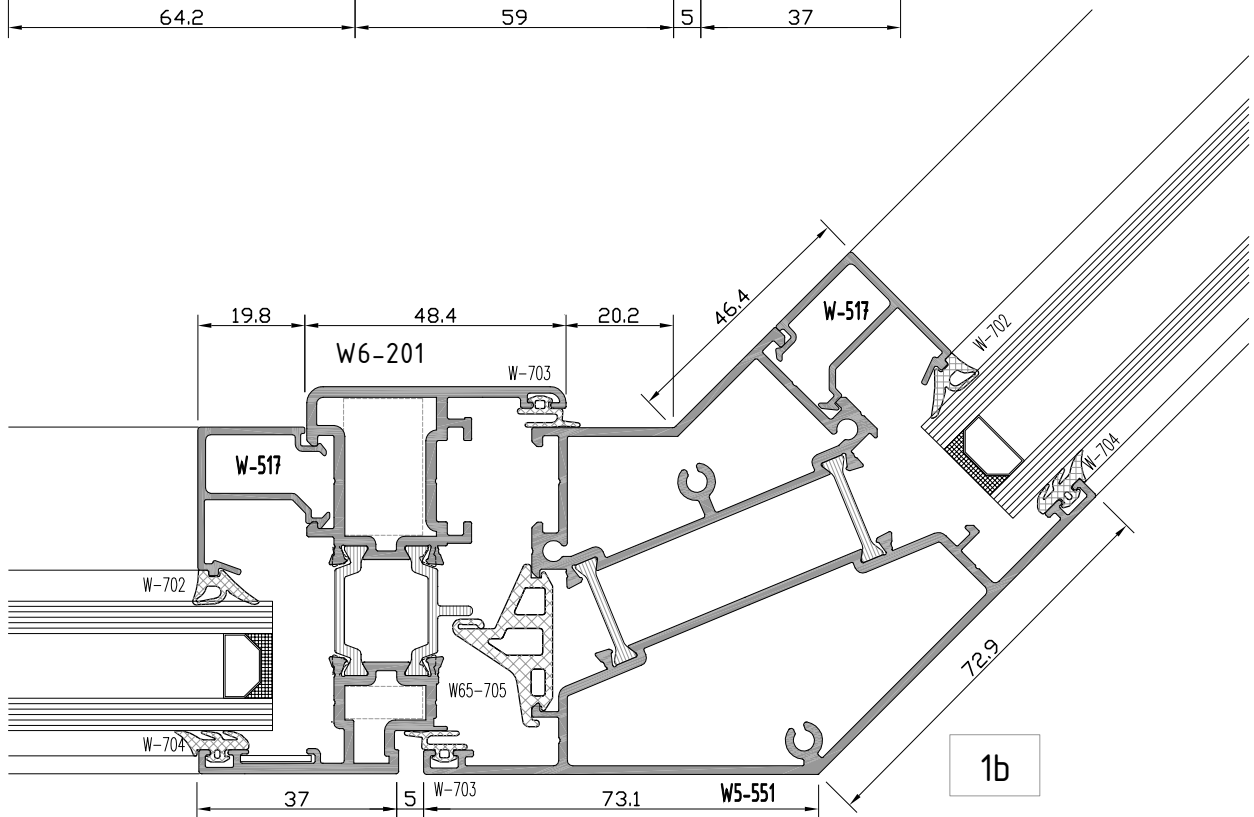
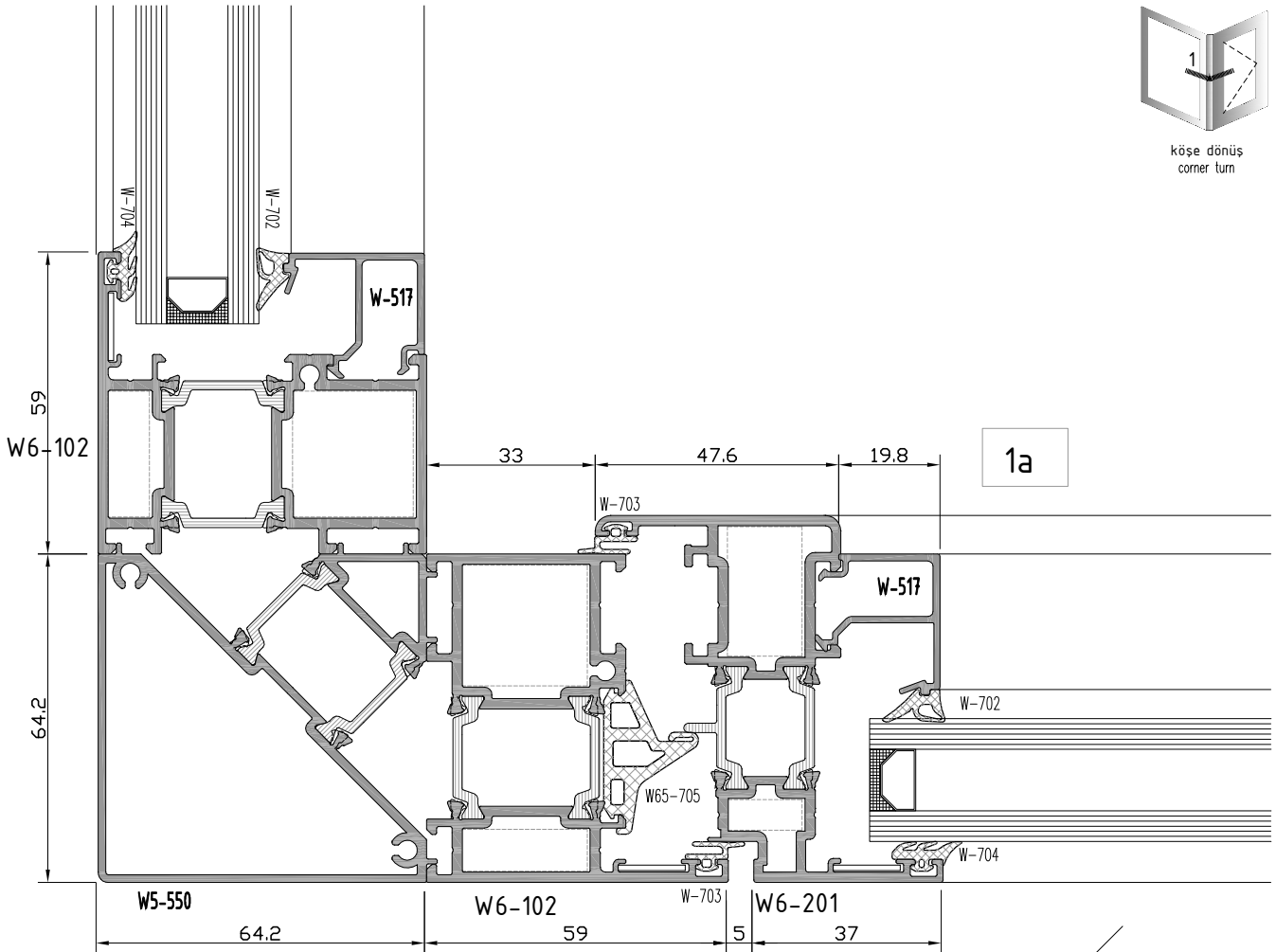

not to scale

W6
W 65-2T YALITIMLI SERİ
W65-2T INSULATED SERIES

YAN BİTİM DETAYI
WALL CONNECTION DETAIL

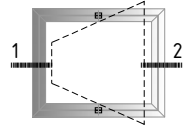

pivot açılım
pivot opening

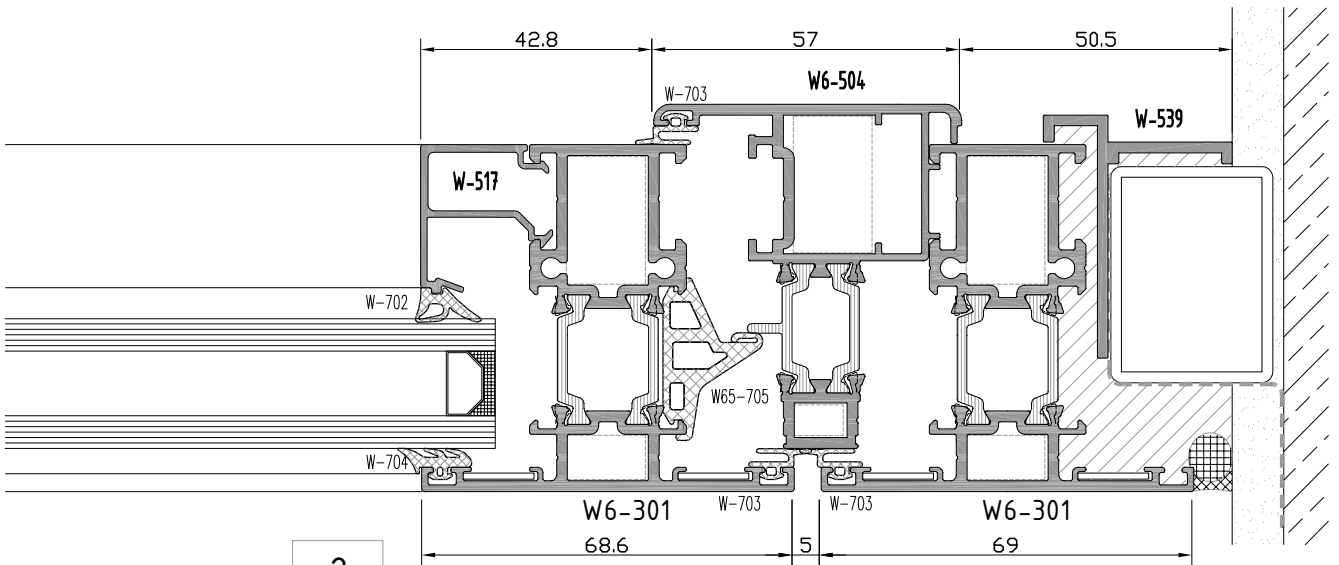
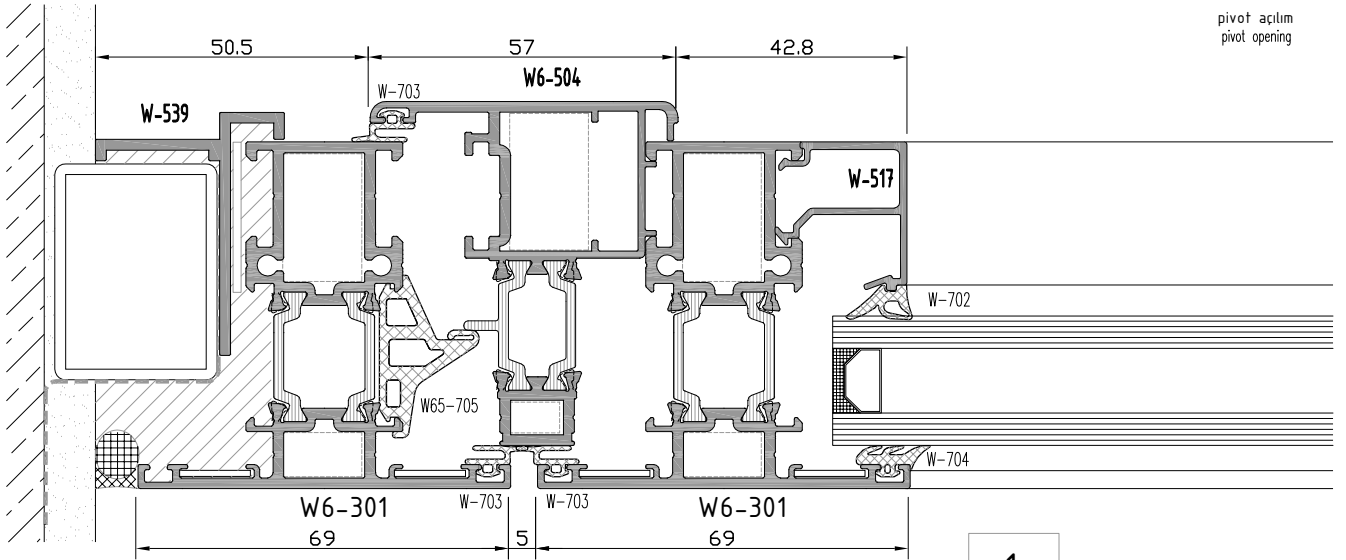

W6
W 65-2T YALITIMLI SERİ
W65-2T INSULATED SERIES

ÜST-ALT BITİM DETAYI
TOP EDGE-BOTTOM EDGE DETAIL

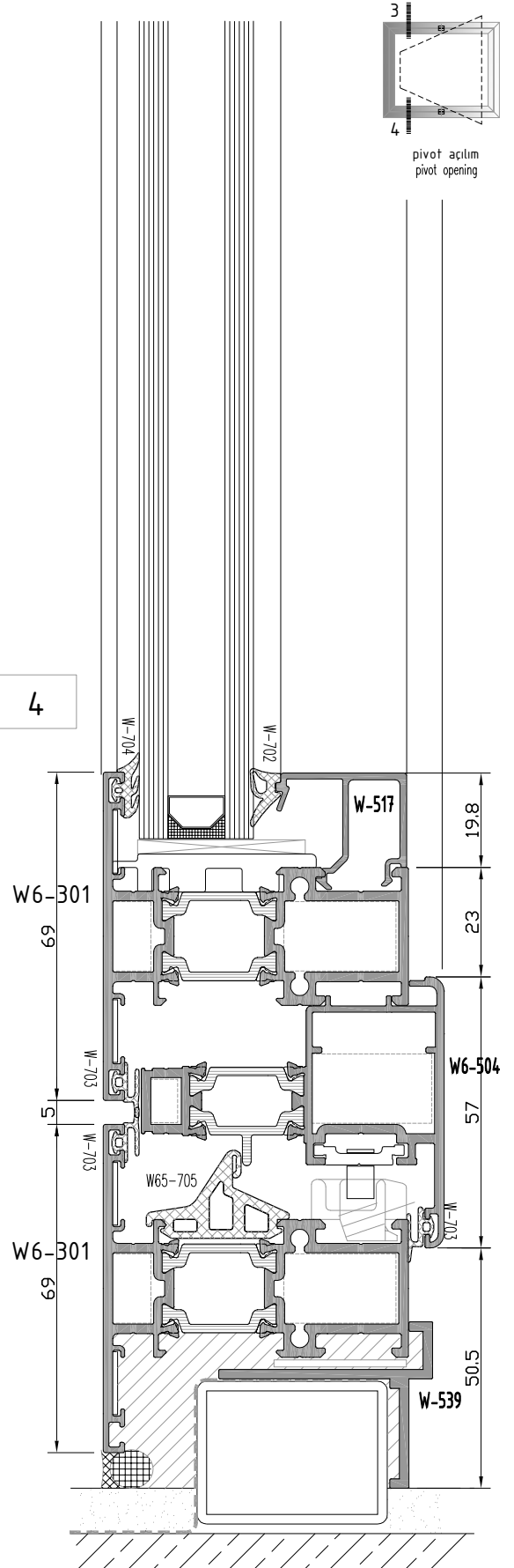
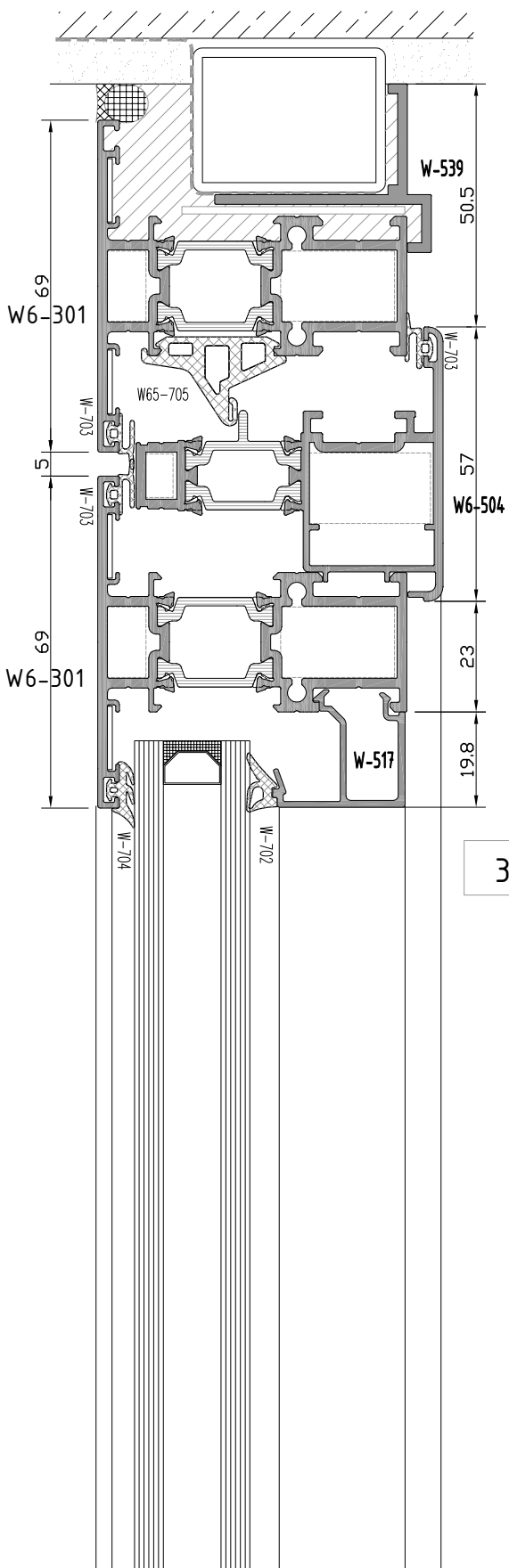

not to scale

W6
W 65-2T YALITIMLI SERİ
W65-2T INSULATED SERIES

ÜST-ALT BİTİM DETAYI
TOP EDGE-BOTTOM EDGE DETAIL

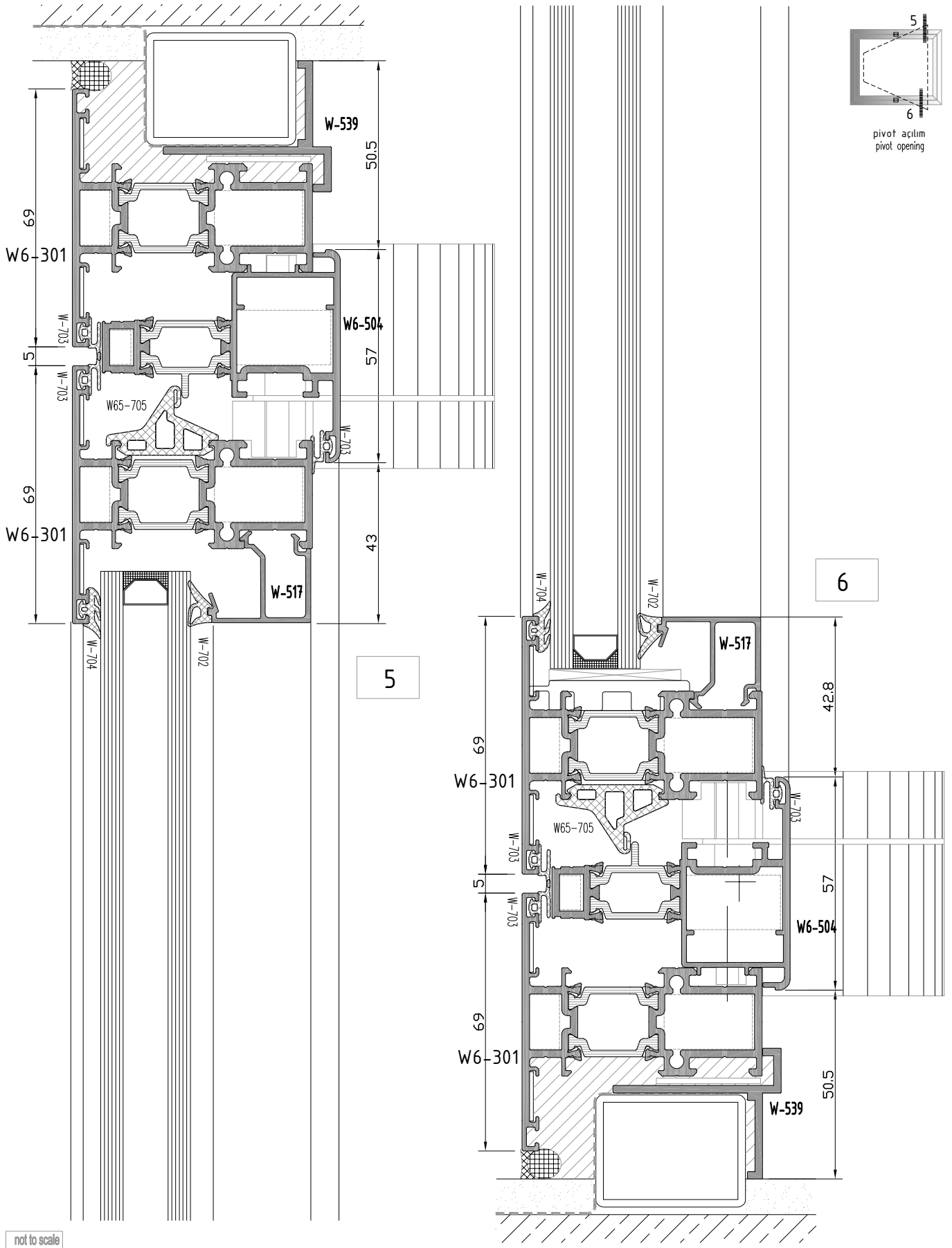

W6
W 65-2T YALITIMLI SERİ
W65-2T INSULATED SERIES

YAN BİTİM DETAYI
WALL CONNECTION DETAIL

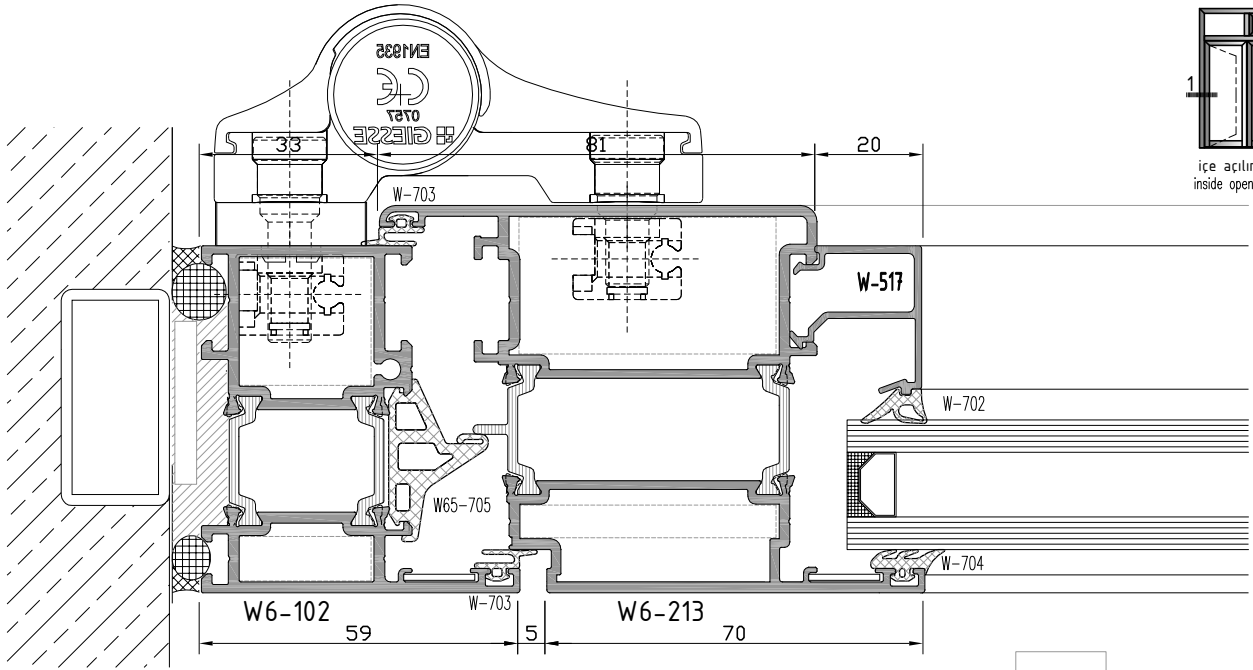

1a

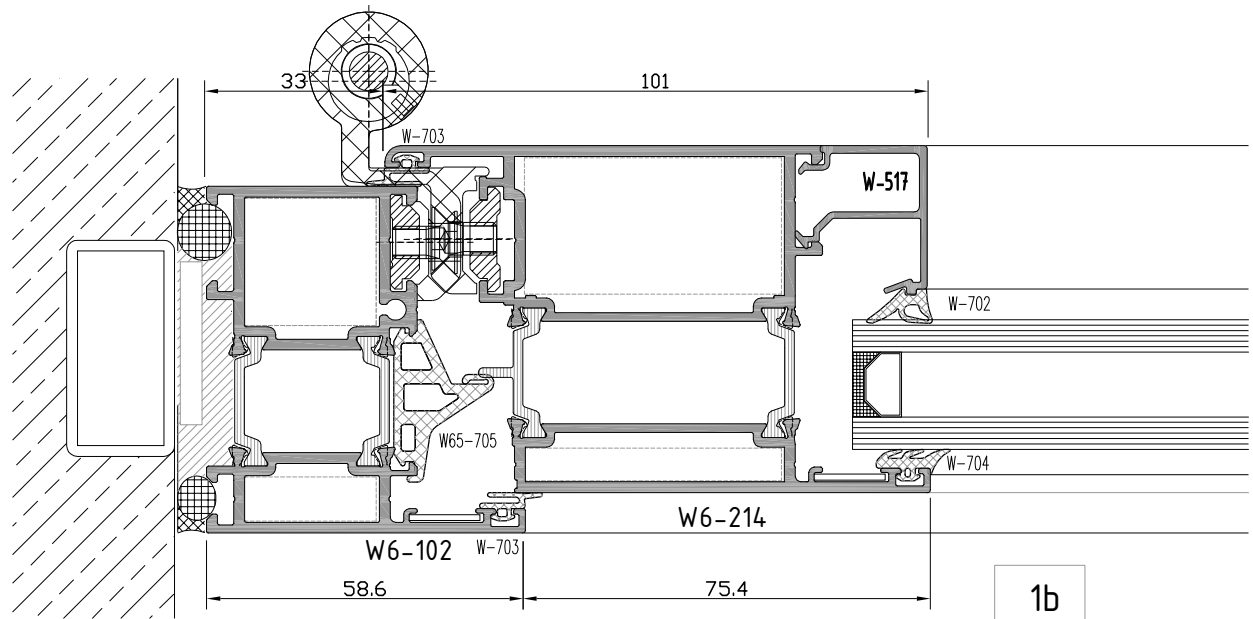

1b

W6
W 65-2T YALITIMLI SERİ
W65-2T INSULATED SERIES

KANAT BİRLEŞİM DETAYI
CASEMENT JOINING DETAIL

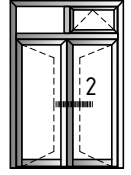

içe açılım kapı
inside opening door

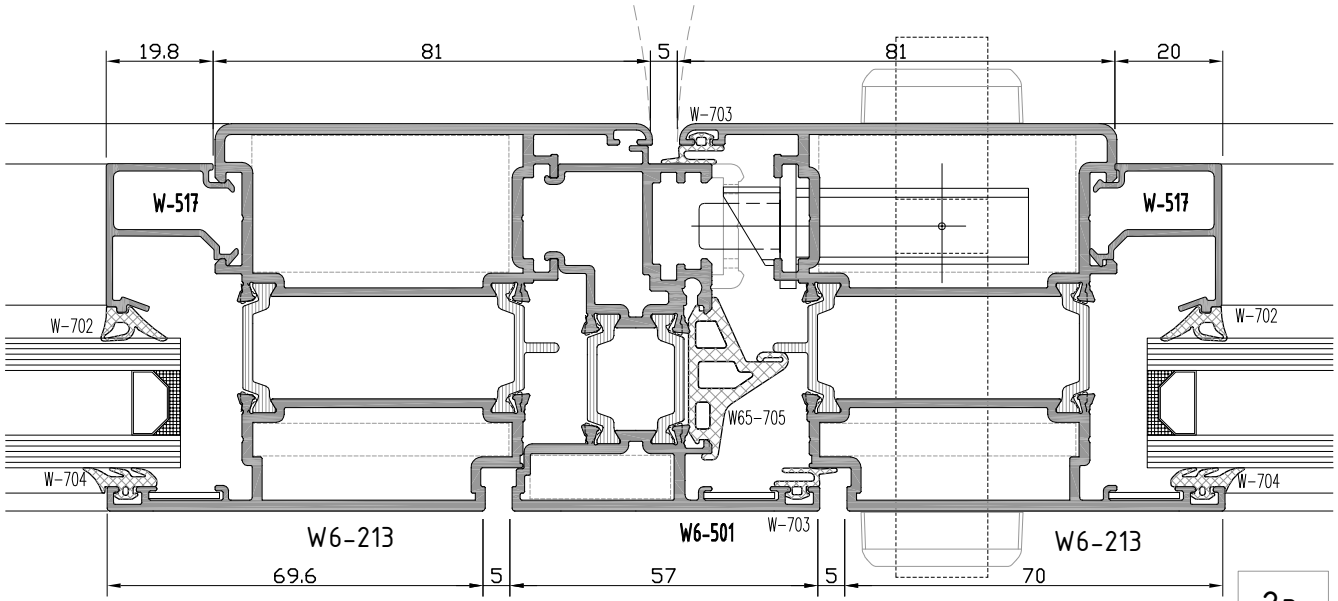

2a

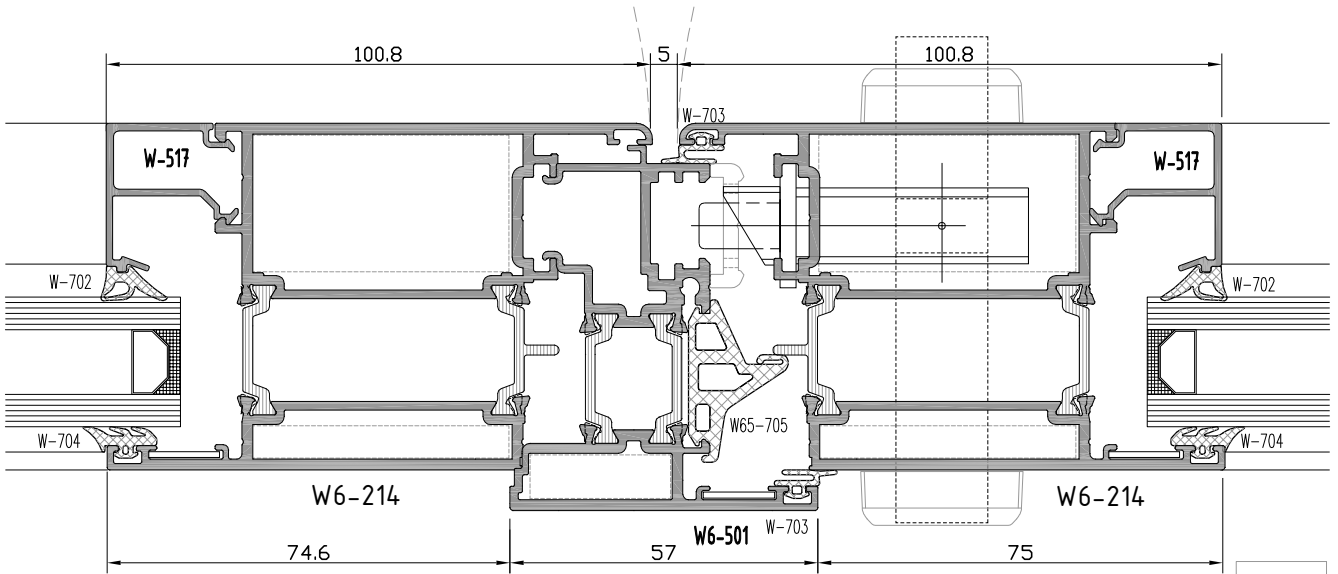

2b

W6
W 65-2T YALITIMLI SERİ
W65-2T INSULATED SERIES

ÜST BİTİM-ORTA KAYIT DETAYI
TOP EDGE-MULLION DETAIL

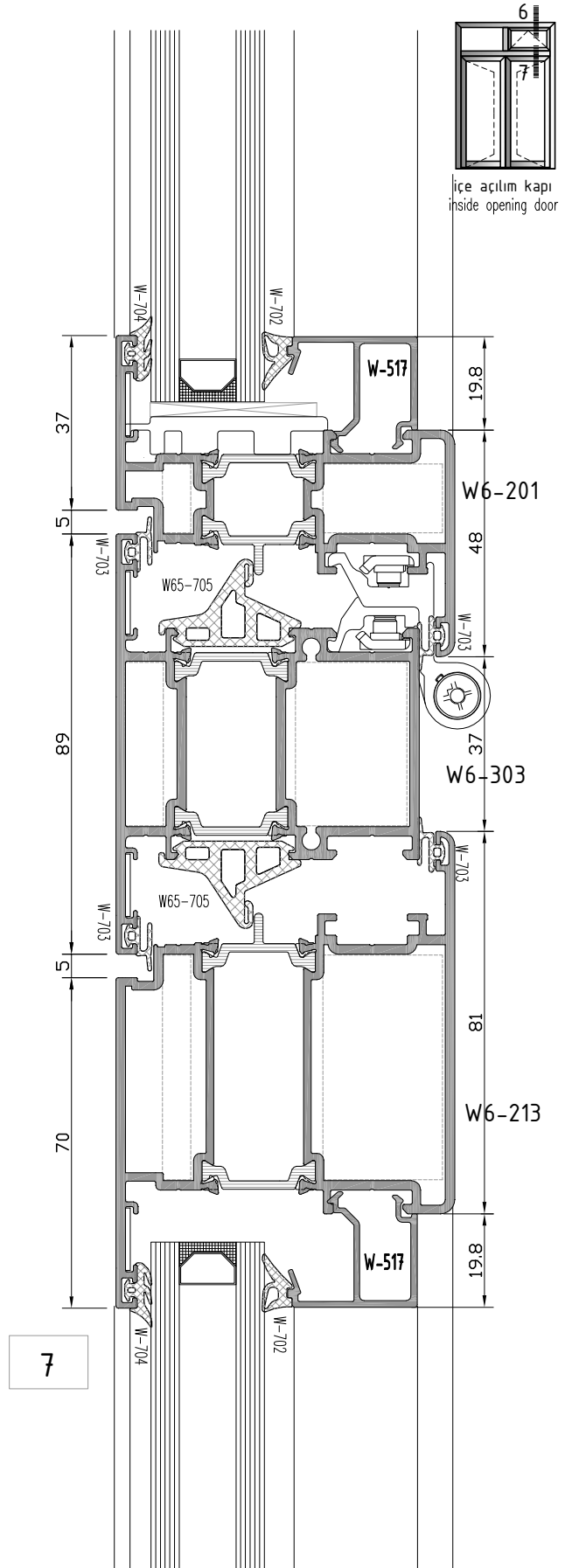
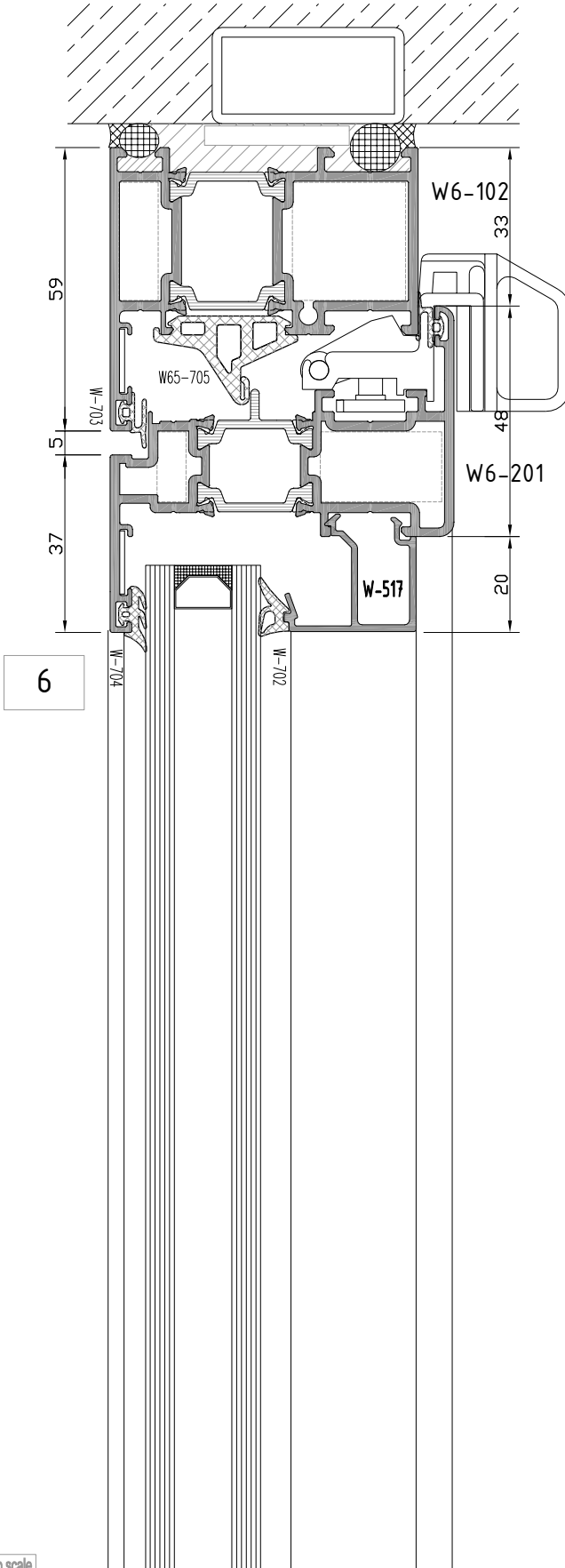

W6
W 65-2T YALITIMLI SERİ
W65-2T INSULATED SERIES

ALT BİTİM DETAYI
BOTTOM EDGE DETAIL

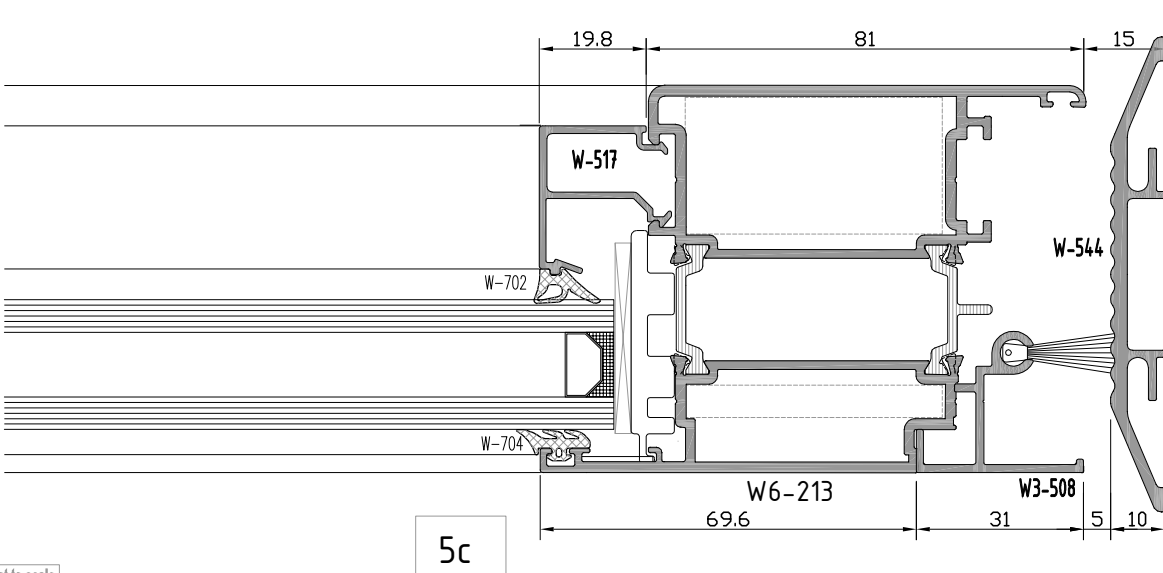
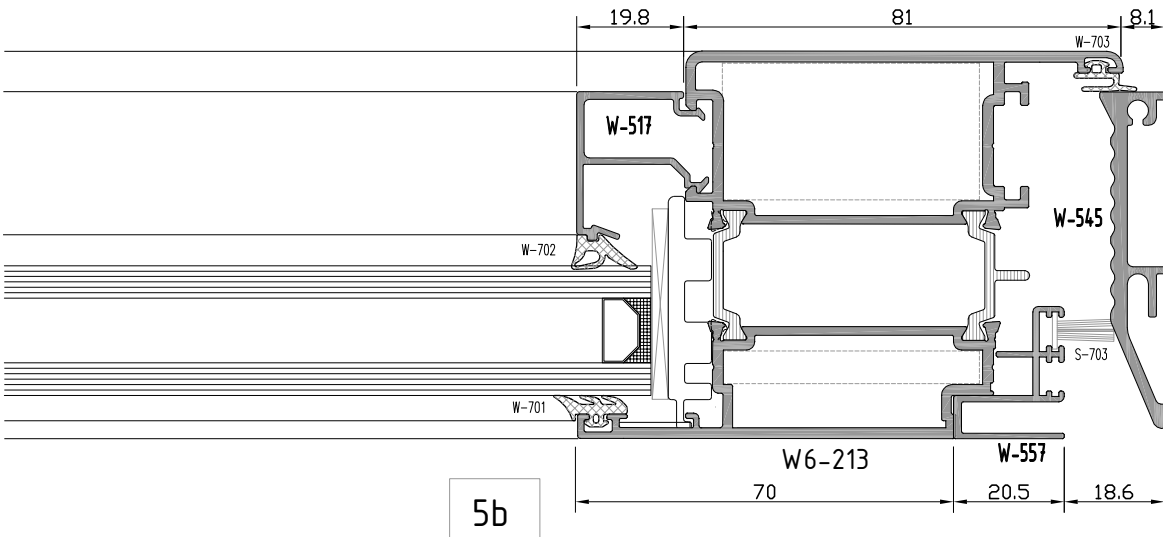
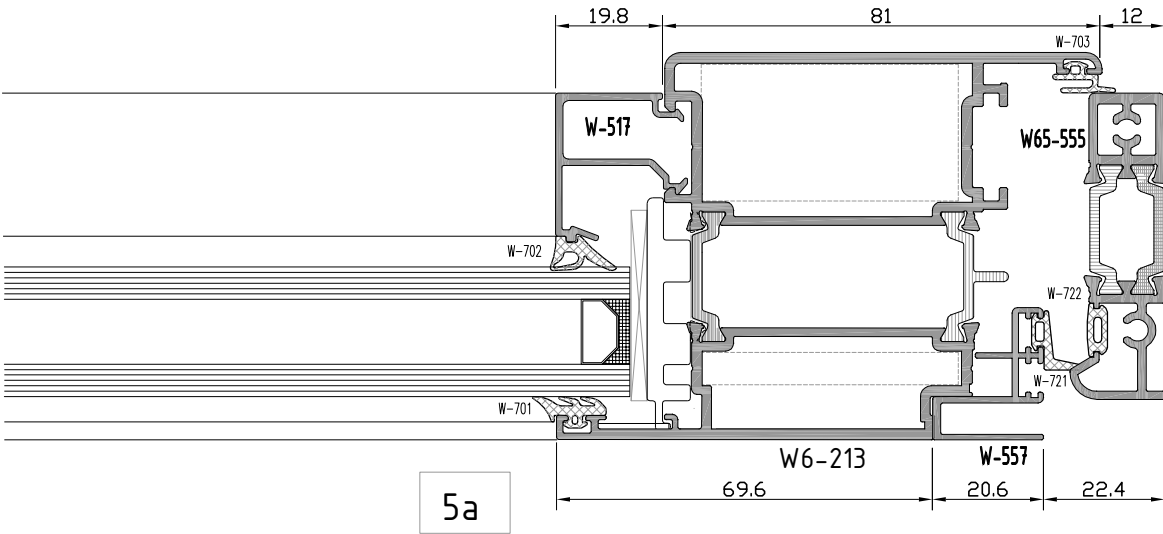

not to scale

W6
W 65-2T YALITIMLI SERİ
W65-2T INSULATED SERIES

ALT BİTİM DETAYI
BOTTOM EDGE DETAIL

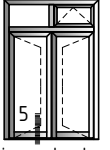

5
içe açılım kapı
inside opening door

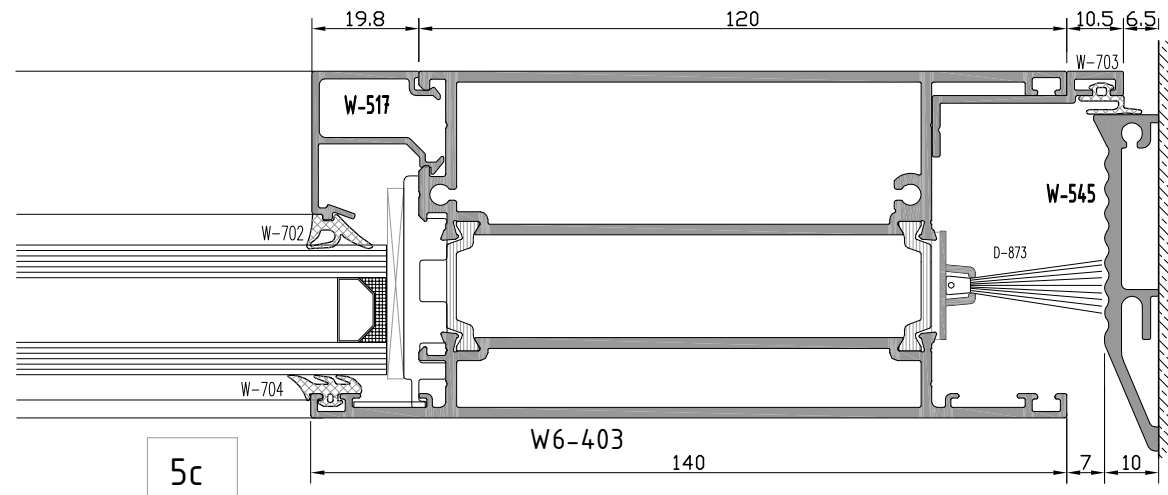
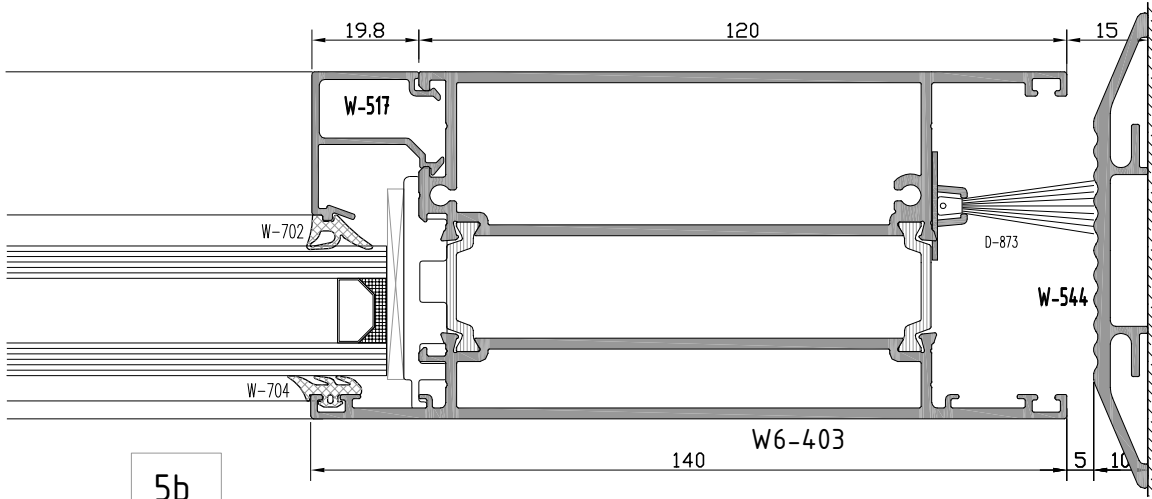
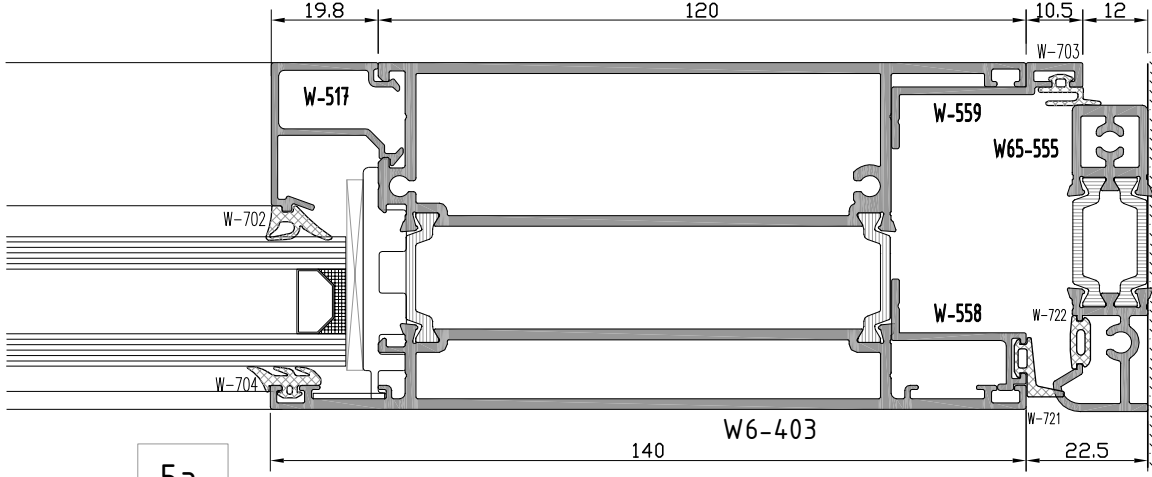
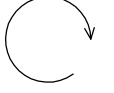

not to scale

W6
W 65-2T YALITIMLI SERİ
W65-2T INSULATED SERIES

YAN BİTİM - DETAYI
WALL CONNECTION DETAIL

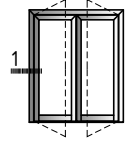

dışa açılım kapı
outside opening door

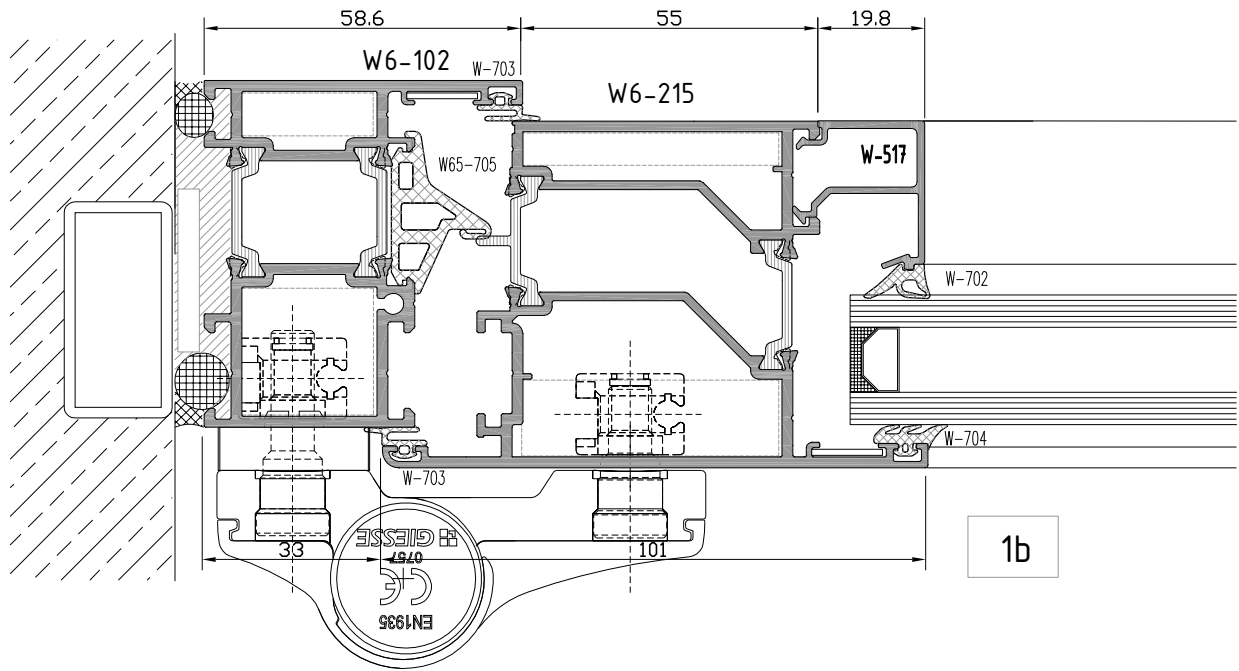
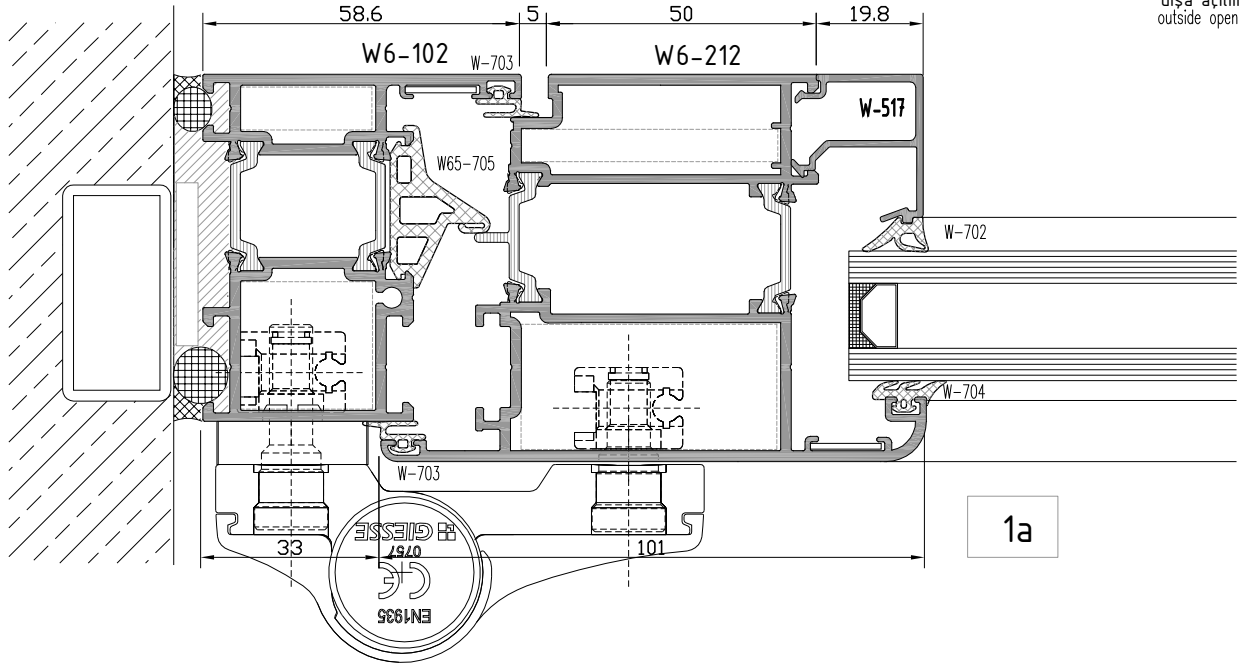

not to scale

W6
W 65-2T YALITIMLI SERİ
W65-2T INSULATED SERIES

YAN BİTİM - DETAYI
WALL CONNECTION DETAIL

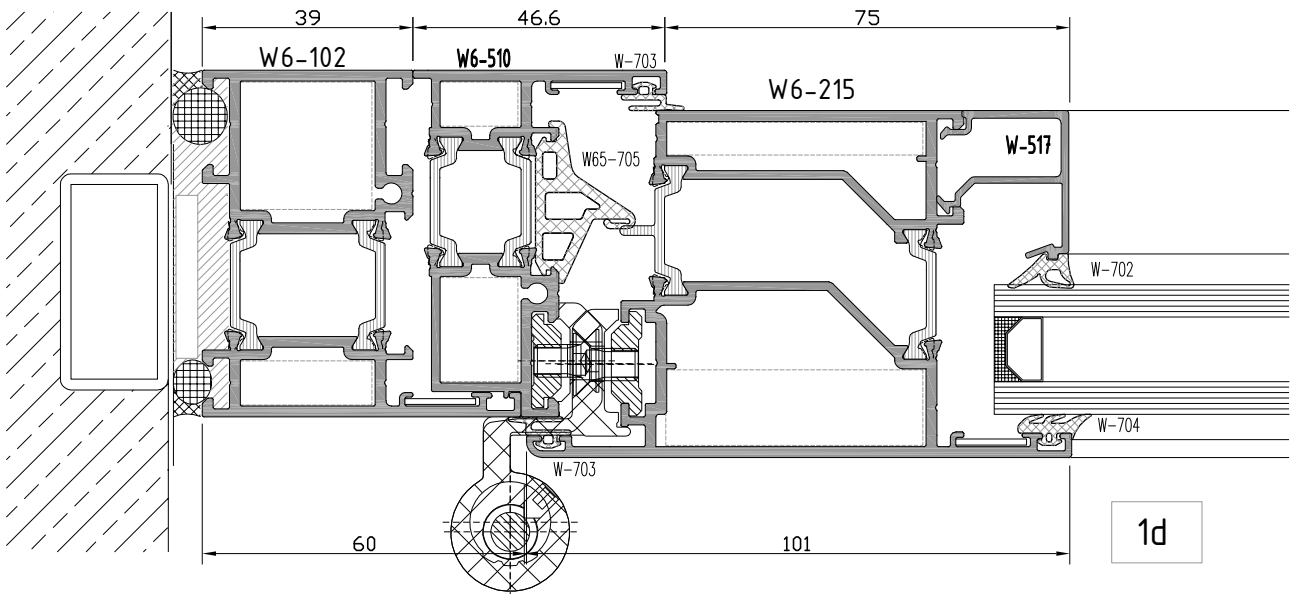
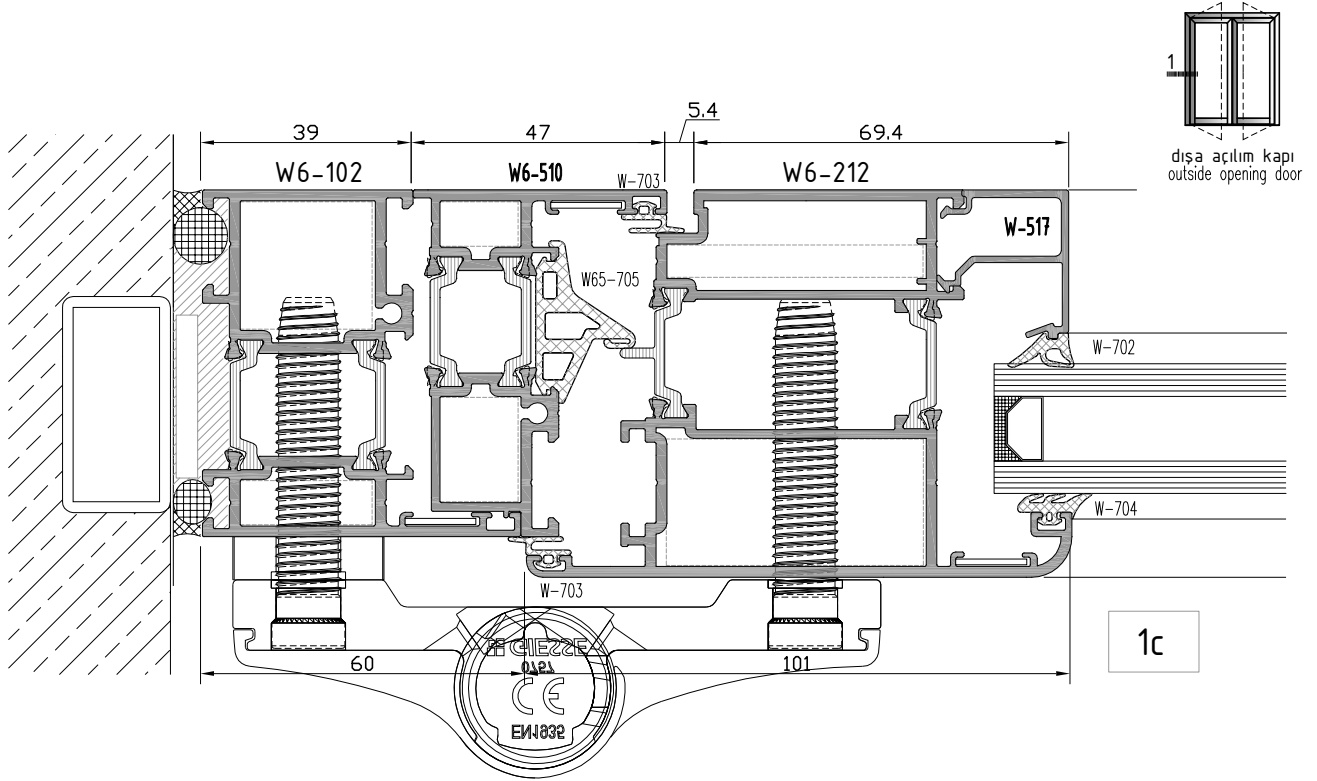

W6
W 65-2T YALITIMLI SERİ
W65-2T INSULATED SERIES

KANAT BİRLEŞİM DETAYI
CASEMENT JOINING DETAIL

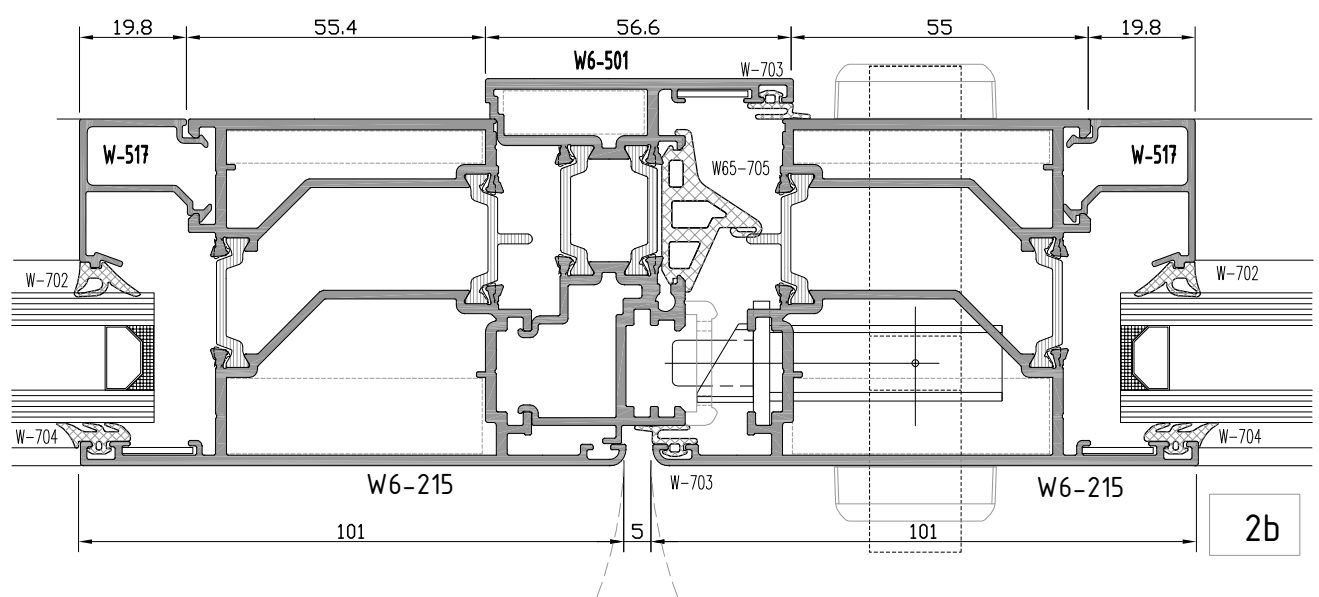
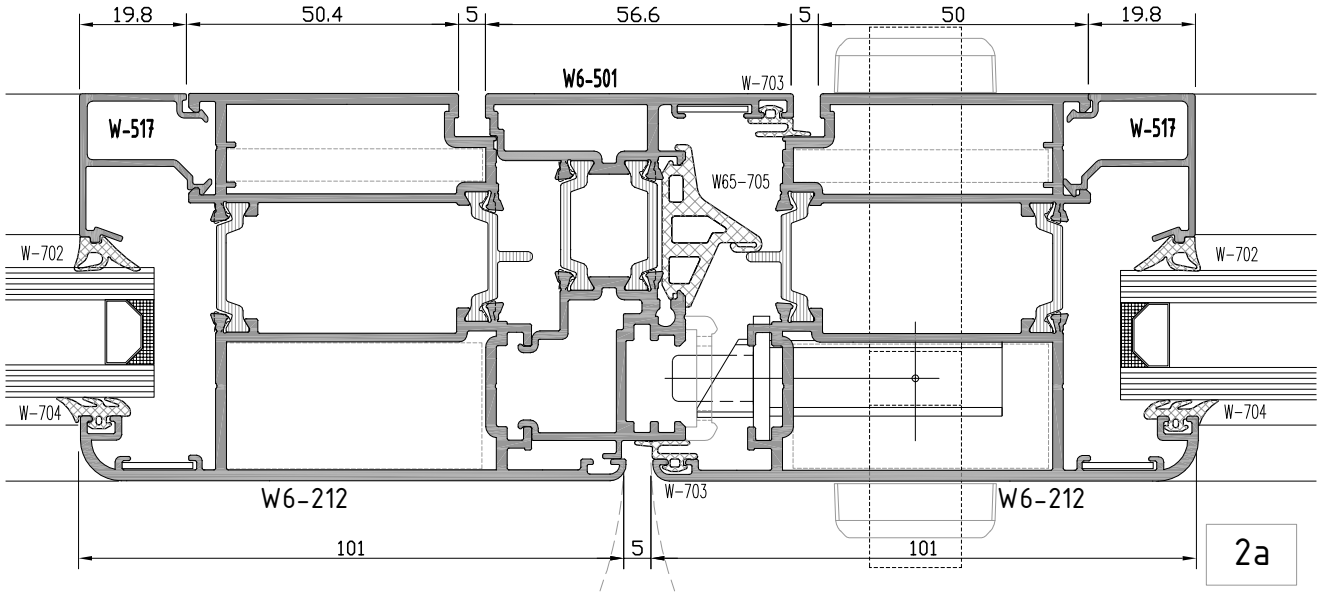
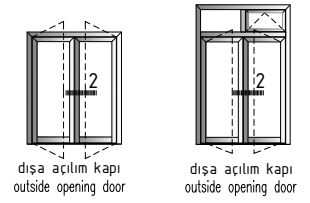

not to scale

W6
W 65-2T YALITIMLI SERİ
W65-2T INSULATED SERIES

ÜST BİTİM DETAYI
TOP EDGE - DETAIL

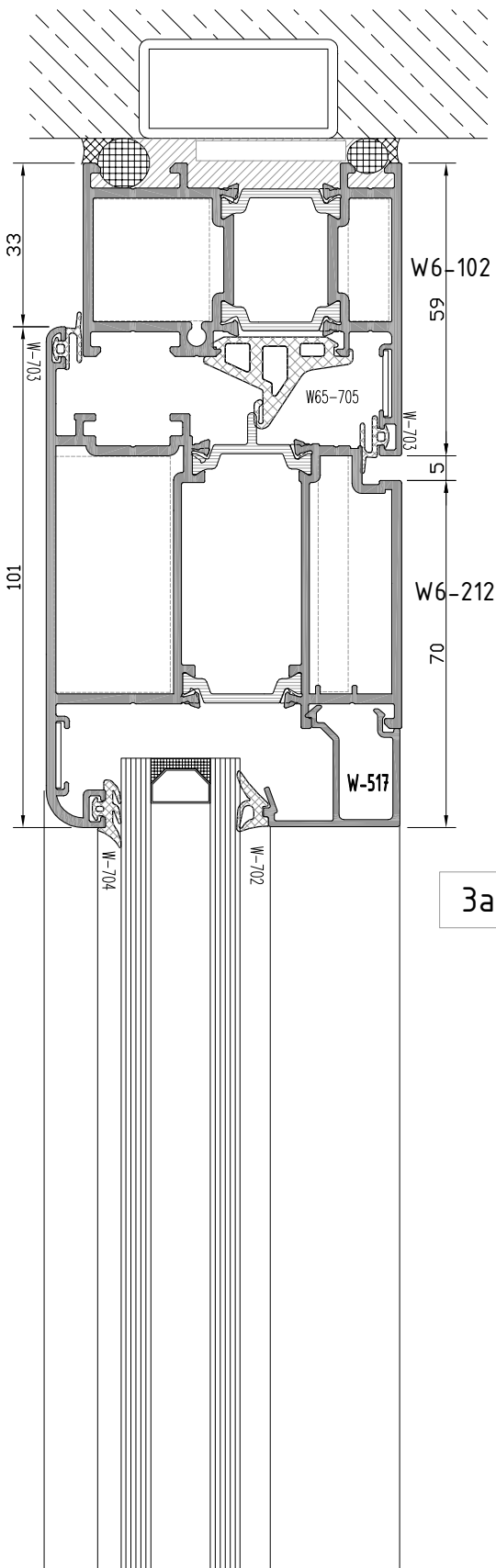

3a

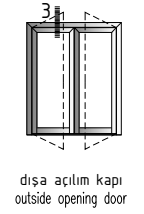
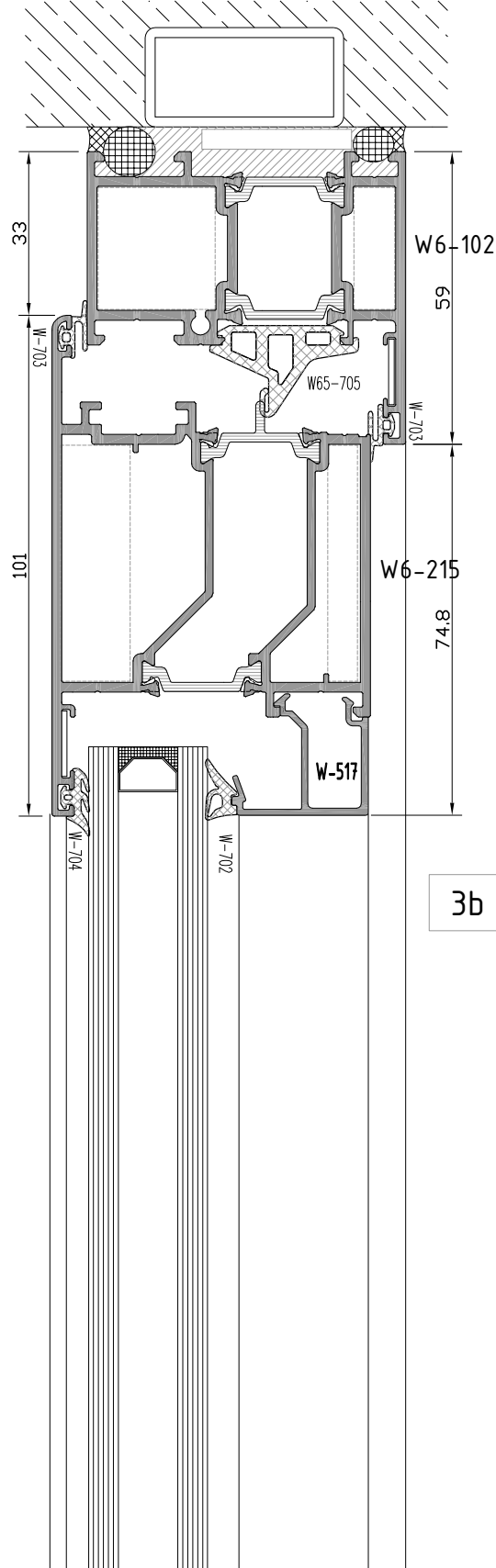

3b

W6
W 65-2T YALITIMLI SERİ
W65-2T INSULATED SERIES

ÜST BİTİM-ORTA KAYIT DETAYI
TOP EDGE-MULLION DETAIL

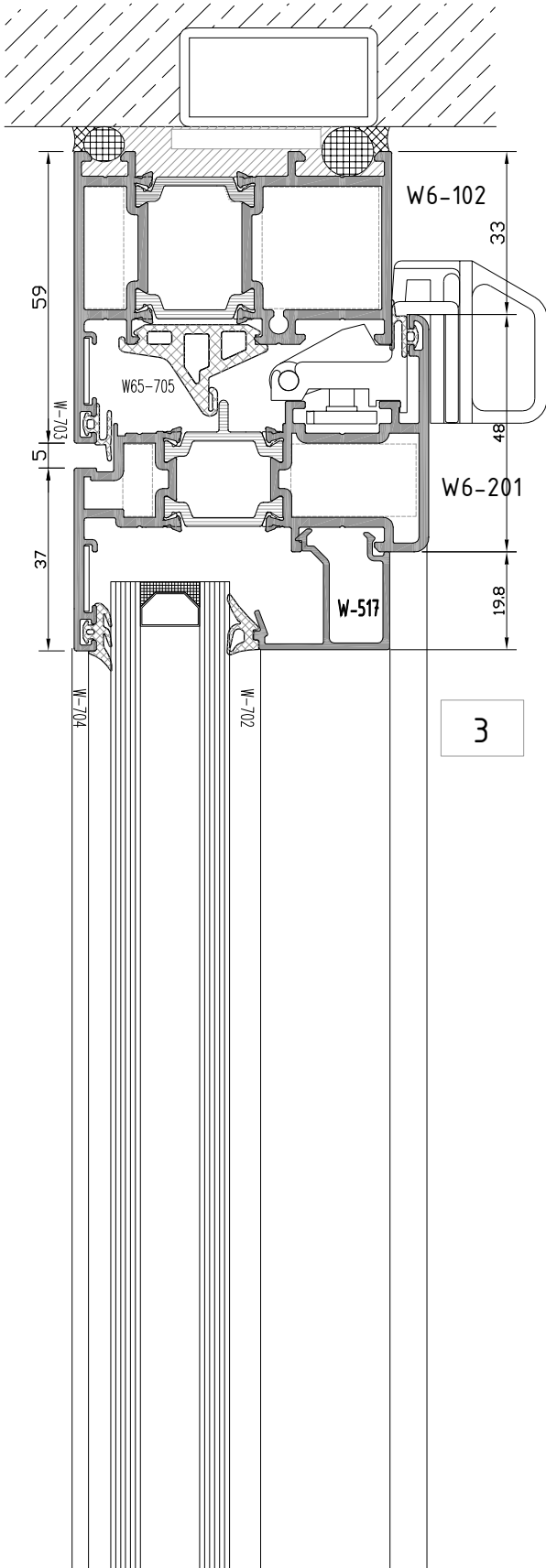

3

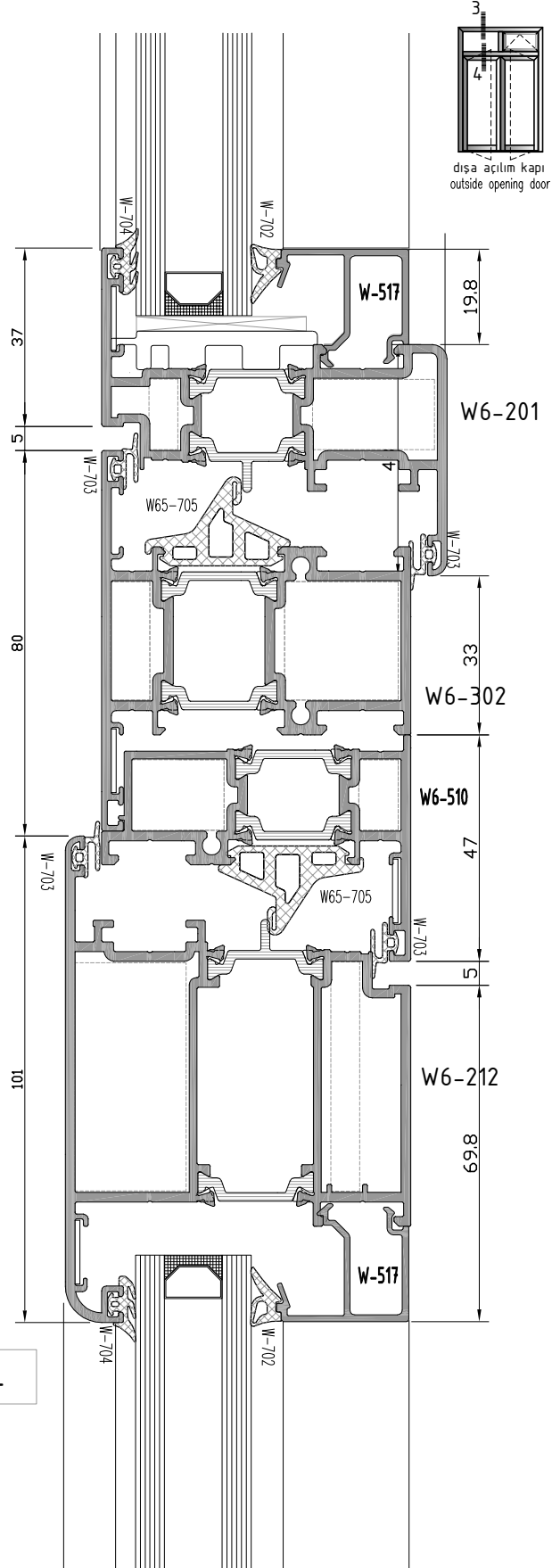

4

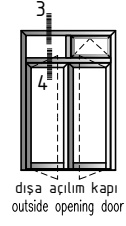

W6
W 65-2T YALITIMLI SERİ
 W65-2T INSULATED SERIES

ALT BİTİM DETAYI
 BOTTOM EDGE DETAIL

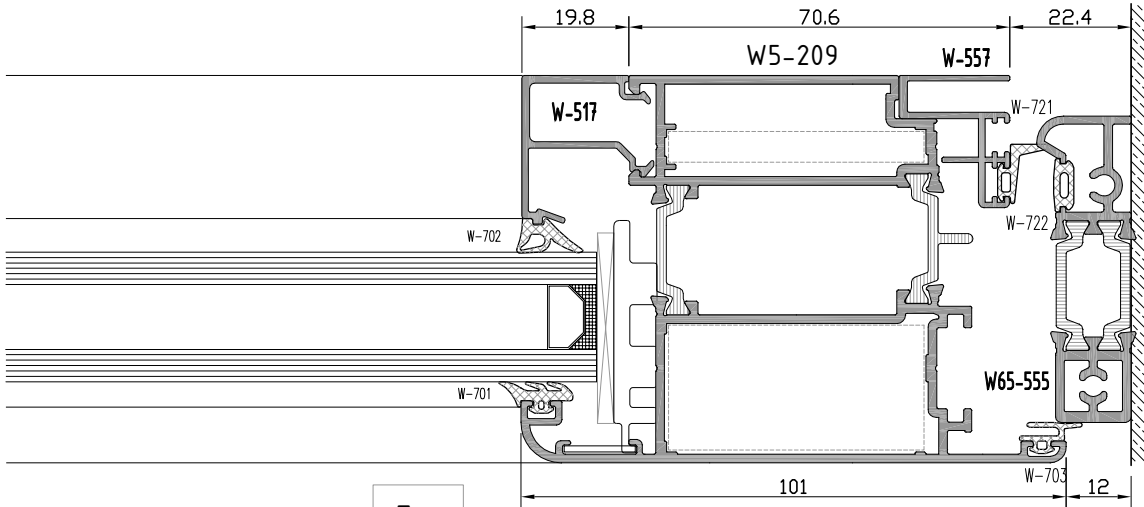

5a

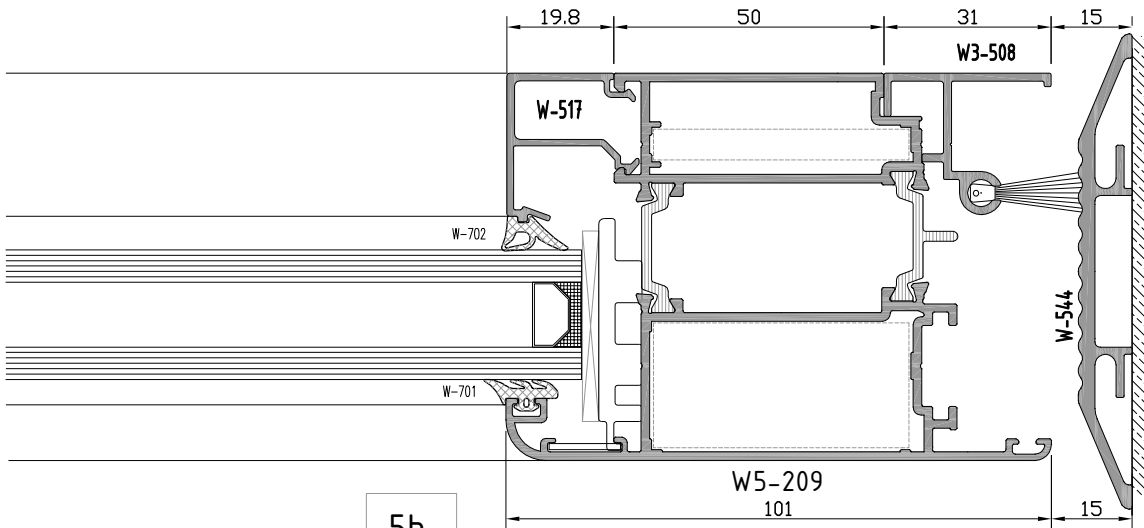
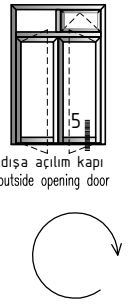

5b

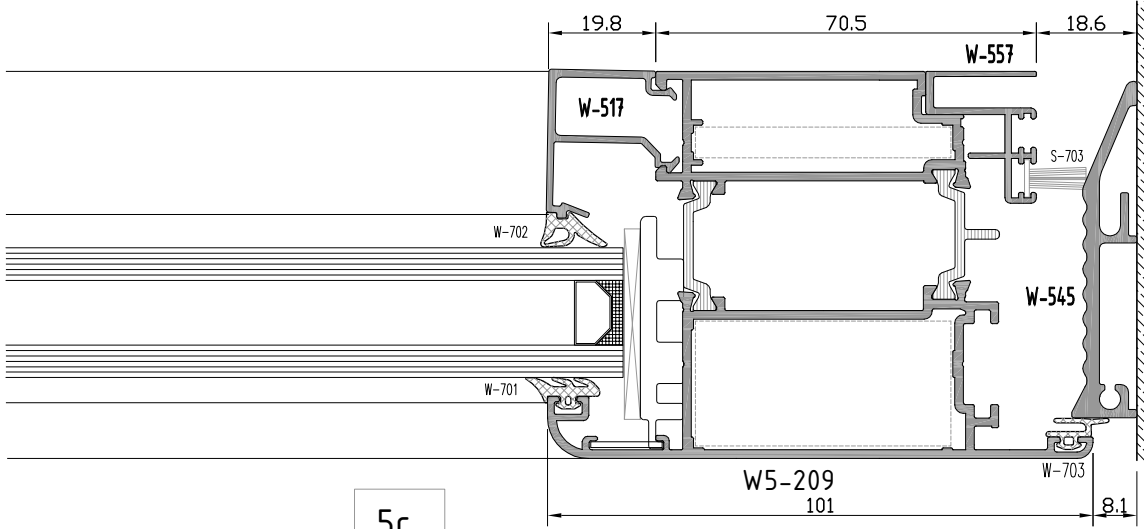

5c

not to scale

W6
W 65-2T YALITIMLI SERİ
W65-2T INSULATED SERIES

ALT BİTİM DETAYI
BOTTOM EDGE DETAIL

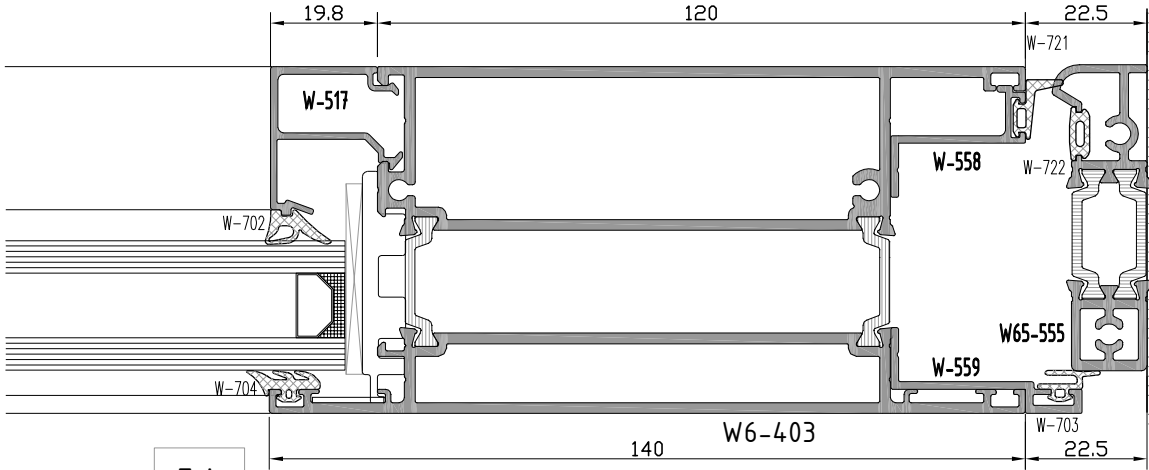

5d

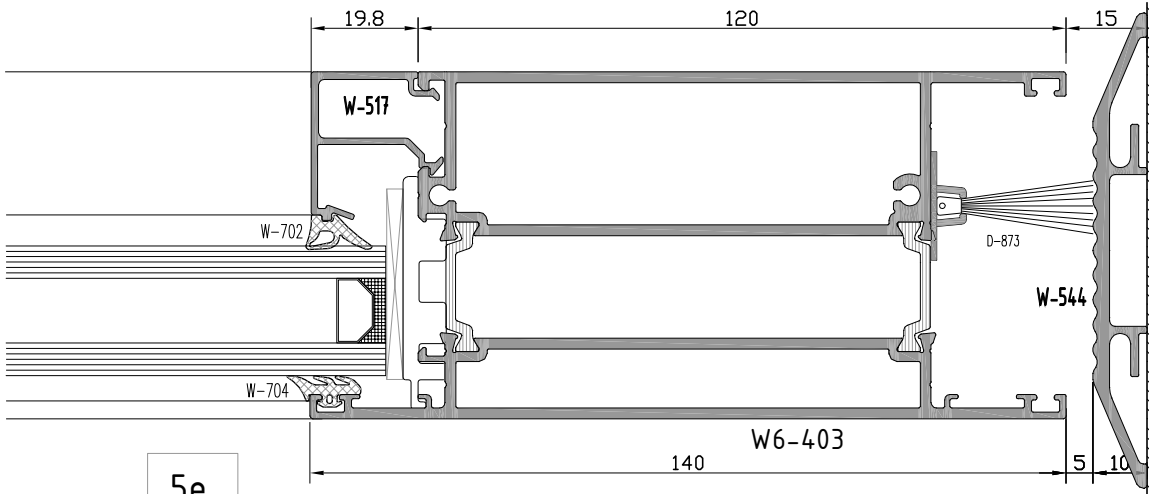

5e

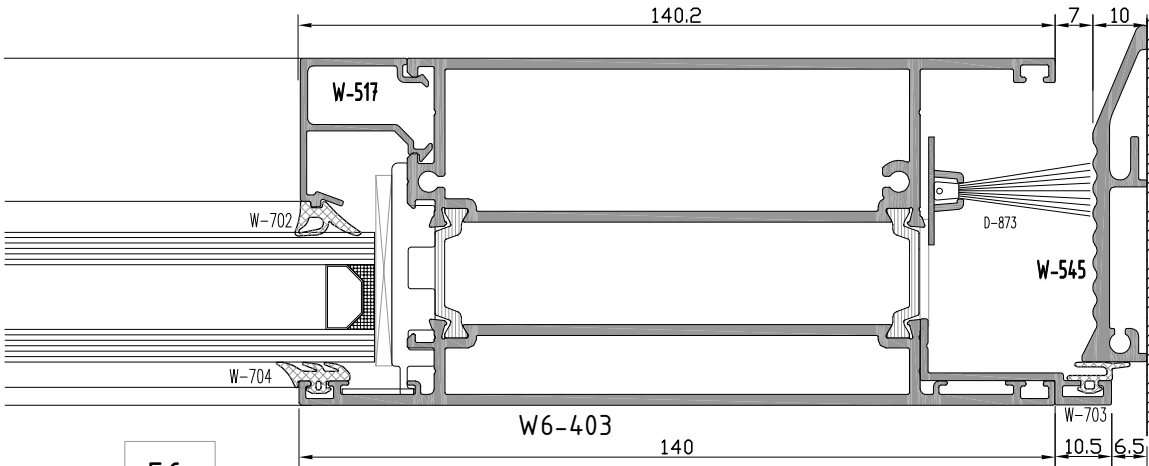

5f

W6
W 65-2T YALITIMLI SERİ
W65-2T INSULATED SERIES

YAN BİTİM-ORTA KAYIT DETAYI
WALL CONNECTION-MULLION DETAIL

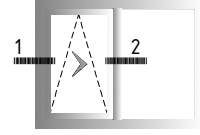

wosrogen sürme açılım
wosrogen sliding opening

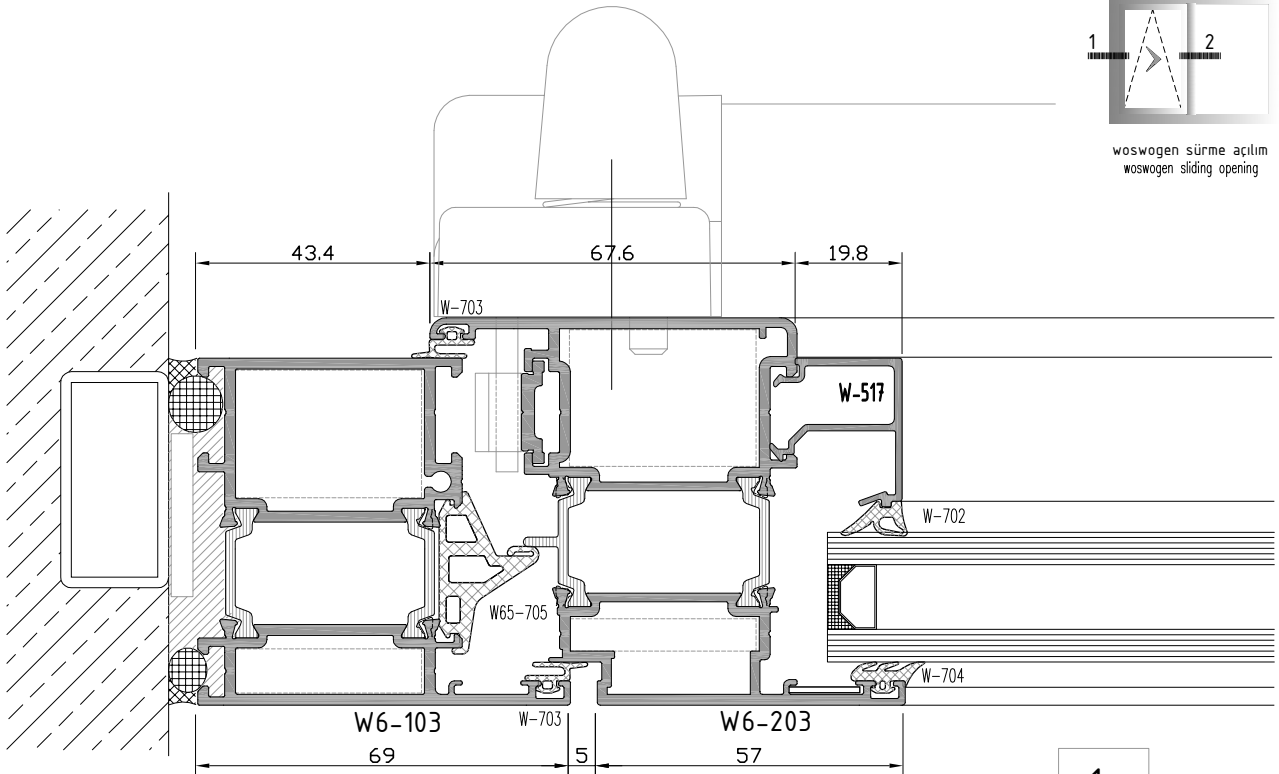

1

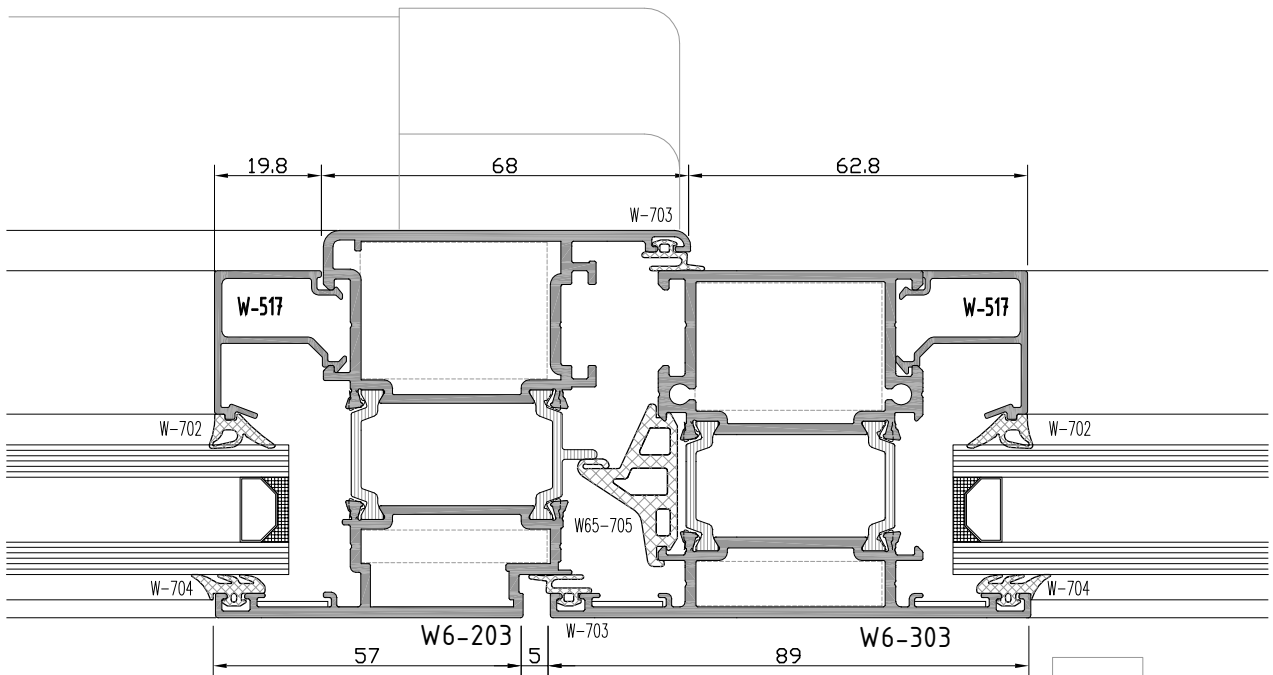

2

not to scale

W6
W 65-2T YALITIMLI SERİ
W65-2T INSULATED SERIES

ÜST - ALT BİTİM DETAYI
TOP - BOTTOM EDGE DETAIL

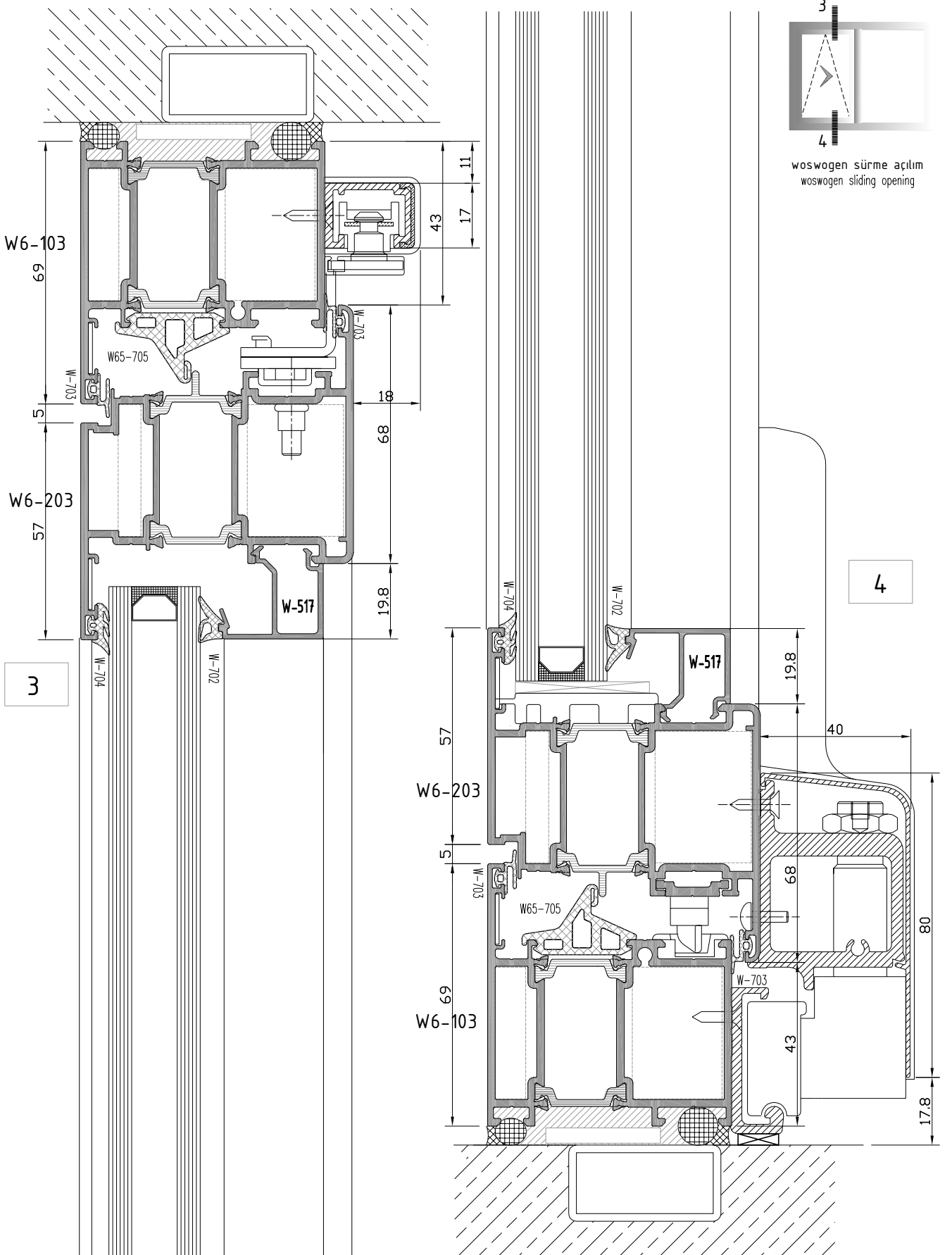

W6
W 65-2T YALITIMLI SERİ
W65-2T INSULATED SERIES

YAN BİTİM-ORTA KAYIT DETAYI
WALL CONNECTION-MULLION DETAIL

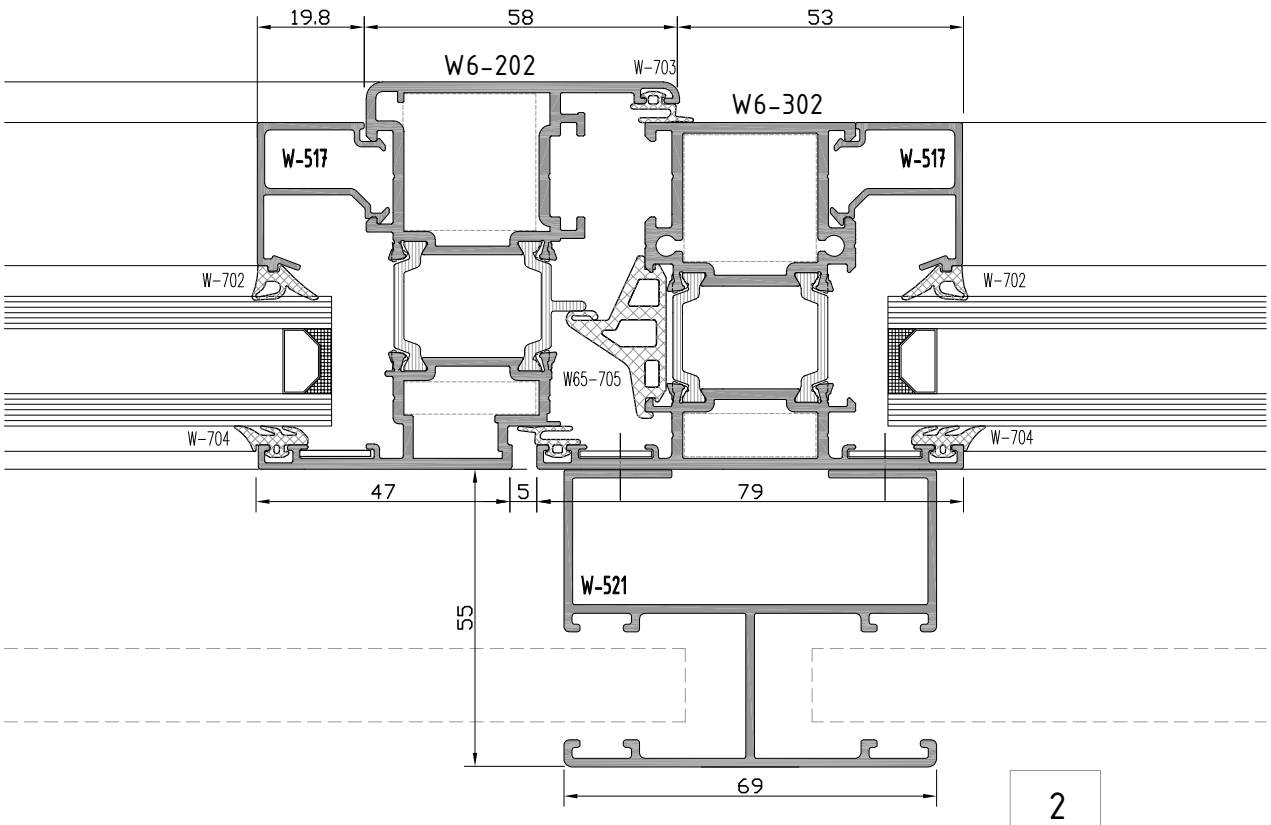
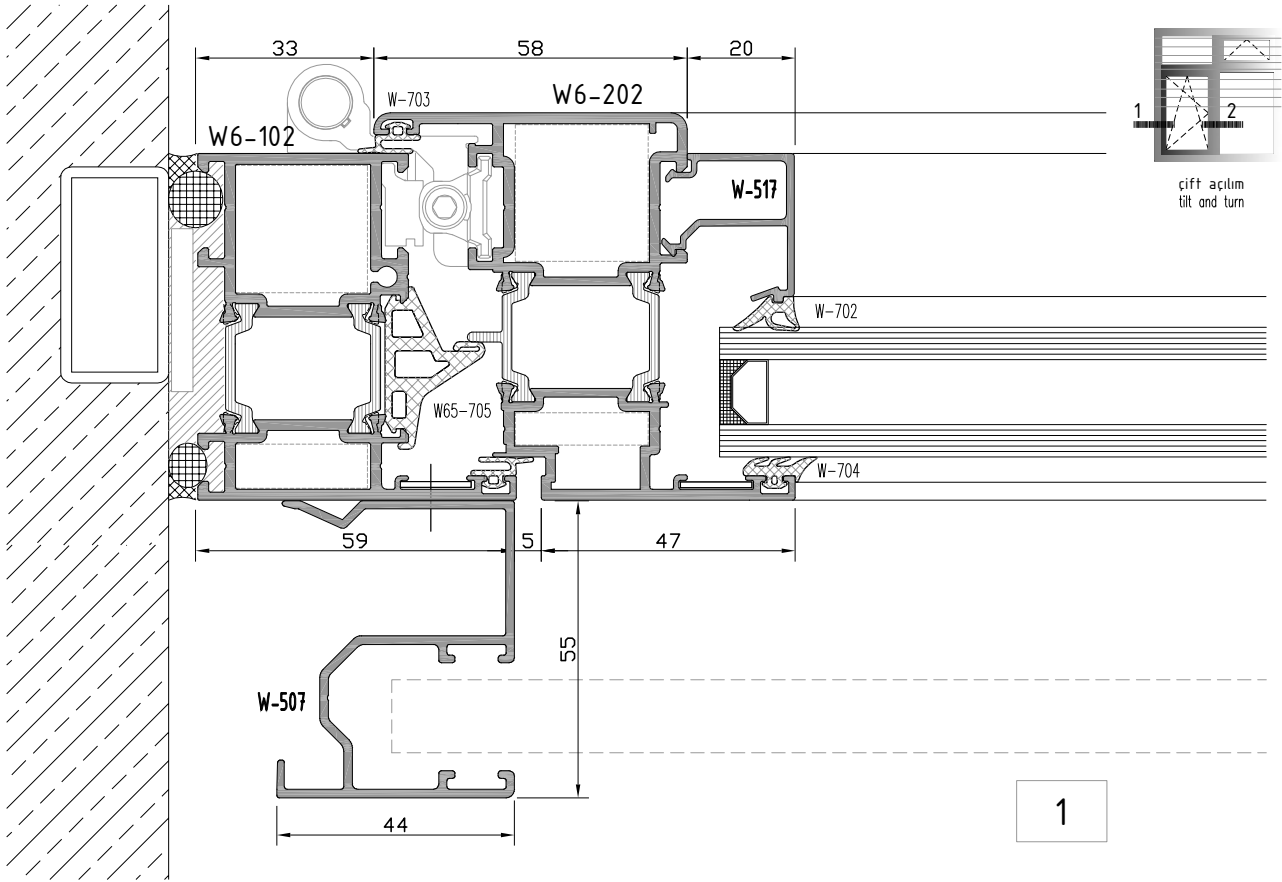

not to scale

W6
W 65-2T YALITIMLI SERİ
W65-2T INSULATED SERIES

ÜST BITİM DETAYI
TOP EDGE DETAIL

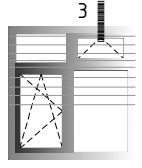

çift açılım
tit and turn

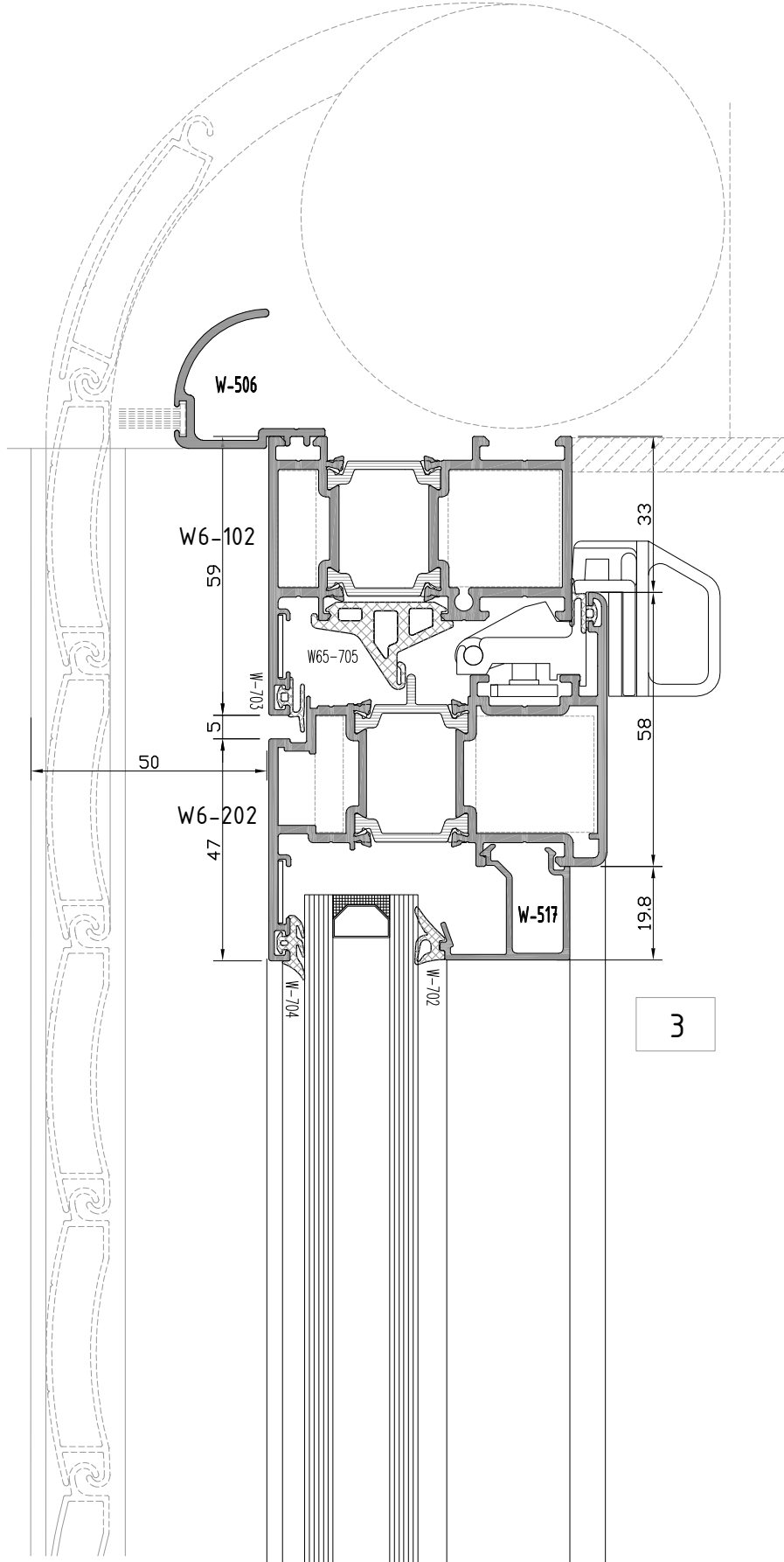

not to scale

W6
W 65-2T YALITIMLI SERİ
W65-2T INSULATED SERIES

YAN BİTİM DETAYI
WALL CONNECTION DETAIL

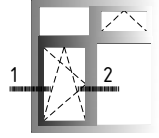

saklı kanat pencere
invisible casement window

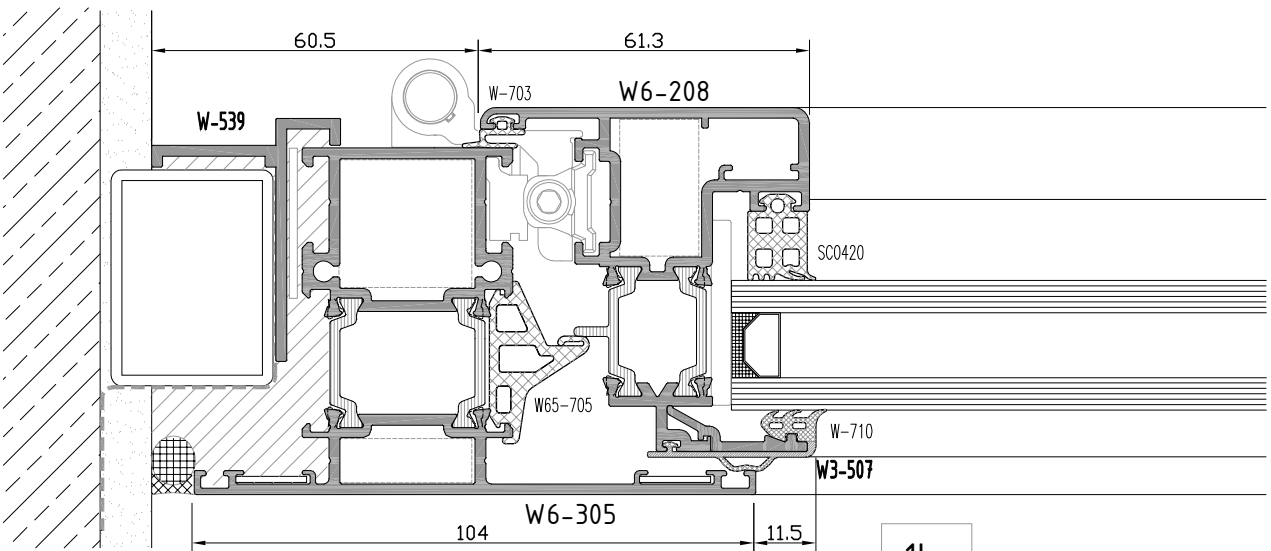
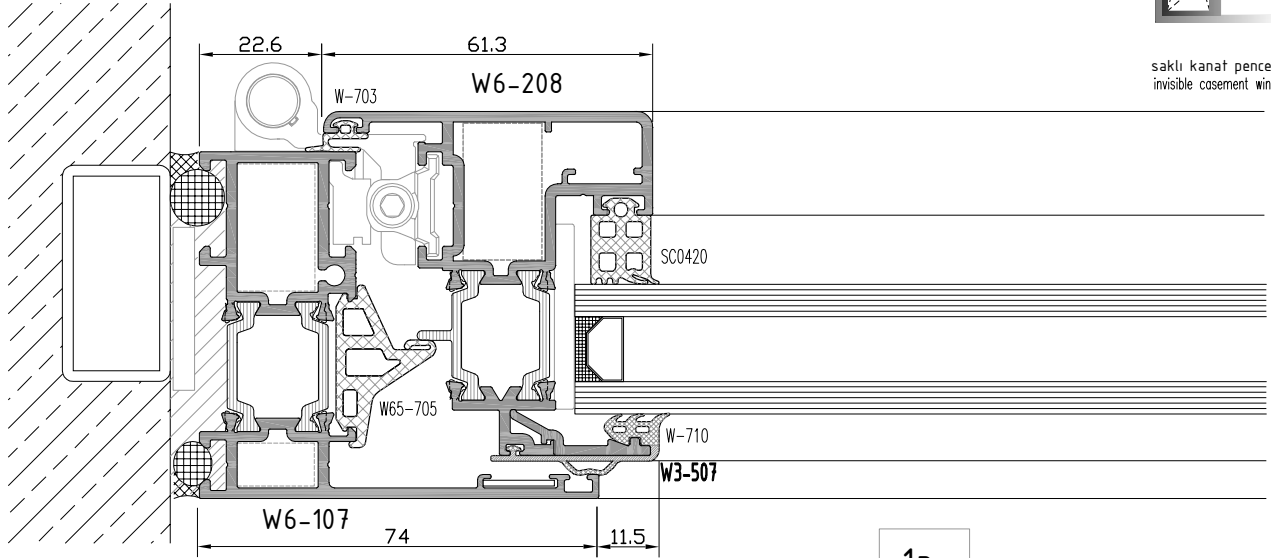

W6
W 65-2T YALITIMLI SERİ
W65-2T INSULATED SERIES

ORTA KAYIT DETAYI
MULLION DETAIL

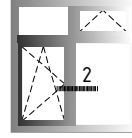

saklı kanat pencere
invisible casement window

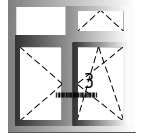

saklı kanat pencere
invisible casement window

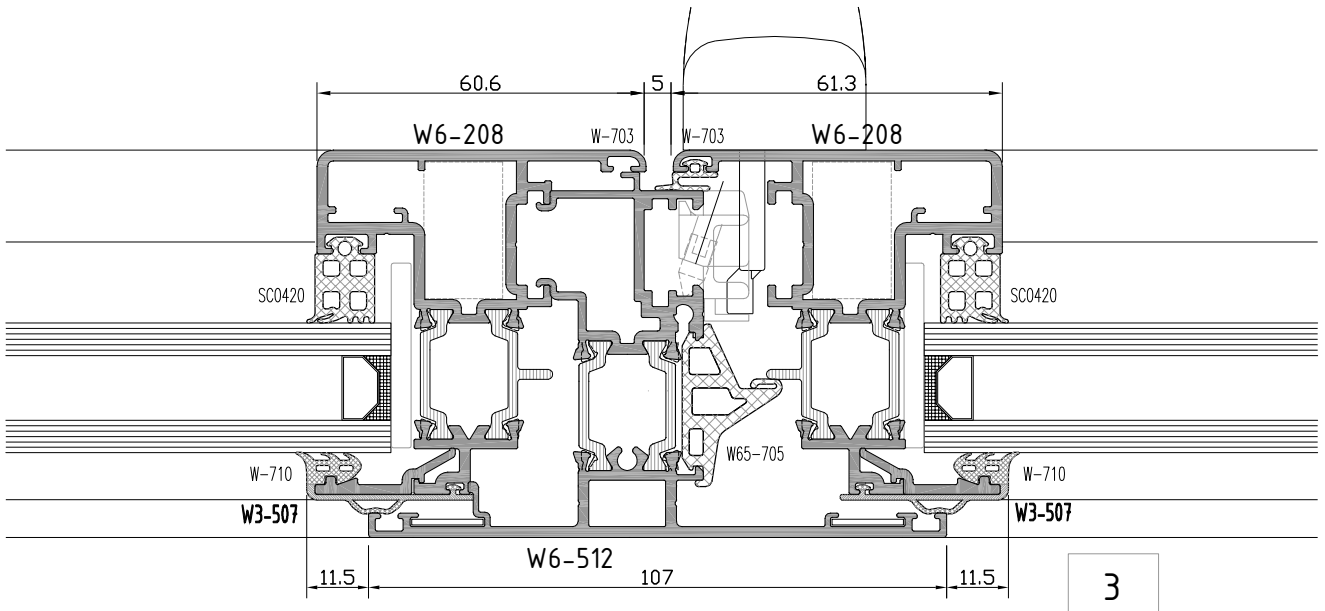
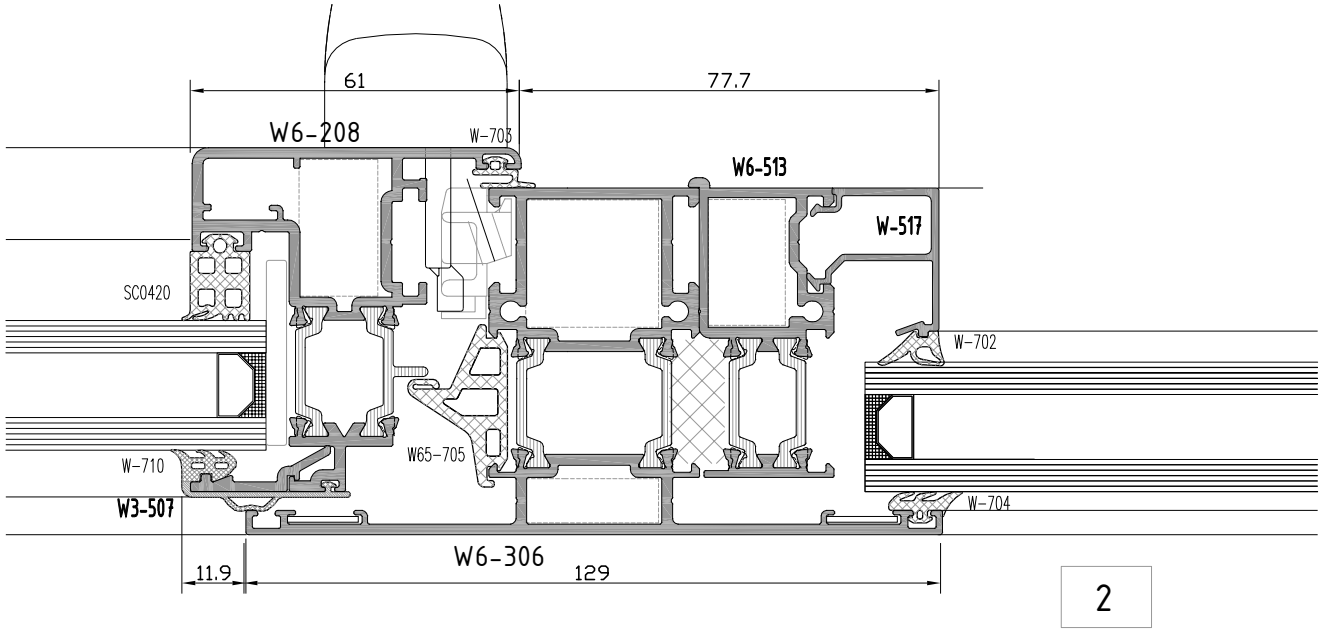

W6
W 65-2T YALITIMLI SERİ
W65-2T INSULATED SERIES

ORTA KAYIT-ALT BİTİM DETAYI
MULLION-BOTTOM EDGE DETAIL

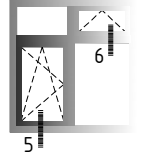

saklı kanat pencere
invisible casement window

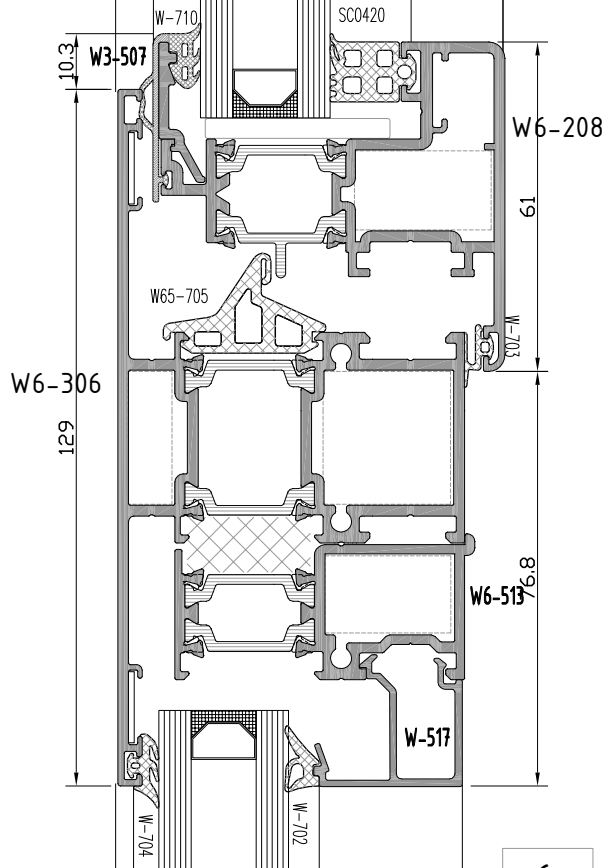
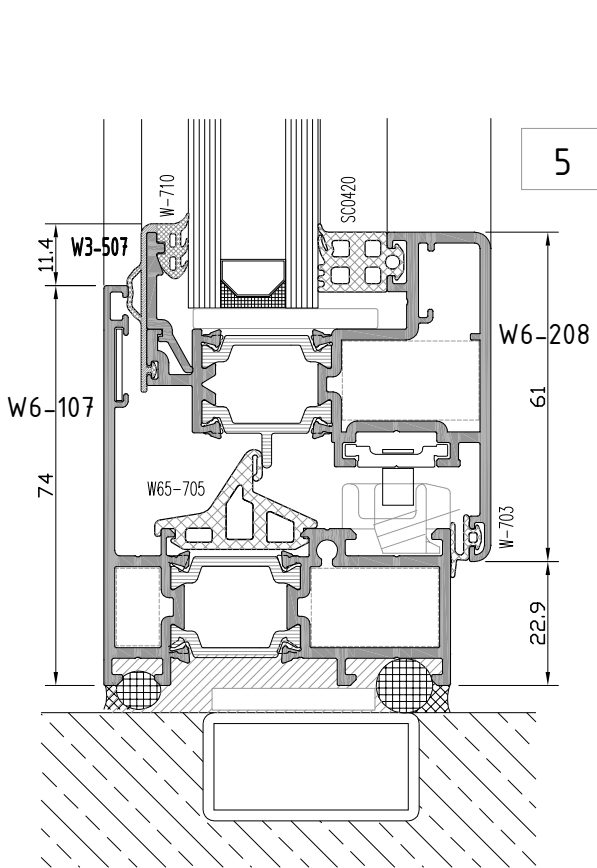

W6
W 65-2T YALITIMLI SERİ
 W65-2T INSULATED SERIES

YAN BİTİM-ORTA KAYIT DETAYI
 WALL CONNECTION-MULLION DETAIL

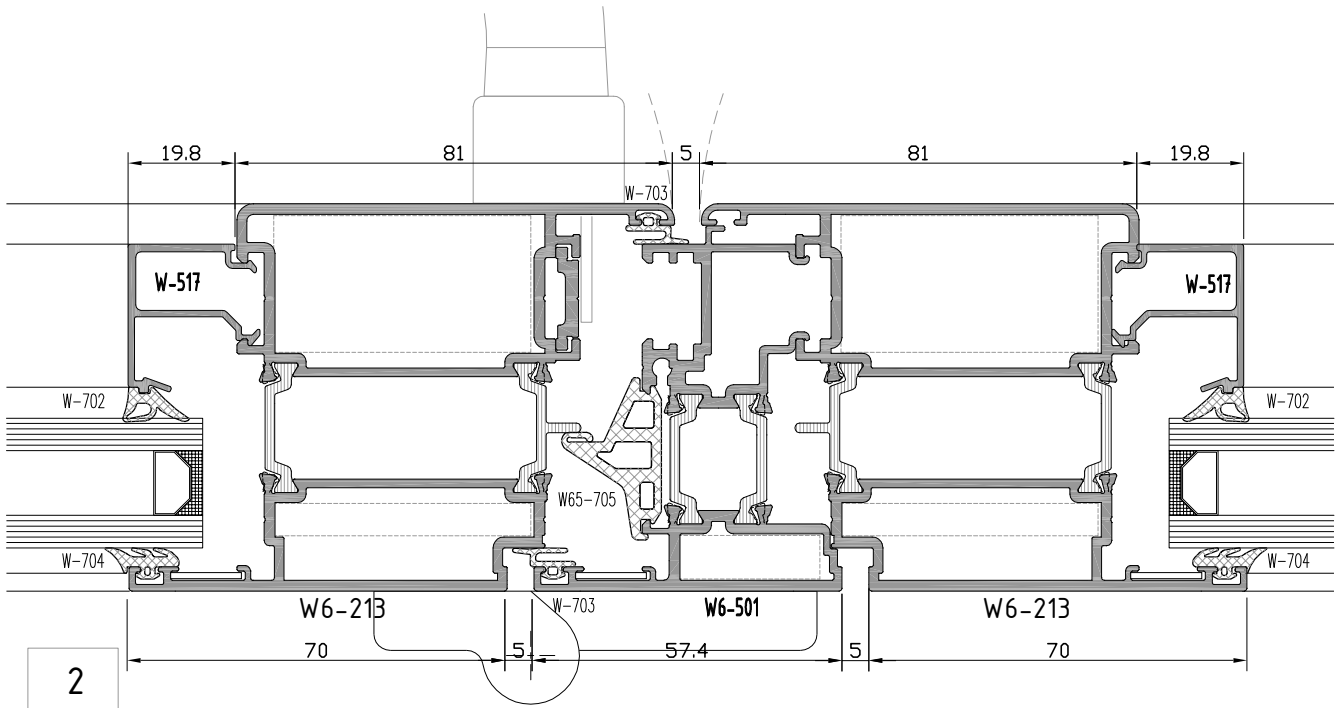
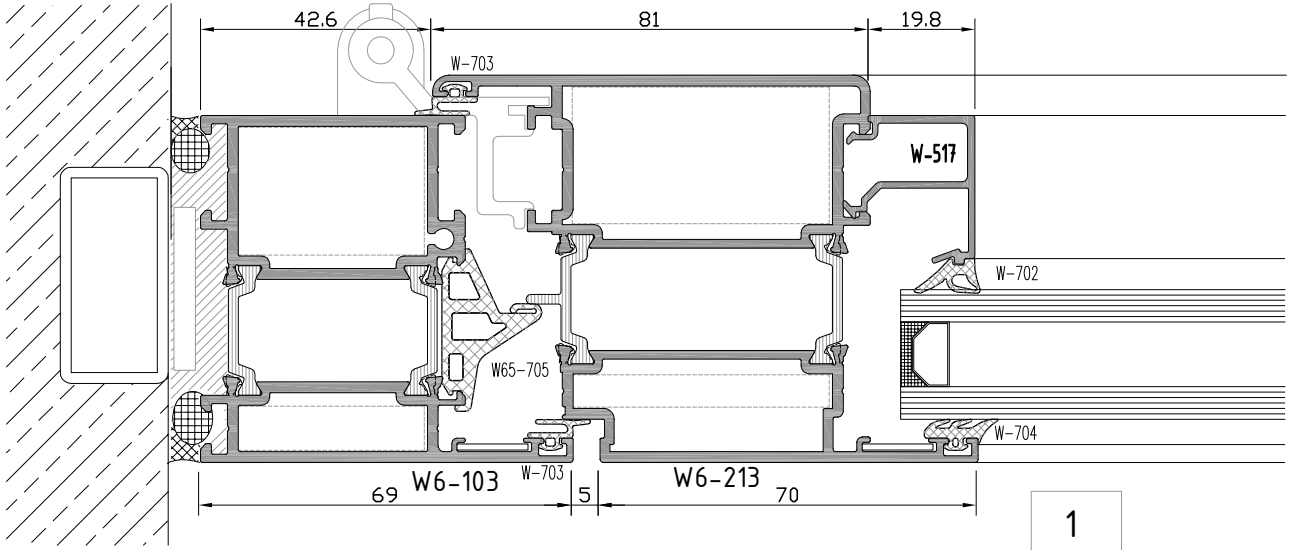
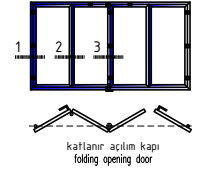

not to scale

W6
W 65-2T YALITIMLI SERİ
W65-2T INSULATED SERIES

KANAT BİRLEŞİM DETAYI
CASEMENT JOINING DETAIL

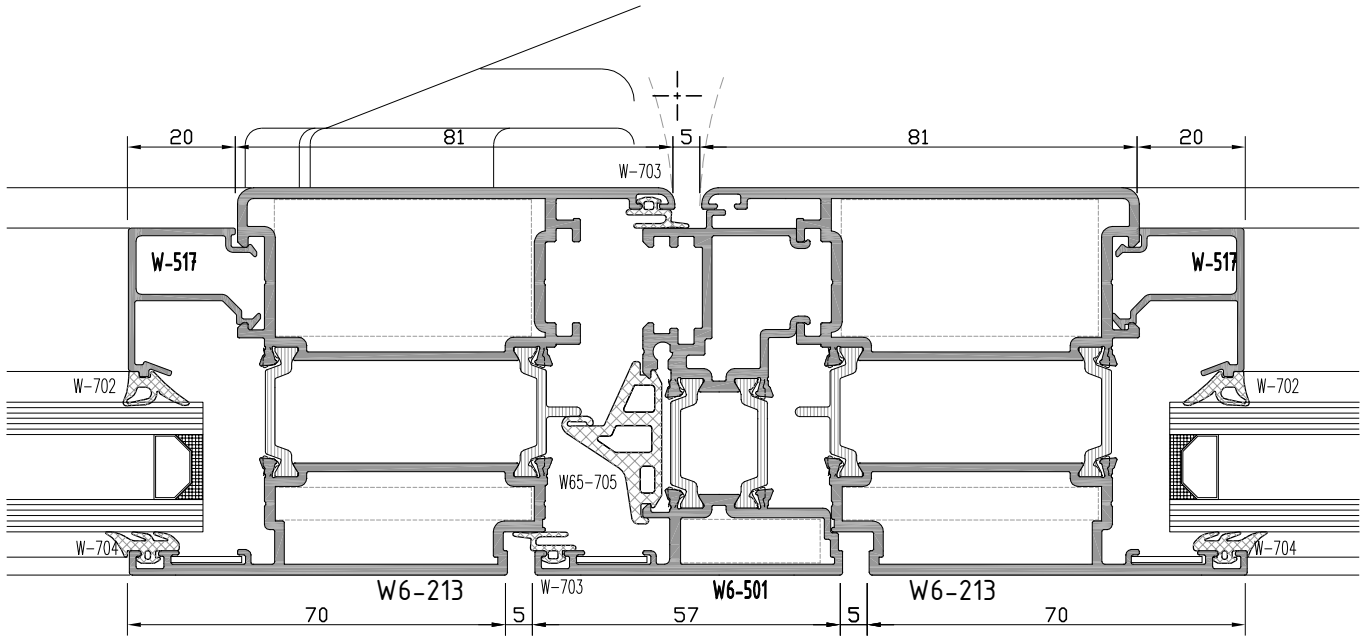
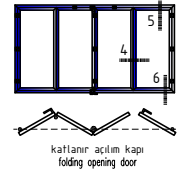

3

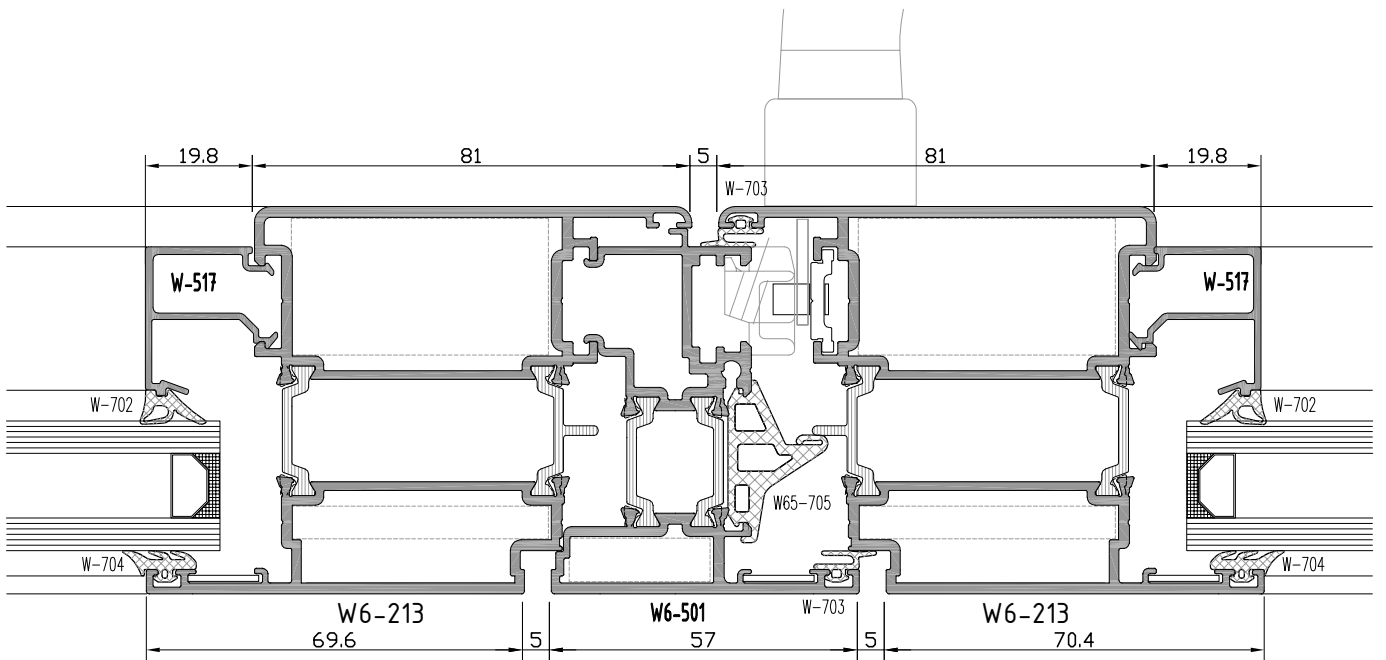

4

not to scale

W6
W 65-2T YALITIMLI SERİ
W65-2T INSULATED SERIES

ÜST-ALT BİTİM DETAYI
TOP EDGE-BOTTOM EDGE DETAIL

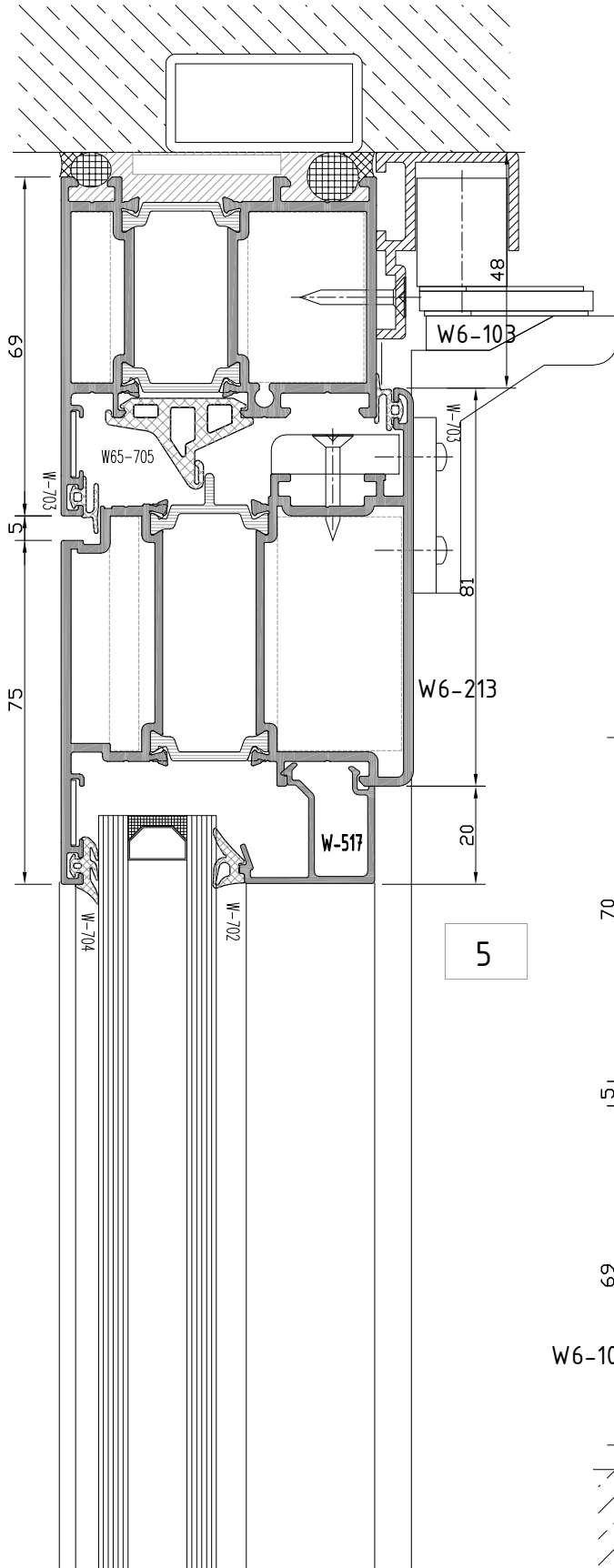
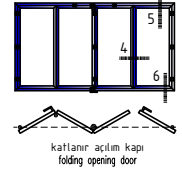

5

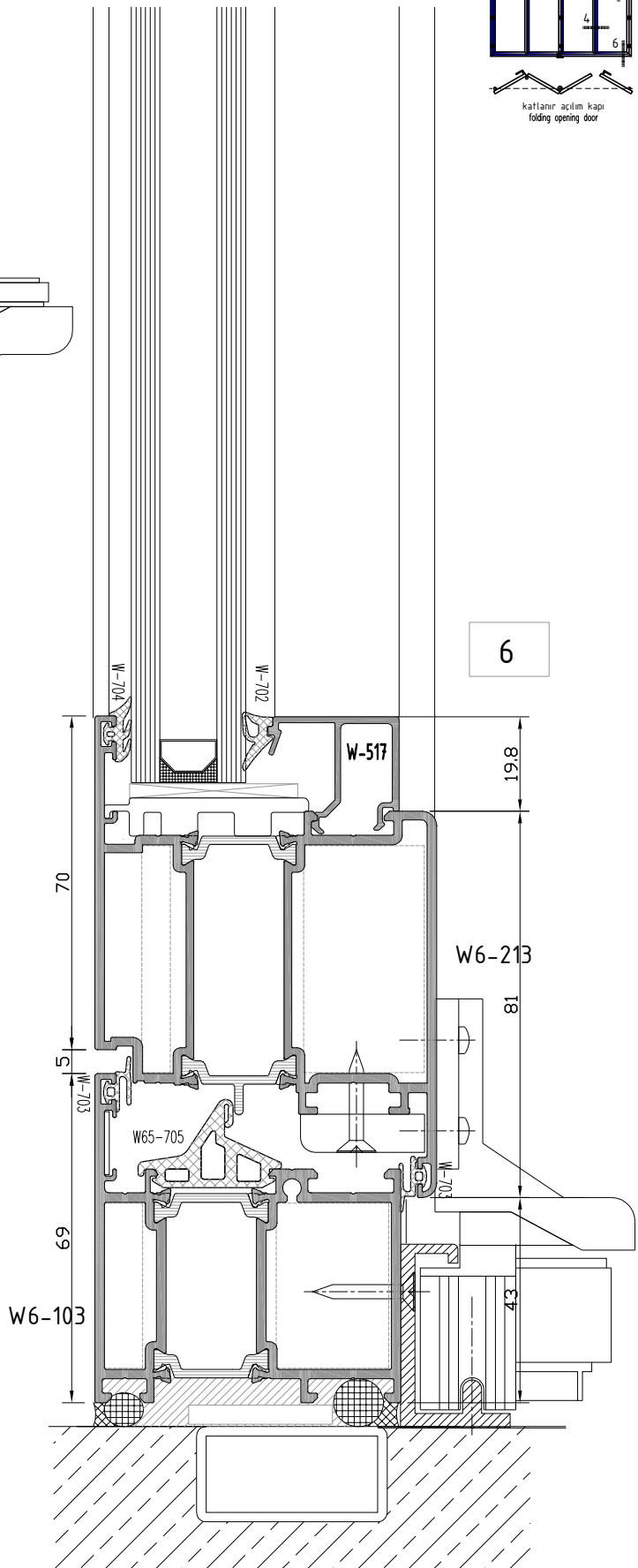

6

not to scale

W6
W 65-2T YALITIMLI SERİ
W65-2T INSULATED SERIES

CEPHE BİRLEŞİM DETAYI
FACADE SYSTEM MERGE DETAIL

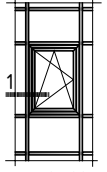

cephe içi
içe açılım pencere
inside opening casement
for facade sys.

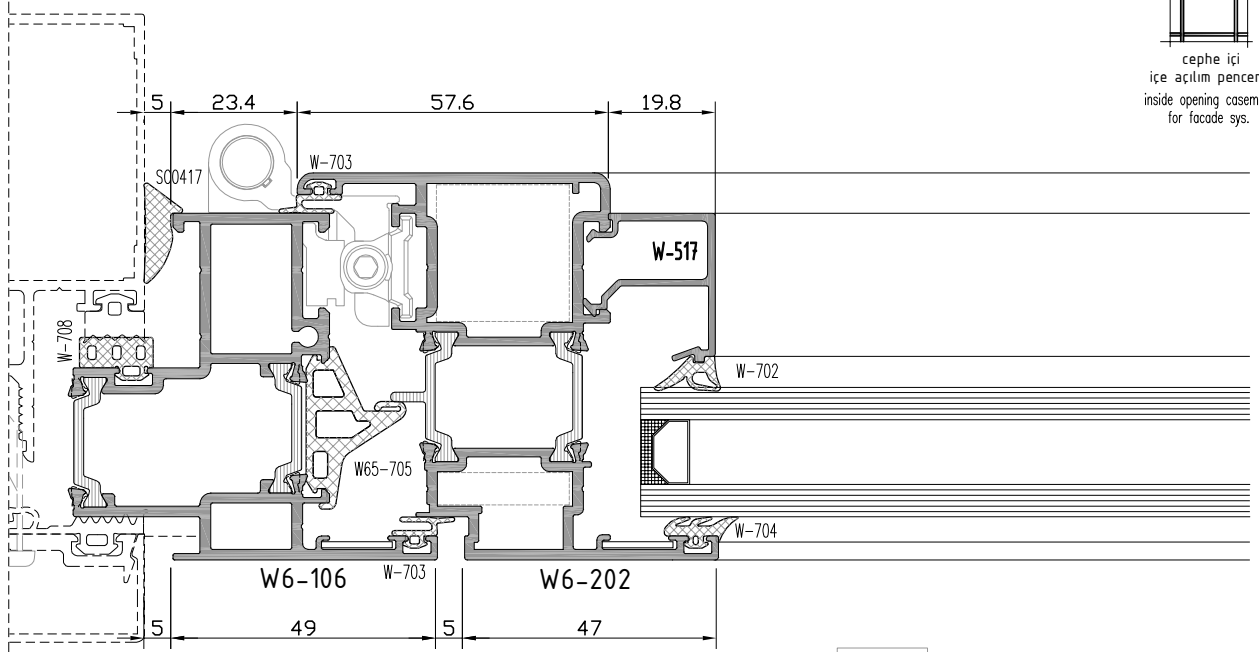

1a

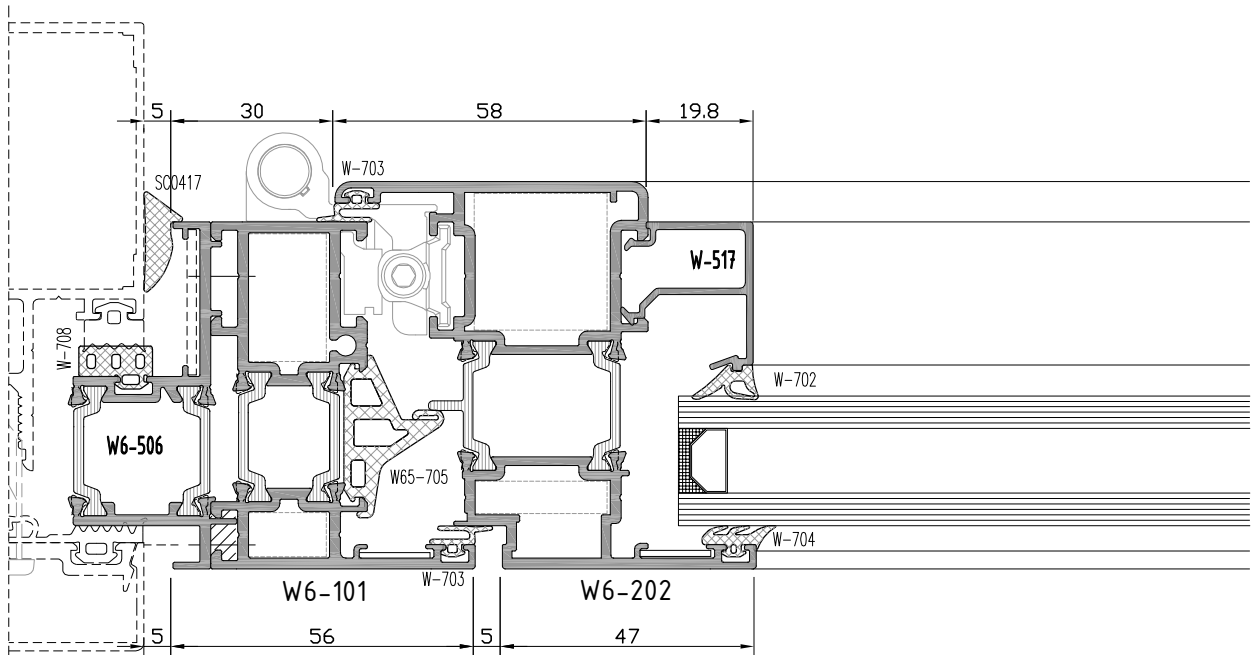

1b

not to scale

W6
W 65-2T YALITIMLI SERİ
W65-2T INSULATED SERIES

CEPHE BİRLEŞİM DETAYI
FACADE SYSTEM MERGE DETAIL

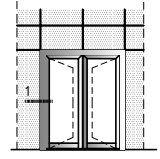

içe açılım kapı
inside opening door

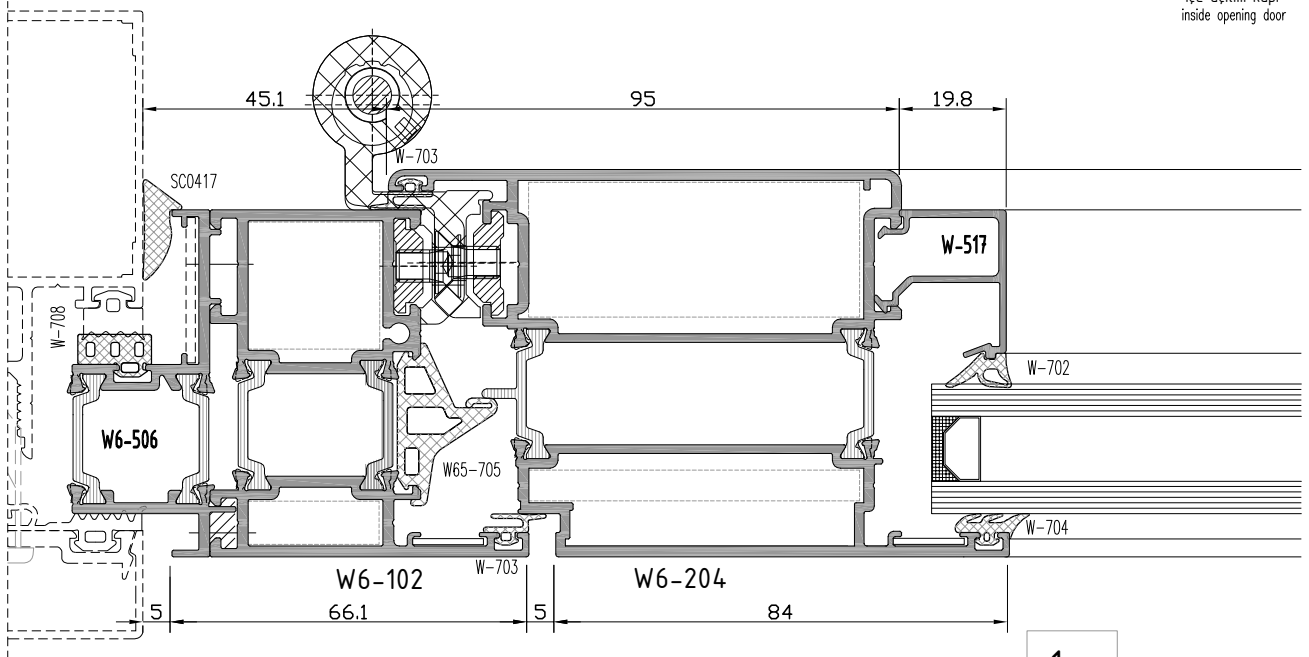

1a

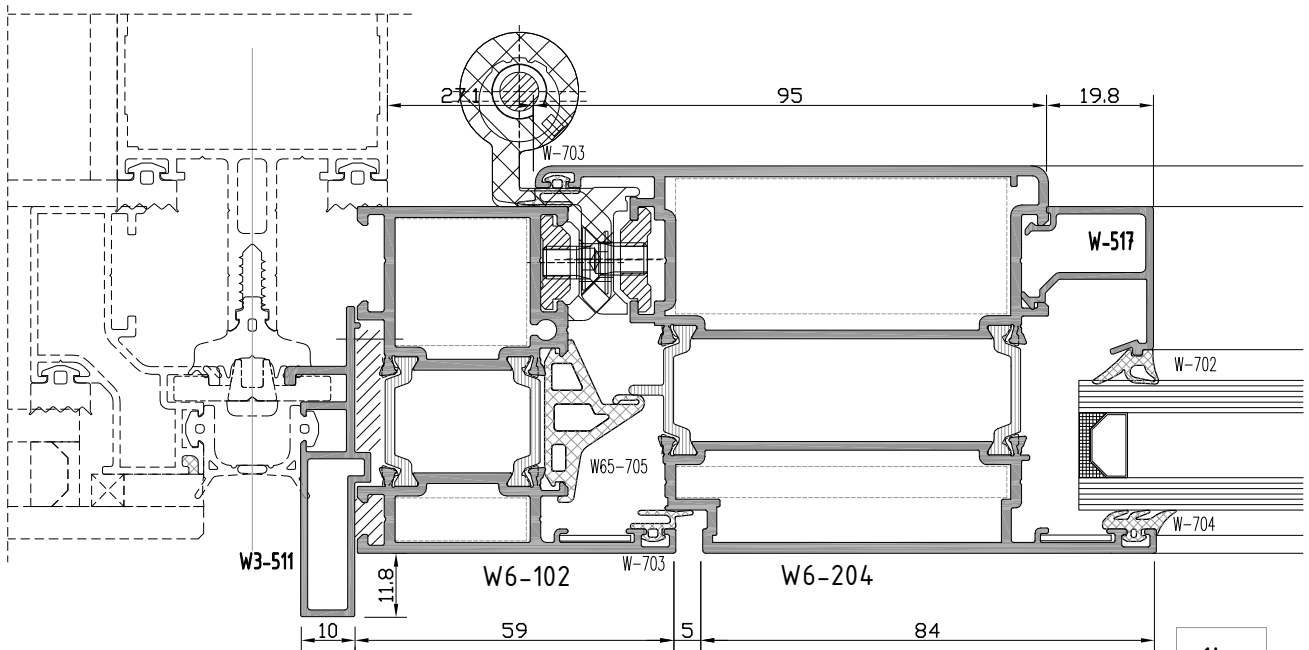

1b

not to scale

W6
W 65-2T YALITIMLI SERİ
W65-2T INSULATED SERIES

CEPHE BİRLEŞİM DETAYI
FACADE SYSTEM MERGE DETAIL

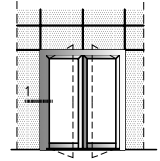

dışa açılım kapı
outside opening door

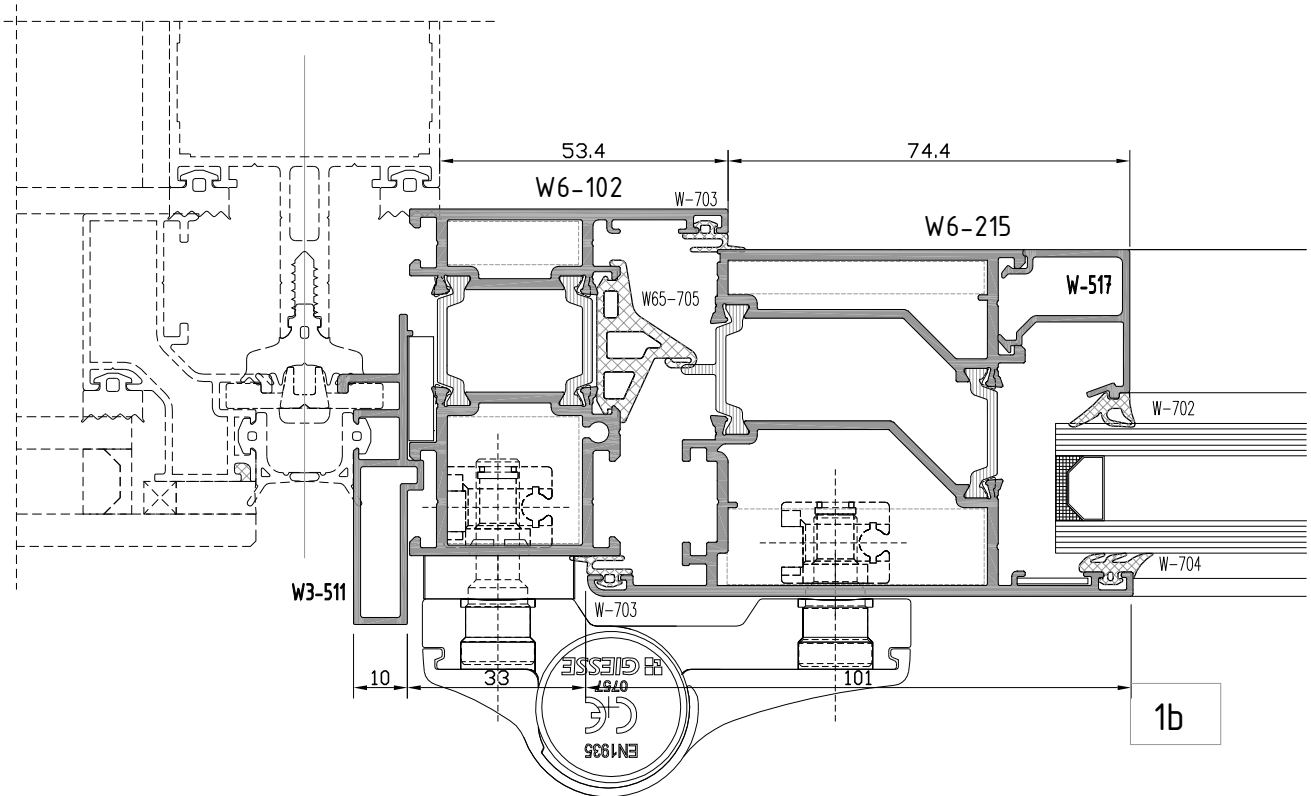
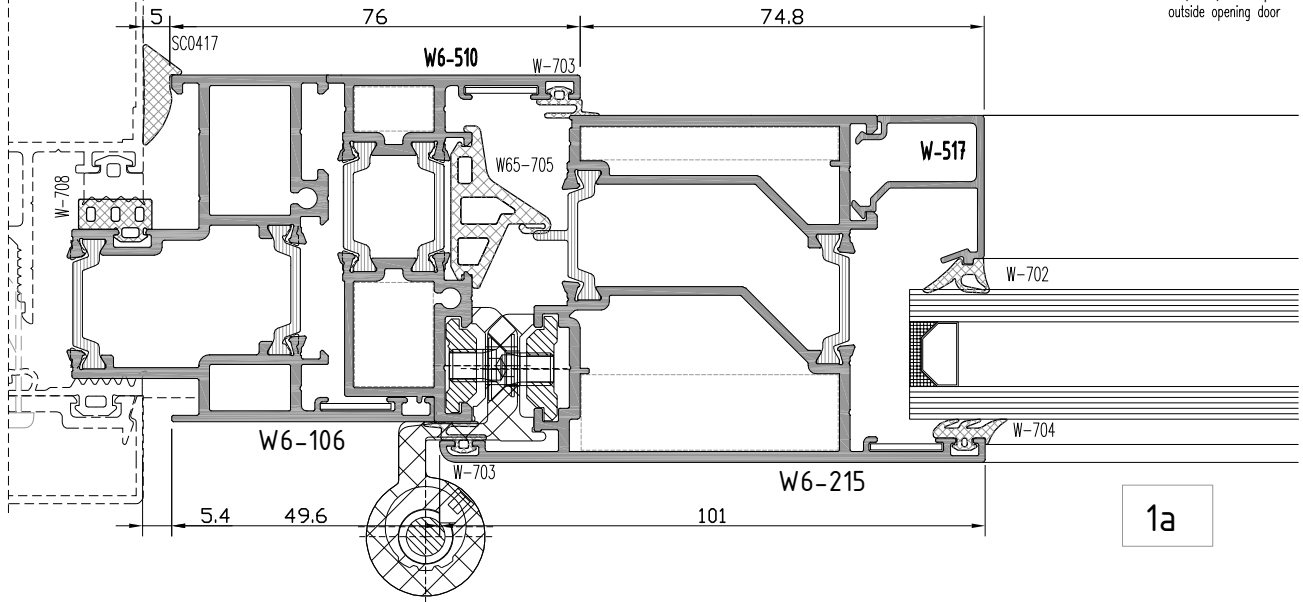

not to scale

W6

W 65 -2 T YALITIMLI SERİ

W65-2 T INSULATED SERIES

İMALAT ŞEMASI

PRODUCTION PLAN

NORMAL / VAŞİSTAS / ÇİFT AÇILIM PENCERE

NORMAL / TILT / TILT & TURN WINDOW

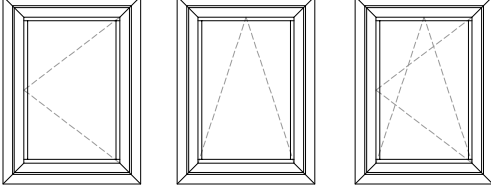

$$K1 = X + 12$$

$$K2 = Y + 12$$

$$G = B + 28$$

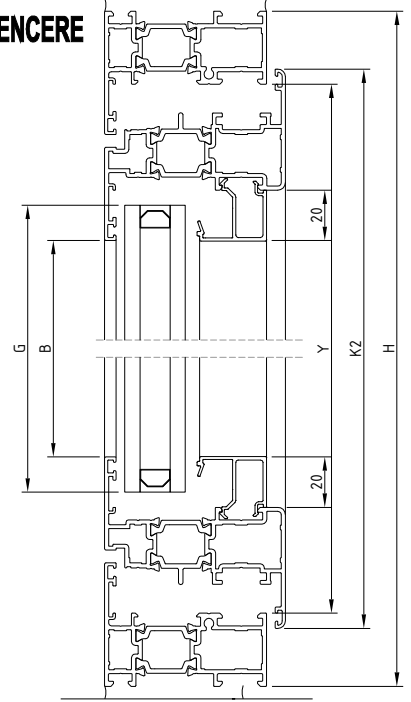
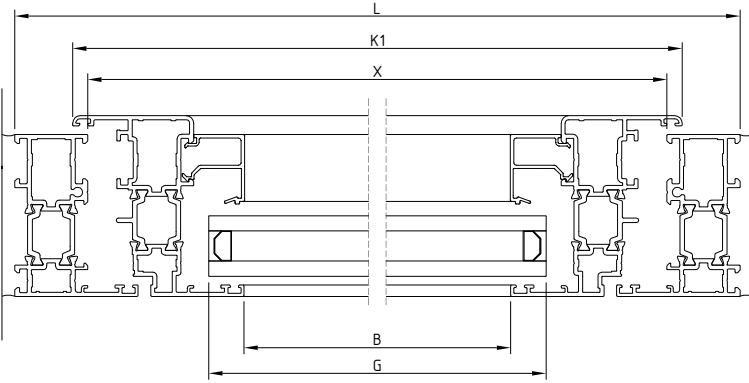

NORMAL / NORMAL VE ÇİFT AÇILIM / WOSVAGEN AÇILIM PENCERE

NORMAL / TILT & TURN END SIDE HUNG / WOSVAGEN WINDOW

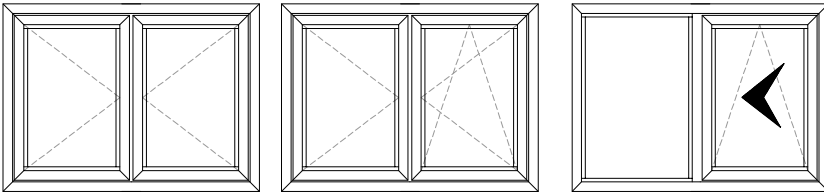

$$K1 = \frac{X + 12 - 5}{2}$$

$$K2 = Y + 12$$

$$G = B + 28$$

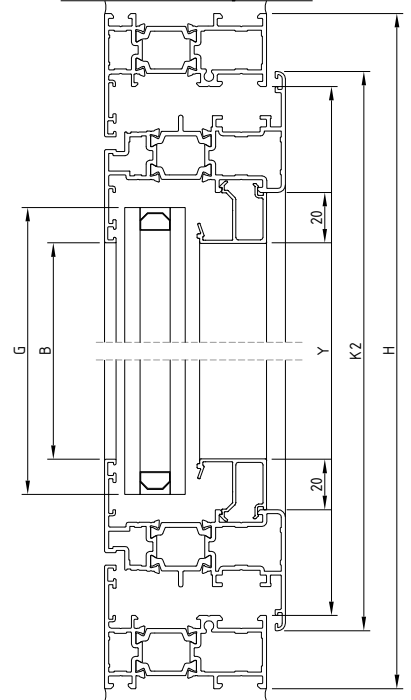
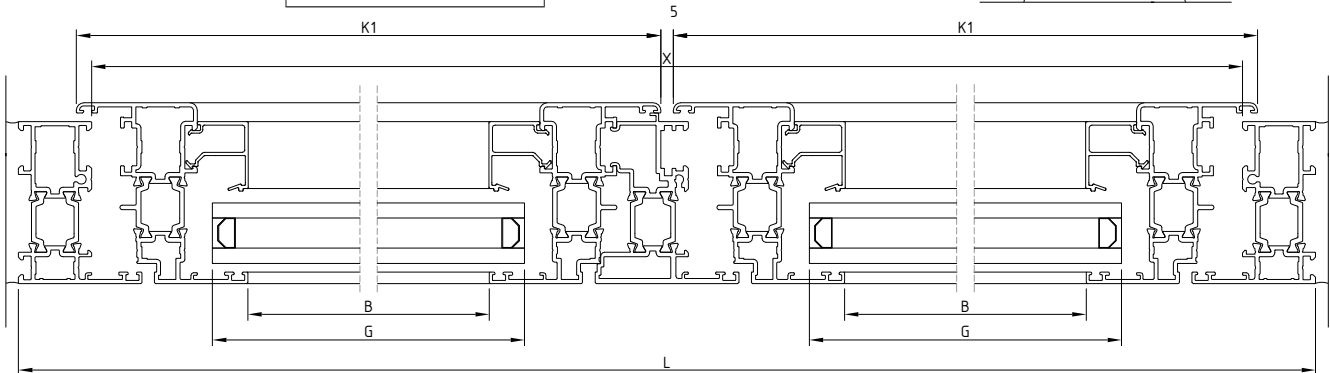

W6

W 65 -2 T YALITIMLI SERİ W65-2 T INSULATED SERIES

İMALAT ŞEMASI PRODUCTION PLAN

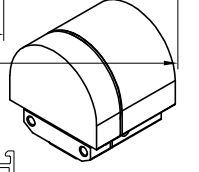
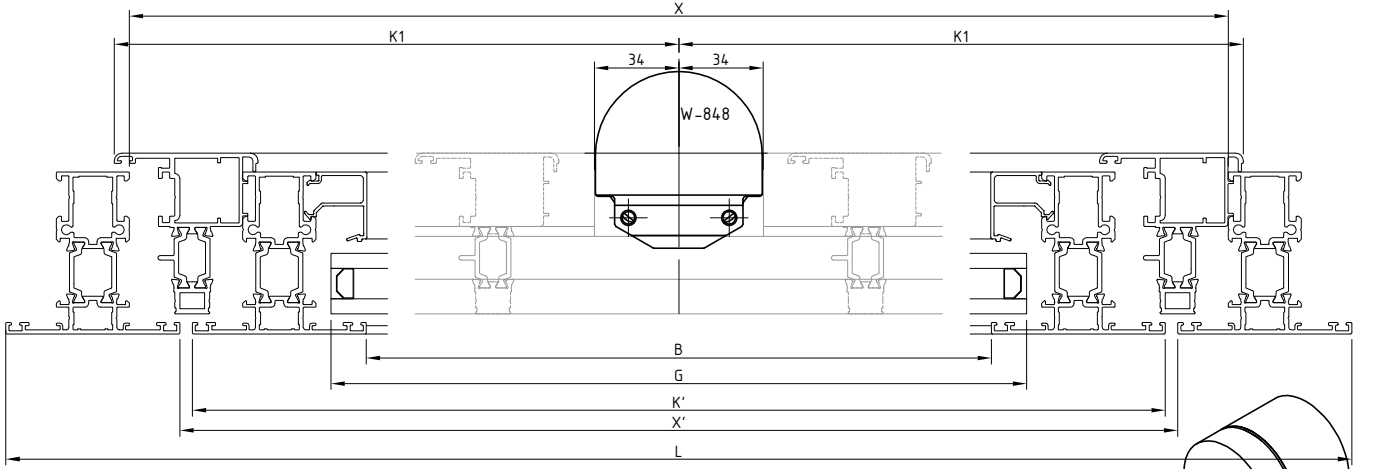

$$K1 = \frac{X - 67 + 12}{2}$$

$$K2 = Y + 12$$

$$G = B + 28$$

$$K' = X' - 10$$

$$K = Y + 6 \text{ özel işlemlı}$$

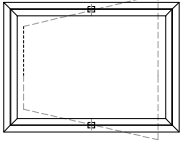
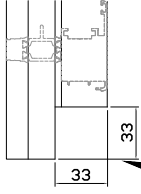

PIVOT AÇILIM PENCERE
PIVOT WING OPENING WINDOW

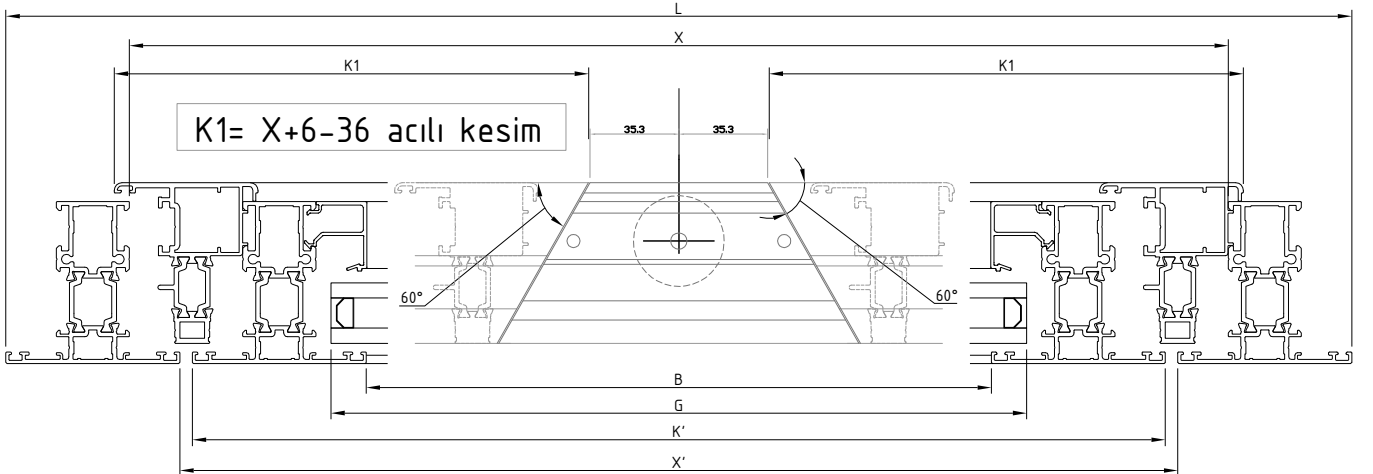
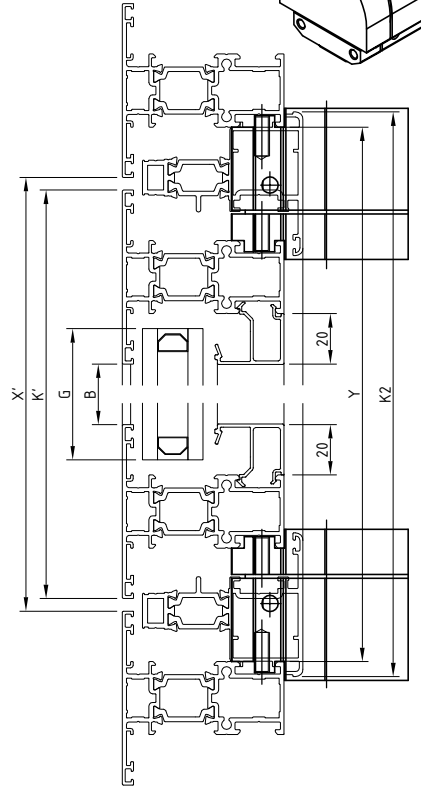
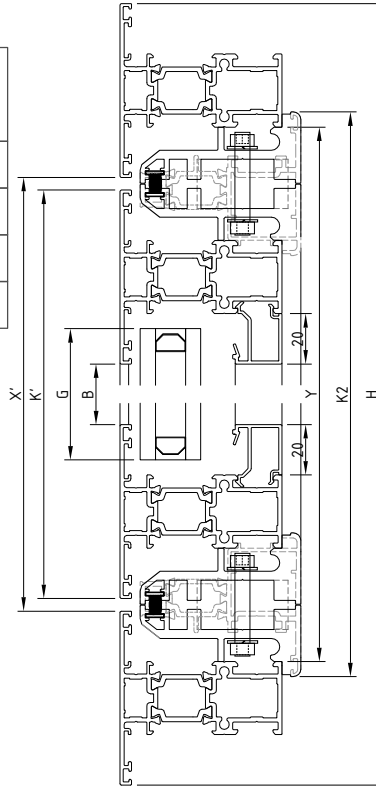

W6

W 65 -2 T YALITIMLI SERİ

W65-2 T INSULATED SERIES

İMALAT ŞEMASI

PRODUCTION PLAN

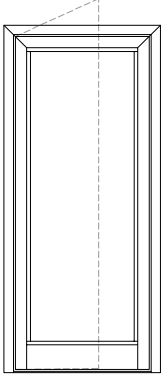

İCERİ ACILAN KAPI
INTSIDE OPENING DOOR

$$K1 = X + 12$$

$$K2 = Y + 6 - 15$$

$$G = B + 28$$

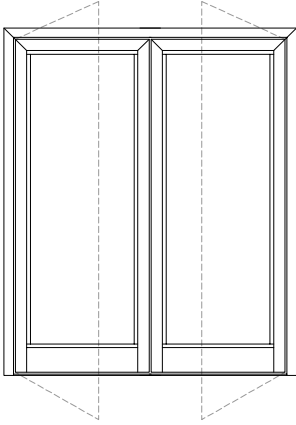
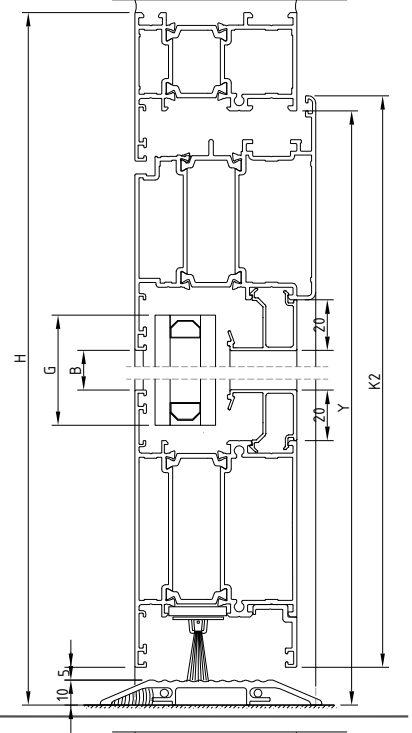
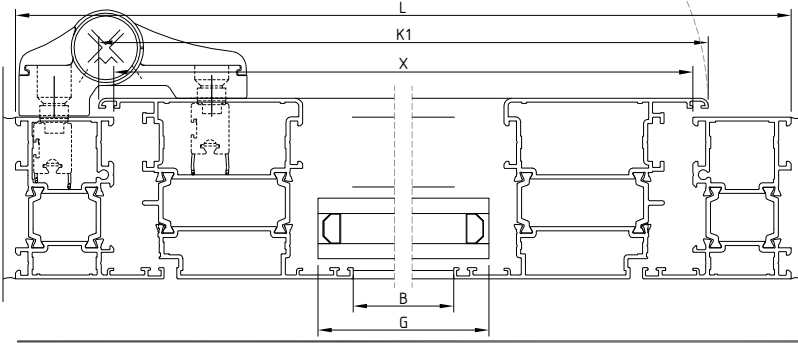

ÇİFT KANAT İCERİ ACILAN KAPI
DOUBLE INTSIDE OPENING DOOR

$$K1 = \frac{X + 12 - 5}{2}$$

$$K2 = Y + 6 - 15$$

$$G = B + 28$$

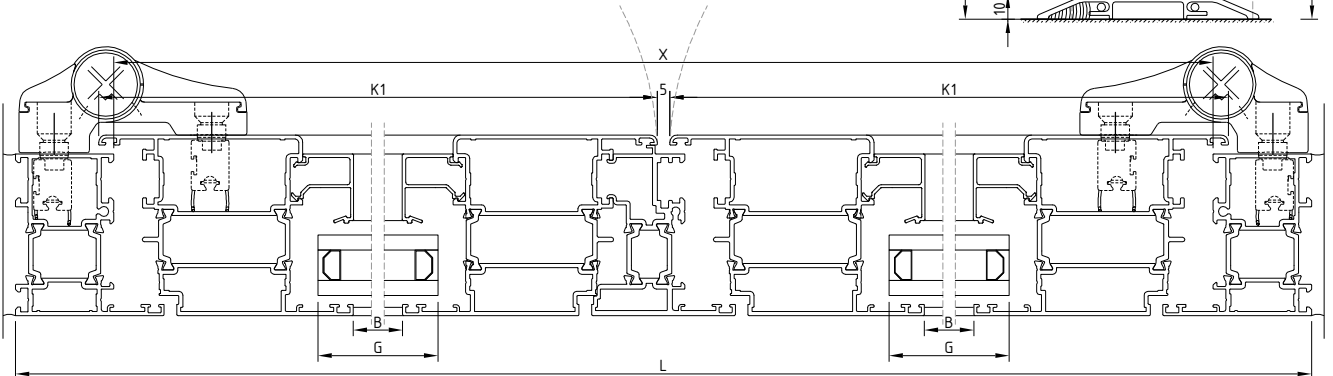
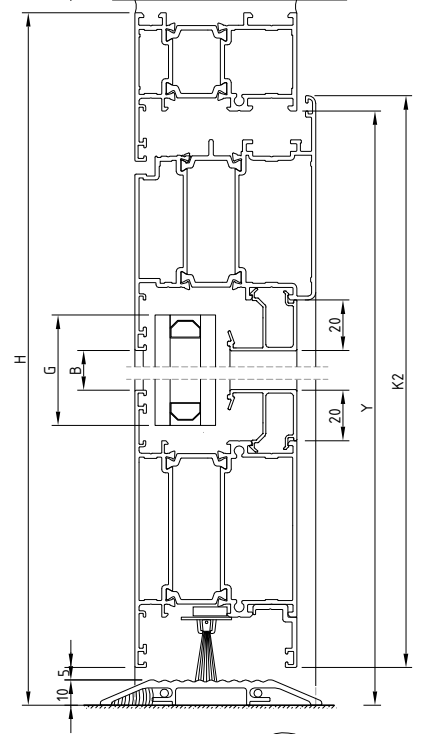

W6

W 65 -2 T YALITIMLI SERİ
W65-2 T INSULATED SERIES

İMALAT ŞEMASI
PRODUCTION PLAN

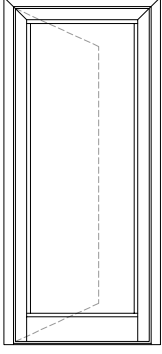

DIŞA AÇILAN KAPI
OUTSIDE OPENING DOOR

$$K1 = X + 12$$

$$K2 = Y + 6 - 15$$

$$G = B + 28$$

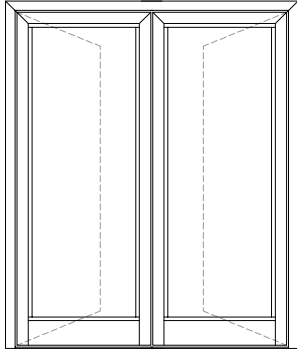
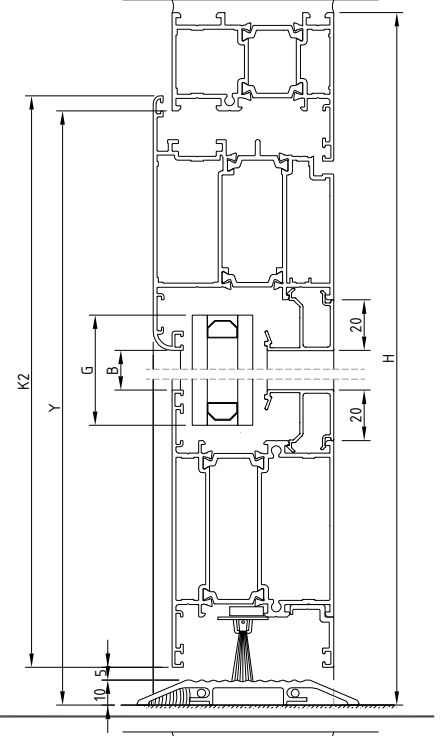
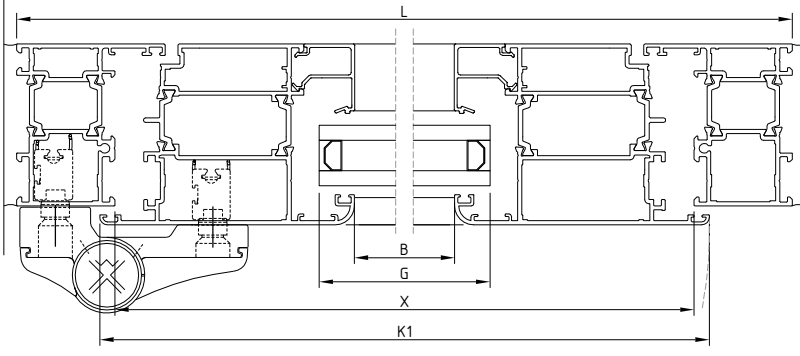

ÇİFT KANAT DIŞARI AÇILAN KAPI
DOUBLE OUTSIDE OPENING DOOR

$$K1 = \frac{X + 12 - 5}{2}$$

$$K2 = Y + 6 - 15$$

$$G = B + 28$$

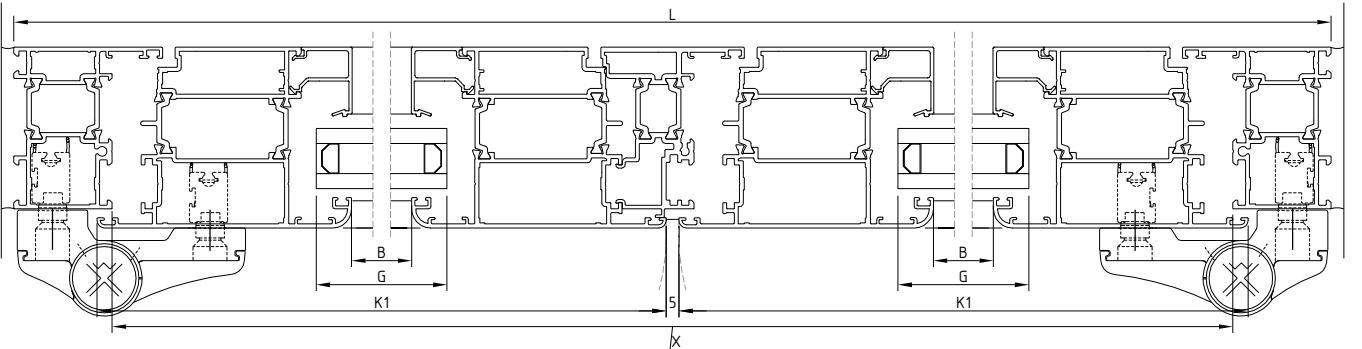
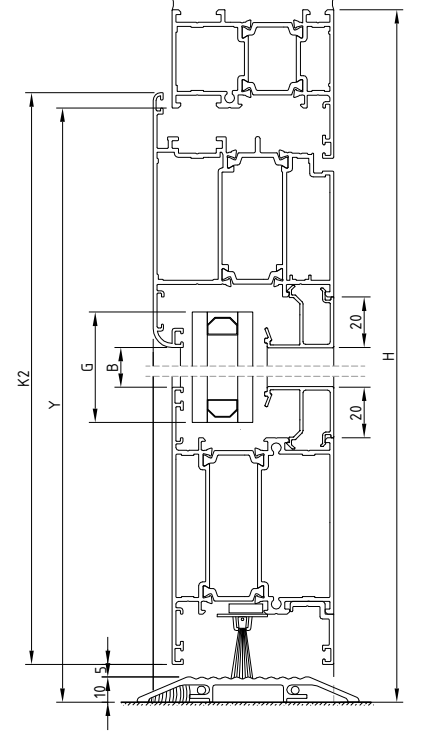

W 65 SERİ PROFİLLERİ

W65 PROFILES SERIE

Fitil listesi

Gasket list

kod code	şekil drawing	tanım description	teorik ağırlık teoretical weight gr / m	paket ağırlığı package weight kg / package	paket metrajı in one package metre / package	kullanım yeri aplication
W-701		epdm cam iç fitil glazing gasket inside	41 gr/m	15 kg	366 m	
W-702		epdm cam iç fitil glazing gasket inside	49 gr/m	15 kg	306 m	
W-703		epdm çarpma iç-dış fitil glazing acoustical (epdm)	33 gr/m	15 kg	440 m	
W-704		epdm cam dış fitil glazing gasket outside (epdm)	50 gr/m	15 kg	300 m	
W65-705		epdm tozluk fitil central gasket (epdm)	221,5 gr/m	15 kg	68 m	
W65-706		köşe tozluk fitil central gasket (epdm)	25,5 gr/m	-	50 ad-pcs	

W 65 SERİ PROFİLLERİ

W65 PROFILES SERIE

Fıtıl listesi

Gasket list

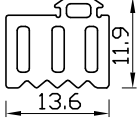
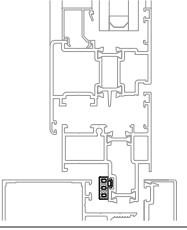
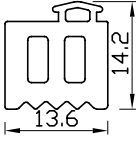
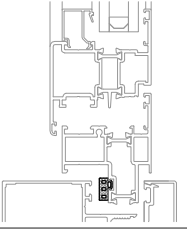
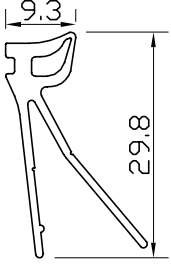
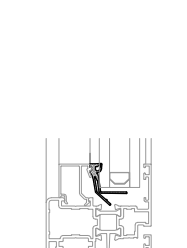
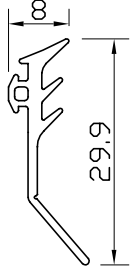
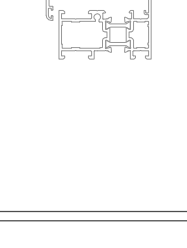
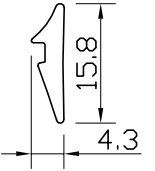
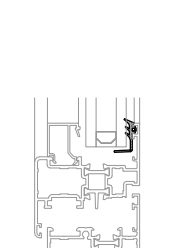
kod code	şekil drawing	tanım description	teorik ağırlık theoretical weight gr / m	paket ağırlığı package weight kg / package	paket metraji in one package metre / package	kullanım yeri aplication
W-713		Profil iç fitil Profile gasket inside	135 gr/m	15 kg	110 m	
W-714		Profil iç fitil Profile gasket inside	166 gr/m	15 kg	90 m	
W-715		epdm cam iç fitil glazing gasket inside	119 gr/m	15 kg	126 m	
W-716		epdm cam dış fitil glazing gasket outside (epdm)	77 gr/m	15 kg	195 m	
W-718		epdm cam iç fitil glazing gasket inside	52 gr/m	15 kg	288 m	

W 65 SERİ PROFİLLERİ

W65 PROFILES SERIE

Fıtıl listesi

Gasket list

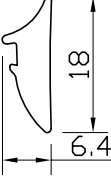
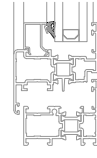
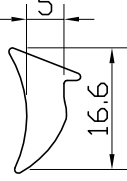
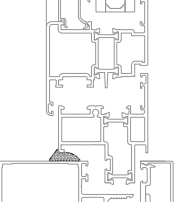
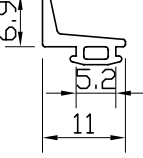
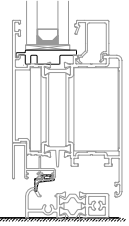
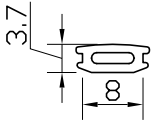
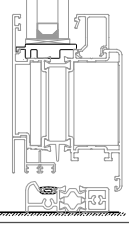
kod code	şekil drawing	tanım description	teorik ağırlık theoretical weight gr / m	paket ağırlığı package weight kg / package	paket metrajı in one package metre / package	kullanım yeri aplication
W-719		epdm cam iç fıtıl glazing gasket inside	88 gr/m	15 kg	170 m	
SC0417		kasa alt fıtıl safe gasket inside (epdm)	96 gr/m	15 kg	156 m	
W-721		Eşik Fıtılı gasket threshold profile	40 gr/m	15 kg	375 m	
W-722		Eşik Fıtılı gasket threshold profile	30 gr/m	15 kg	500 m	

AKSESUARLAR ACCESSOIRES

PENCERE VE KAPI AÇILIM MEKANİZMALARI WINDOW AND DOOR OPENING MECHANISMS

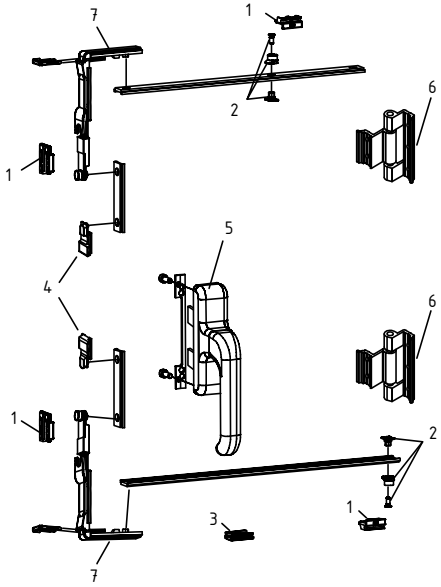

Normal açılım mekanizması (takım)
Opening window mechanism (set)

W-800		
1	Pim karşılığı	W-876
2	Ayarlı karşılık	W-879
3	Kanat sarkma takozu	W-887
4	Kol karşılığı	W-877
5	Çift dilli kol	W-857
6	Menteşe	W-833
+		
>1200 x 1400 mm		
7	Köşe dönme	W-875

W-801		
1	Pim karşılığı	W-876
2	Ayarlı karşılık	W-879
3	Kanat sarkma takozu	W-887
4	Kol karşılığı	W-877
5	Çift dilli kol	W-858
6	Menteşe	W-834
+		
>1200 x 1400 mm		
7	Köşe dönme	W-875

(renk seçeneği belirtilmelidir)
(colour choice must be stated)

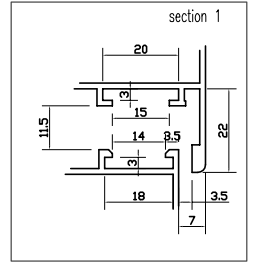
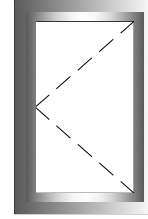

W-800 (ithal) (import) W-800-a (yerli) (native) naturel eloksalli (mat anodized)
W-801 (ithal) (import) W-801-a (yerli) (native) pres veya renkli (mill finish and painted)

Çift açılım mekanizması (takım)
Tilt and turn window mechanism (set)

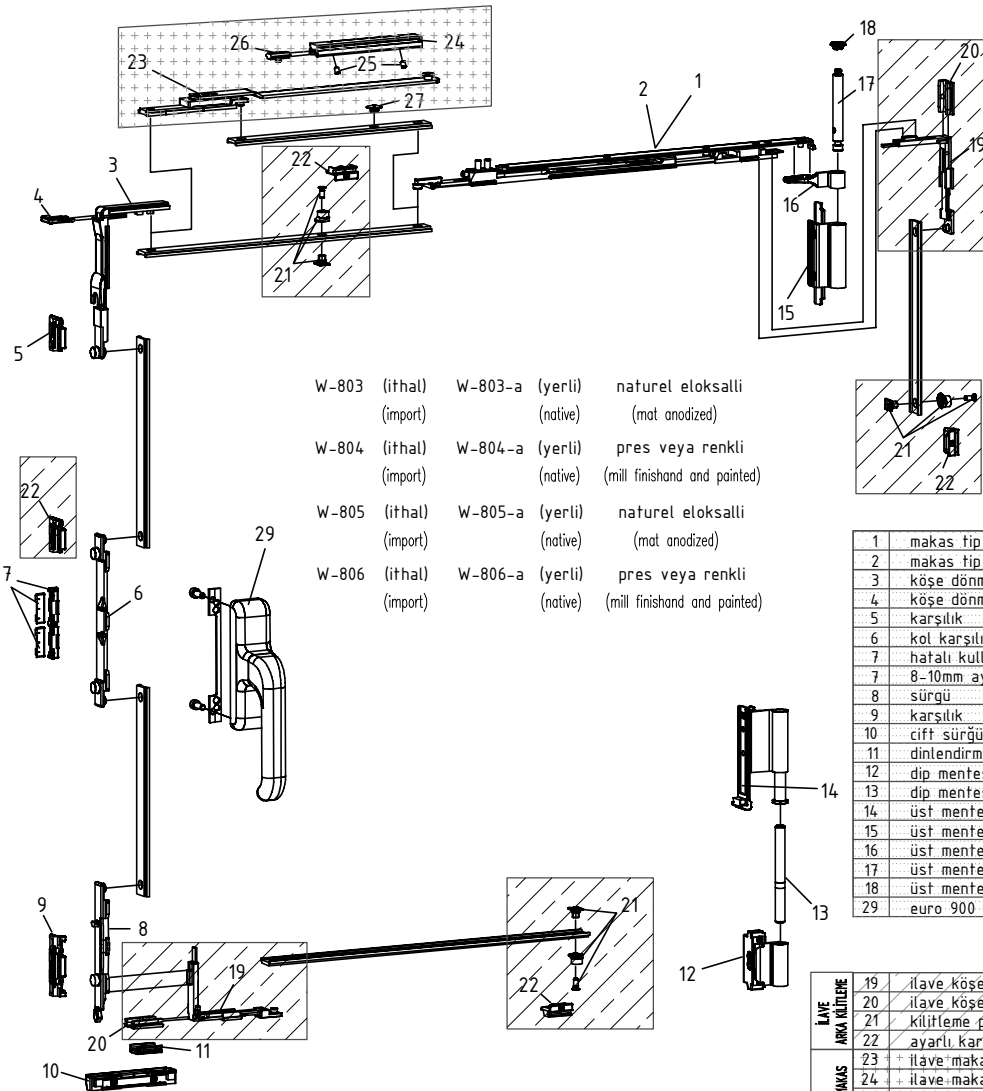

W-803 (ithal) (import) W-803-a (yerli) (native) naturel eloksalli (mat anodized)
W-804 (ithal) (import) W-804-a (yerli) (native) pres veya renkli (mill finish and painted)
W-805 (ithal) (import) W-805-a (yerli) (native) naturel eloksalli (mat anodized)
W-806 (ithal) (import) W-806-a (yerli) (native) pres veya renkli (mill finish and painted)

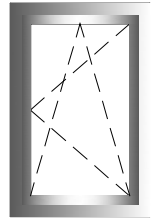
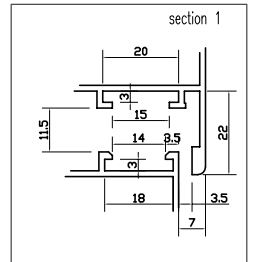

	W-805 (80 kg)	W-803 (130 kg)
1	makas tip 1 (küçük)	W-884-80 W-884-130
2	makas tip 2 (büyük)	W-881-80 W-881-130
3	köşe dönme	
4	köşe dönme sabitleme klipsi	
5	karşılık	
6	kol karşılığı	
7	hatalı kullanım öneme karşılığı	
8	8-10mm ayar şimi	W-803LOCK W-803LOCK
9	sürgü	
10	karşılık	
11	çift sürgü karşılık	
12	dinlendirme takozu	
13	dip menteşe erkek kısmı	
14	dip menteşe dişi kısmı	W-845HINGES W-842HINGES
15	üst menteşe erkek kısmı	
16	üst menteşe dişi kısmı	
17	üst menteşe pimi	
18	üst menteşe stoper kapak	
29	euro 900 çift açılım kolu	W-872 W-872

+
>80kg - 130kg

İLAVE ARKA KULLANILIR	İLAVE MAKAS		
19	ilave köşe dönme		
20	ilave köşe dönme sabitleme klipsi	W-880-1	W-880-1
21	kilitleme pimi		
22	ayarlı karşılık		
23	ilave makas		
24	ilave makas kılavuzu		
25	klavuz vidaları		W-880
26	ayarlı stoper		
27	makas destek bloğu		

AKSESUARLAR ACCESSOIRES

PENCERE VE KAPI AÇILIM MEKANİZMALARI WINDOW AND DOOR OPENING MECHANISMS

Locking mechanism UNI-JET C and D - Side hung fittings - 1 sash
Fixed gear position, groove position 9mm

Normal açılım PVC mekanizması (takım)
PVC opening window mechanism (set)

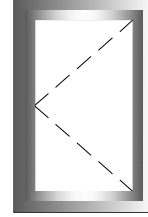

Basic security

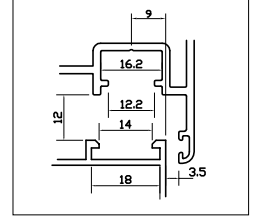

yükseklik (height):	kanat genişliği (width):					
	280-500	501-750	701-1000	1001-1200**	1201-1450**	1451-1600**
480-590	1	2	3	4	5	6
591-750	7	8	9	10	11	12
751-1200	13	14	15	16	17	18
951-1450 *	19	20	21	22	23	24
1201-1700 *	25	26	27	28	29	30
1451-1950 *	31	32	33	34	35	36
1951-2450*	37	38	39	40	41	

* arka kilitlemeli
** yatay kilitlemeli

(renk seçeneği belirtilmelidir)
(colour choice must be stated)

W-807 (ithal) W-807-a (yerli) naturel eloksalli (import) (native) (mat anodized)
W-808 (ithal) W-808-a (yerli) pres veya renkli (import) (native) (mill finish and painted)

Örnek kod tesbiti
Example

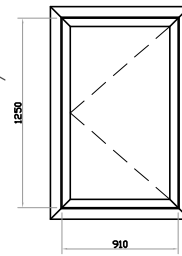

sipariş kodu
order code

W-807-27 (ithal) (import)

W-807-27-a (yerli) (native)

Locking mechanism UNI-JET C and D - Tilt-turn fittings - 1 sash
Fixed gear position, groove position 9mm

Çift açılım PVC mekanizması (takım)
PVC tilt and turn window mechanism (set)

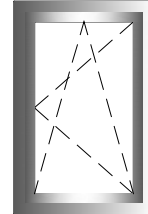

Basic security

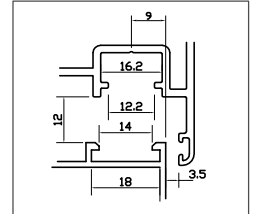

W-809 (ithal) W-809-a (yerli) naturel eloksalli (import) (native) (mat anodized)
W-810 (ithal) W-810-a (yerli) pres veya renkli (import) (native) (mill finish and painted)

yükseklik (height):	kanat genişliği (width):					
	280-500	501-750	701-1000	1001-1200**	1201-1450**	1451-1600**
480-590	1	2	3	4	5	6
591-750	7	8	9	10	11	12
751-1200	13	14	15	16	17	18
951-1450 *	19	20	21	22	23	24
1201-1700 *	25	26	27	28	29	30
1451-1950 *	31	32	33	34	35	36
1951-2450*	37	38	39	40	41	

* arka kilitlemeli
** yatay kilitlemeli

(renk seçeneği belirtilmelidir)
(colour choice must be stated)

AKSESUARLAR ACCESSOIRES

PENCERE VE KAPI AÇILIM MEKANİZMALARI WINDOW AND DOOR OPENING MECHANISMS

Locking mechanism UNI-JET C and D Inactive sash fittings ZH
Fixed gear position, groove position 9mm



W-811	(ithal) (import)	W-811-a	(yerli) (native)	naturel eloksalli (mat anodized)
W-812	(ithal) (import)	W-812-a	(yerli) (native)	pres veya renkli (mill finishand and painted)

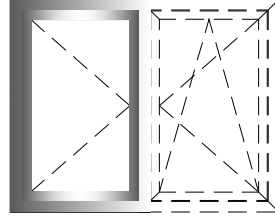

Basic security

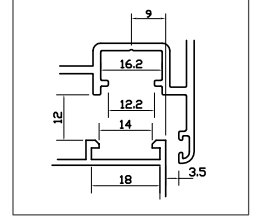

Normal açılım PVC mekanizması (takım)
PVC opening window mechanism (set)

kanat genişliği (width):

yükseklik (height):	kanat genişliği (width):					
	280-500	501-750	701-1000	1001-1200**	1201-1450**	1451-1600**
480-590	1	2	3	4	5	6
591-750	7	8	9	10	11	12
751-1200	13	14	15	16	17	18
951-1450 *	19	20	21	22	23	24
1201-1700 *	25	26	27	28	29	30
1451-1950 *	31	32	33	34	35	36
1951-2450*	37	38	39	40	41	

* arka kilitlemeli

** yatay kilitlemeli

(renk seçeneği belirtilmelidir)
(colour choice must be stated)

Locking mechanism UNI-JET C and D - Tilt-turn fittings - 2 sashes
Fixed gear position, groove position 9mm

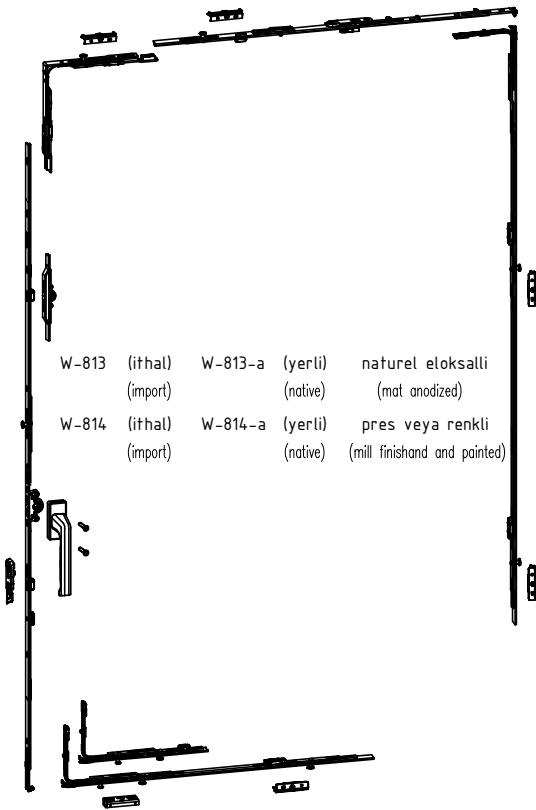

W-813	(ithal) (import)	W-813-a	(yerli) (native)	naturel eloksalli (mat anodized)
W-814	(ithal) (import)	W-814-a	(yerli) (native)	pres veya renkli (mill finishand and painted)

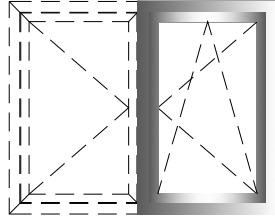

Basic security

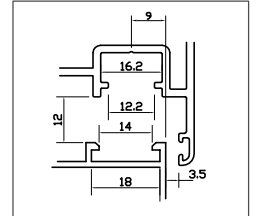

Çift açılım PVC mekanizması (takım)
PVC tilt and turn window mechanism (set)

kanat genişliği (width):

yükseklik (height):	kanat genişliği (width):					
	280-500	501-750	701-1000	1001-1200**	1201-1450**	1451-1600**
480-590	1	2	3	4	5	6
591-750	7	8	9	10	11	12
751-1200	13	14	15	16	17	18
951-1450 *	19	20	21	22	23	24
1201-1700 *	25	26	27	28	29	30
1451-1950 *	31	32	33	34	35	36
1951-2450*	37	38	39	40	41	

* arka kilitlemeli

** yatay kilitlemeli

(renk seçeneği belirtilmelidir)
(colour choice must be stated)

AKSESUARLAR ACCESSOIRES

PENCERE VE KAPI AÇILIM MEKANİZMALARI WINDOW AND DOOR OPENING MECHANISMS

Locking mechanism UNI-JET C and D - Side hung fittings - 2 sashes
Fixed gear position, groove position 9mm

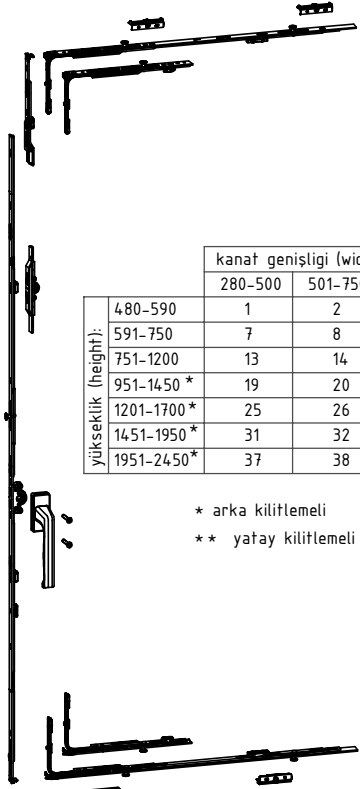

Normal açılım PVC mekanizması (takım)
PVC opening window mechanism (set)

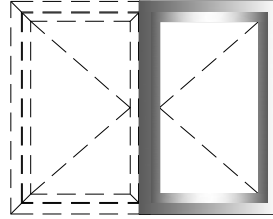

Basic security

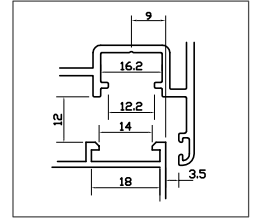

	kanat genişliği (width):					
	280-500	501-750	701-1000	1001-1200**	1201-1450**	1451-1600**
yükseklik (height):						
480-590	1	2	3	4	5	6
591-750	7	8	9	10	11	12
751-1200	13	14	15	16	17	18
951-1450 *	19	20	21	22	23	24
1201-1700 *	25	26	27	28	29	30
1451-1950 *	31	32	33	34	35	36
1951-2450*	37	38	39	40	41	

- W-815 (ithal) (import) W-815-a (yerli) (native) naturel eloksalli (mat anodized)
- W-816 (ithal) (import) W-816-a (yerli) (native) pres veya renkli (mill finishand and painted)

- * arka kilitlemeli
** yatay kilitlemeli

(renk seçeneği belirtilmelidir)
(colour choice must be stated)

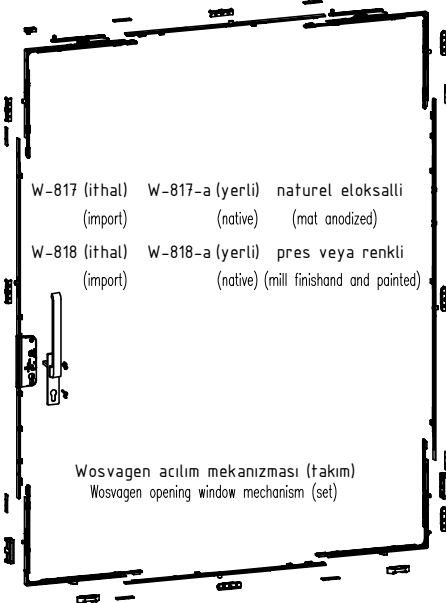
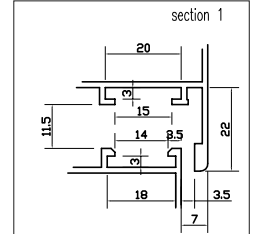
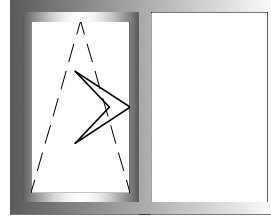

- W-817 (ithal) (import) W-817-a (yerli) (native) naturel eloksalli (mat anodized)
- W-818 (ithal) (import) W-818-a (yerli) (native) pres veya renkli (mill finishand and painted)

Wosvagen açılım mekanizması (takım)
Wosvagen opening window mechanism (set)

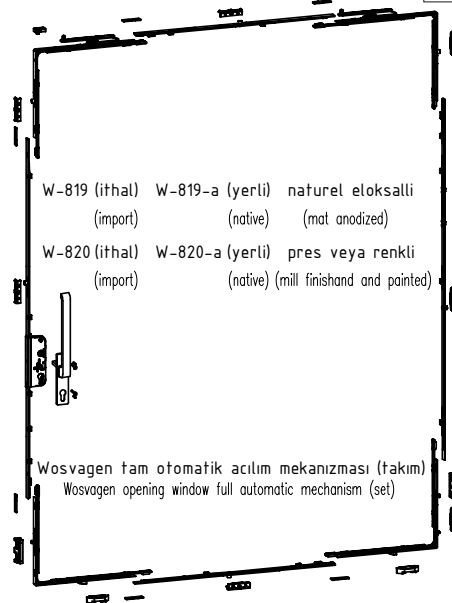

- W-819 (ithal) (import) W-819-a (yerli) (native) naturel eloksalli (mat anodized)
- W-820 (ithal) (import) W-820-a (yerli) (native) pres veya renkli (mill finishand and painted)

Wosvagen tam otomatik açılım mekanizması (takım)
Wosvagen opening window full automatic mechanism (set)

(renk seçeneği belirtilmelidir)
(colour choice must be stated)

AKSESUARLAR ACCESSOIRES

PENCERE VE KAPI AÇILIM MEKANİZMALARI WINDOW AND DOOR OPENING MECHANISMS

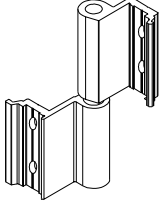

İki yapraklı pencere menteşesi
Two leaves window hinge

W-830 (ithal) (import)	W-830-a (yerli) (native)	naturel eloksalli (mat anodized)
W-831 (ithal) (import)	W-831-a (yerli) (native)	pres veya renkli (mill finishand and painted)

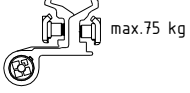

max.75 kg

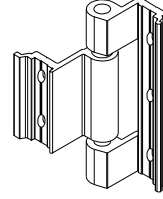

Üç yapraklı pencere menteşesi
Three leaves window hinge

W-833 (yerli) (native)	naturel eloksalli (mat anodized)
W-834 (yerli) (native)	pres veya renkli (mill finishand and painted)



max.75 kg

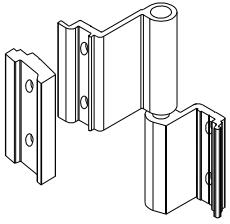

İki yapraklı normal açılım pvc pencere menteşesi
Two leaves PVC window hinge

W-836 (ithal) (import)	W-836-a (yerli) (native)	naturel eloksalli (mat anodized)
W-837 (ithal) (import)	W-837-a (yerli) (native)	pres veya renkli (mill finishand and painted)

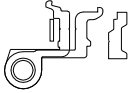

max.75 kg

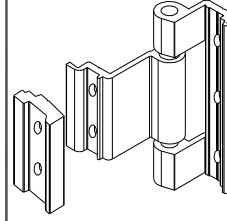

Üç yapraklı normal açılım pvc pencere menteşesi
Three leaves PVC window hinge

W-839 (yerli) (native)	naturel eloksalli (mat anodized)
W-840 (yerli) (native)	pres veya renkli (mill finishand and painted)

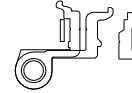

max.75 kg

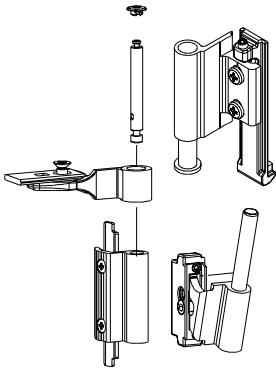

Çift açılım pencere üst menteşesi (130kg)
Tilt and turn window top hinge (130kg)

W-842HINGES (ithal) (import)	naturel eloksalli (mat anodized)
W-843HINGES (ithal) (import)	pres veya renkli (mill finishand and painted)

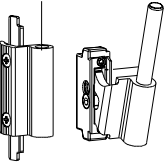

Çift açılım pencere üst menteşesi (80kg)
Tilt and turn window top hinge (80kg)

W-845HINGES (ithal) (import)	naturel eloksalli (mat anodized)
W-846HINGES (ithal) (import)	pres veya renkli (mill finishand and painted)

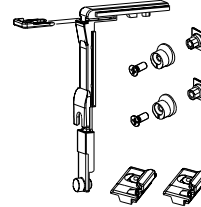

ÇİFT AÇILIM İLAVE KİLİTLEME
TILT AND TURN ANNEX SET

W-880-1 (ithal) (import)

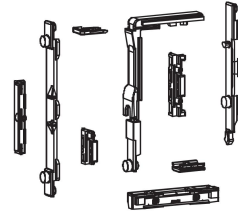

ÇİFT AÇILIM KİLİTLEME MEKANİZMA
TILT AND TURN BASE MECHANISM

W-803LOCK (ithal) (import)

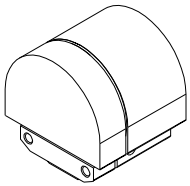

Pivot menteşe
Hung window hinge

W-848 (ithal) (import)	W-848-a (yerli) (native)	naturel eloksalli (mat anodized)
W-849 (ithal) (import)	W-849-a (yerli) (native)	pres veya renkli (mill finishand and painted)

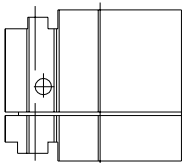

Pivot menteşe
Hung window hinge

W-851 (yerli) W-852 (yerli)	naturel eloksalli pers-renkli boyalı	W1-W2-W3-W4
W65-851 (yerli) W65-852 (yerli)	naturel eloksalli pers-renkli boyalı	W5-W6
W75-851 (yerli) W75-852 (yerli)	naturel eloksalli pers-renkli boyalı	W7-W8
W45-851 (yerli) W45-852 (yerli)	naturel eloksalli pers-renkli boyalı	W9-W10

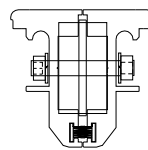

AKSESUARLAR ACCESSOIRES

PENCERE VE KAPI AÇILIM MEKANİZMALARI WINDOW AND DOOR OPENING MECHANISMS

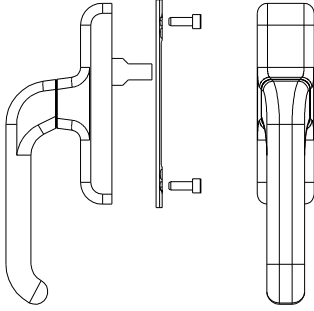

Tek maçalı normal açılım pencere kolu
Opening window handle

W-854 (yerli) (native)	W-854-a (yerli) (native)	naturel eloksalli (mat anodized)
W-855 (yerli) (native)	W-855-a (yerli) (native)	pres veya renkli (mill finishand and painted)

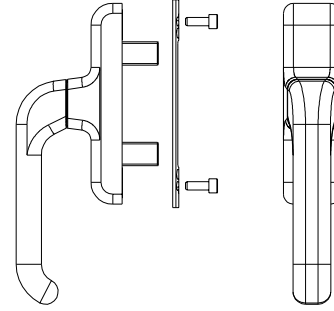

Çift maçalı normal açılım pencere kolu
Opening window handle

W-857 (ithal) (import)	W-857-a (yerli) (native)	naturel eloksalli (mat anodized)
W-858 (ithal) (import)	W-858-a (yerli) (native)	pres veya renkli (mill finishand and painted)



Anahtarlı aksenal kol
Key lockable window handle

W-860 (ithal) (import)	W-860-a (yerli) (native)	naturel eloksalli (mat anodized)
W-861 (ithal) (import)	W-861-a (yerli) (native)	pres veya renkli (mill finishand and painted)



Sökülebilir kol gövde
Opening window removing handle

W-863 (ithal) (import)	W-863-a (yerli) (native)	naturel eloksalli (mat anodized)
W-864 (ithal) (import)	W-864-a (yerli) (native)	pres veya renkli (mill finishand and painted)

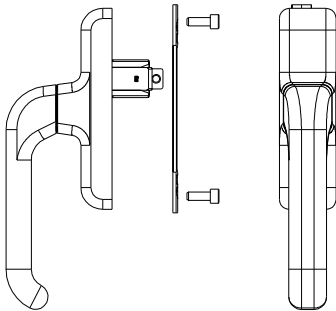

Çift açılım pencere kolu
Tilt and turn opening window handle

W-872 (ithal) (import)	W-872-a (yerli) (native)	naturel eloksalli (mat anodized)
W-873 (ithal) (import)	W-873-a (yerli) (native)	pres veya renkli (mill finishand and painted)

Gizli kanat kanal adaptör kapak (takım)
PVC adapter cover

W6-512 profili ile kullanılır
it can use with W6-512

W-874 W3-W4-W6-W8

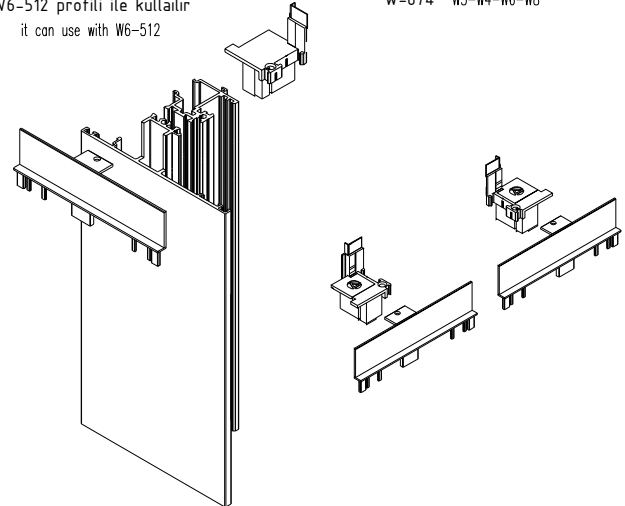

AKSESUARLAR ACCESSOIRES

PENCERE VE KAPI AÇILIM MEKANİZMALARI WINDOW AND DOOR OPENING MECHANISMS

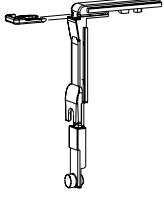

Köşe hareket aktarıcı
Corner transmission for window

W-875 (ithal) W-875-a (yerli)
(import) (native)



Pim karşılığı
Adjustable single striker

W-876 (ithal) W-876-a (yerli)
(import) (native)

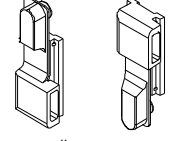

Tij bağlantı pabucu
Connection blocks

W-877 (ithal) W-877-a (yerli)
(import) (native)



Pim
Pin

W-878 (ithal) W-878-a (yerli)
(import) (native)

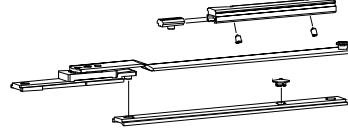

Çift açılım ilave makas
Tilt and turn annex arm

W-880 (ithal) W-880-a (yerli)
(import) (native)



Kol karşılığı
Cremone drive

W-882 (ithal)
(import)
W-882-a (yerli)
(native)



Sürgü ucu
Bolt tip

W-883 (ithal)
(import)
W-883-a (yerli)
(native)

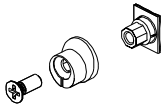

Ayarlanabilir pim
Adjustable fastening pawl

W-879 (ithal) W-879-a (yerli)
(import) (native)

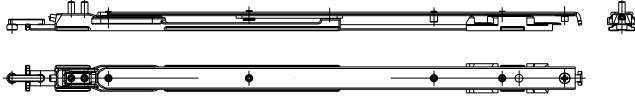

Çift açılım büyük makas (130kg)
Tilt and turn long arm (130kg)

W-881-80 (ithal) W-881-80-a (yerli) W-881-130 (ithal) W-881-130-a (yerli)
(import) (native) (import) (native)

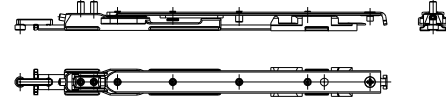

Çift açılım küçük makas (80kg)
Tilt and turn short arm (80kg)

W-884-80 (ithal) W-884-80-a (yerli) W-884-130 (ithal) W-884-130-a (yerli)
(import) (native) (import) (native)

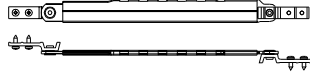

Kademeli teleskopik makas (inox)
Telescopic laser unit

W-885 (ithal) W-885-a (yerli)
(import) (native)



Kanat sarkma takozu
Wing rise stopper

W-887 (ithal)
(import)
W-887-a (yerli)
(native)



Çiftli sürgü karşılığı
Double keeper

W-888 (ithal)
(import)
W-888-a (yerli)
(native)



Kanat düşüş karşılığı
Wing drop keeper

W-889 (ithal)
(import)
W-889-a (yerli)
(native)

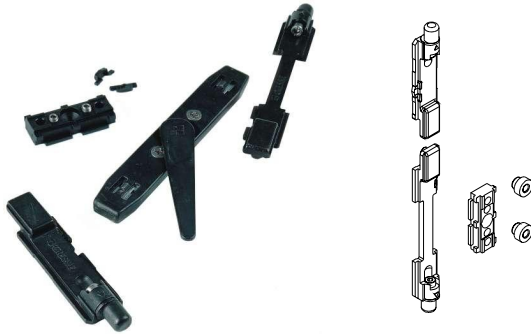

İkinci kanat sürge seti
Two-way lever push bolt

W-893 (ithal)
(import)
W-893-a (yerli)
(native)

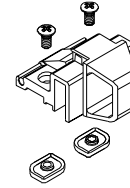

Vasistas cit cıt
Cico finger catch

W-894 (ithal) W-894-a (yerli) naturel eloksalı
(import) (native) (mat anodized)
W-895 (ithal) W-895-a (yerli) pres veya renkli
(import) (native) (mill finish and painted)

AKSESUARLAR ACCESSOIRES

PENCERE VE KAPI AÇILIM MEKANİZMALARI WINDOW AND DOOR OPENING MECHANISMS

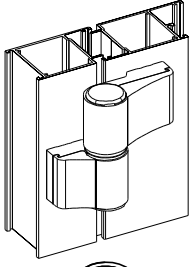

İki yapraklı kapı menteşesi
Two-leaf hinges for door

- | | | |
|---------------------------|-----------------------------|---|
| D-800 (ithal)
(import) | D-800-a (yerli)
(native) | naturel eloksalli
(mat anodized) |
| D-801 (ithal)
(import) | D-801-a (yerli)
(native) | pres veya renkli
(mill finish and painted) |

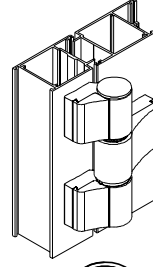

Üç yapraklı kapı menteşesi
Three-leaf hinges for door

- | | | |
|---------------------------|-----------------------------|---|
| D-803 (ithal)
(import) | D-803-a (yerli)
(native) | naturel eloksalli
(mat anodized) |
| D-804 (ithal)
(import) | D-804-a (yerli)
(native) | pres veya renkli
(mill finish and painted) |

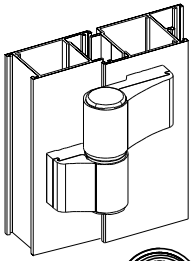
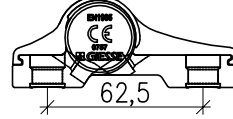

İki yapraklı kapı menteşesi
Two-leaf hinges for door

- | | | |
|---------------------------|-----------------------------|---|
| D-806 (ithal)
(import) | D-806-a (yerli)
(native) | naturel eloksalli
(mat anodized) |
| D-807 (ithal)
(import) | D-807-a (yerli)
(native) | pres veya renkli
(mill finish and painted) |

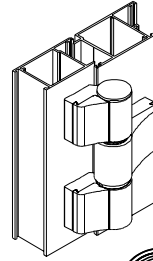
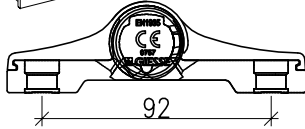

Üç yapraklı kapı menteşesi
Three-leaf hinges for door

- | | | |
|---------------------------|-----------------------------|---|
| D-809 (ithal)
(import) | D-809-a (yerli)
(native) | naturel eloksalli
(mat anodized) |
| D-810 (ithal)
(import) | D-810-a (yerli)
(native) | pres veya renkli
(mill finish and painted) |

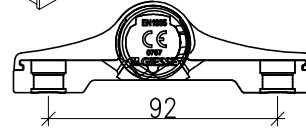

Menteşe kademe yükseltici
Step for hinges

- | | | |
|---------------------------|-----------------------------|---|
| D-888 (ithal)
(import) | D-888-a (yerli)
(native) | naturel eloksalli
(mat anodized) |
| D-889 (ithal)
(import) | D-889-a (yerli)
(native) | pres veya renkli
(mill finish and painted) |

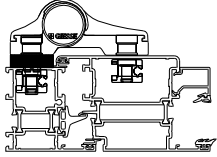

Menteşe kademe yükseltici
Step for hinges

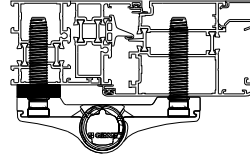

- | | | |
|---------------------------|-----------------------------|---|
| D-890 (ithal)
(import) | D-890-a (yerli)
(native) | naturel eloksalli
(mat anodized) |
| D-891 (ithal)
(import) | D-891-a (yerli)
(native) | pres veya renkli
(mill finish and painted) |

İki yapraklı kapı menteşesi için bağlantı takımı
Two-leaf hinges door for counterplates

- | | | |
|---------------------------|-----------------------------|-------------------------------------|
| D-892 (ithal)
(import) | D-892-a (yerli)
(native) | naturel eloksalli
(mat anodized) |
|---------------------------|-----------------------------|-------------------------------------|

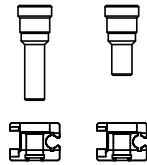
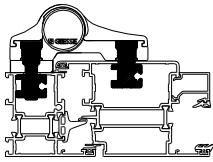

İki yapraklı kapı menteşesi için bağlantı takımı
Two-leaf hinges door for counterplates

- | | | |
|---------------------------|-----------------------------|-------------------------------------|
| D-893 (ithal)
(import) | D-893-a (yerli)
(native) | naturel eloksalli
(mat anodized) |
|---------------------------|-----------------------------|-------------------------------------|

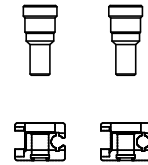
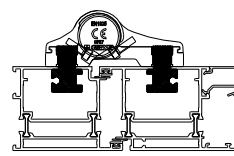

Üç yapraklı kapı menteşesi için bağlantı takımı
Three-leaf hinges door for counterplates

- | | | |
|---------------------------|-----------------------------|-------------------------------------|
| D-894 (ithal)
(import) | D-894-a (yerli)
(native) | naturel eloksalli
(mat anodized) |
|---------------------------|-----------------------------|-------------------------------------|

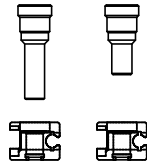
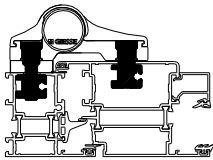

Üç yapraklı kapı menteşesi için bağlantı takımı
Three-leaf hinges door for counterplates

- | | | |
|---------------------------|-----------------------------|-------------------------------------|
| D-895 (ithal)
(import) | D-895-a (yerli)
(native) | naturel eloksalli
(mat anodized) |
|---------------------------|-----------------------------|-------------------------------------|

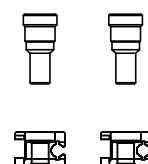
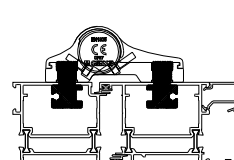

AKSESUARLAR ACCESSOIRES

PENCERE VE KAPI AÇILIM MEKANİZMALARI WINDOW AND DOOR OPENING MECHANISMS

İki ve üç yapraklı kapı menteşesi için bağlantı
Two and three-leaf hinges door for counterplates

D-896 (ithal) D-896-a (yerli) naturel eloksalli
(import) (native) (mat anodized)

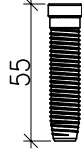
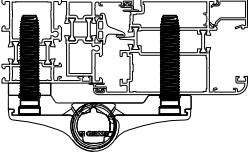

İki ve üç yapraklı kapı menteşesi için bağlantı
Two and three-leaf hinges door for counterplates

D-897 (ithal) D-897-a (yerli) naturel eloksalli
(import) (native) (mat anodized)

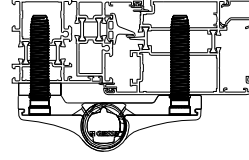

İki yapraklı kapı menteşesi (XL)
Two-leaf hinges for door (XL)

D-812 (ithal) D-812-a (yerli) naturel eloksalli
(import) (native) (mat anodized)
D-813 (ithal) D-813-a (yerli) pres veya renkli
(import) (native) (mill finish and painted)

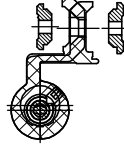

max.100 kg

Üç yapraklı kapı menteşesi (XXL)
Three-leaf hinges for door (XXL)

D-815 (ithal) D-815-a (yerli) naturel eloksalli
(import) (native) (mat anodized)
D-816 (ithal) D-816-a (yerli) pres veya renkli
(import) (native) (mill finish and painted)

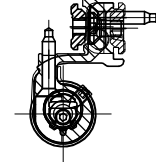

max.160 kg

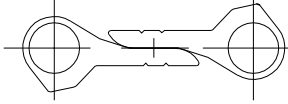

Çarpma kapı menteşesi
Swinging door hinges

D-818 (ithal) D-818-a (yerli)
(import) (native)
D-819 (ithal) D-819-a (yerli)
(import) (native)

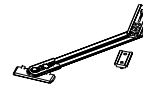

Limitleme makası (küçük)
Window stay (small)

W-886K (ithal) W-886K-a (yerli)
(import) (native)



Limitleme makası (büyük)
Window stay (big)

W-886 (ithal) W-886-a (yerli)
(import) (native)

AKSESUARLAR ACCESSOIRES

PENCERE VE KAPI AÇILIM MEKANİZMALARI WINDOW AND DOOR OPENING MECHANISMS

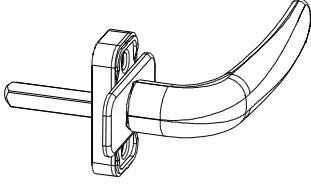

Prima kapı kolu
Prima handle

- D-821 (ithal) D-821-a (yerli) naturel eloksalli
(import) (native) (mat anodized)
- D-822 (ithal) D-822-a (yerli) pres veya renkli
(import) (native) (mill finishand and painted)

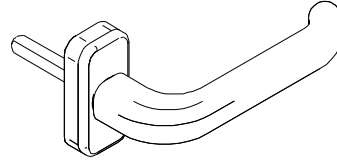

Prima kapı kolu (sağ-sol)
Prima handle (LH/RH)

- D-824 (ithal) D-824-a (yerli) naturel eloksalli
(import) (native) (mat anodized)
- D-825 (ithal) D-825-a (yerli) pres veya renkli
(import) (native) (mill finishand and painted)



Prima ikili kapı kolu
Prima handle couple

- D-827 (ithal) D-827-a (yerli) naturel eloksalli
(import) (native) (mat anodized)
- D-828 (ithal) D-828-a (yerli) pres veya renkli
(import) (native) (mill finishand and painted)



Supermaster ikili kapı kolu
Supermaster handle-couple

- D-830 (ithal) D-830-a (yerli) naturel eloksalli
(import) (native) (mat anodized)
- D-831 (ithal) D-831-a (yerli) pres veya renkli
(import) (native) (mill finishand and painted)

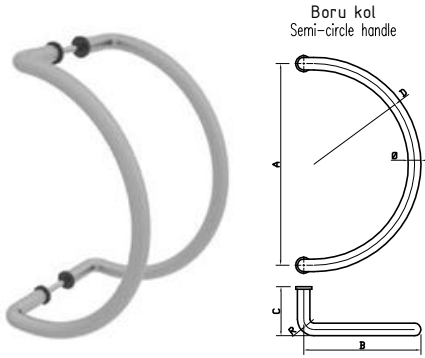

Boru kol
Semi-circle handle

- D-833-X
naturel eloksalli
(mat anodized)
- D-834-X
pres veya renkli
(mill finishand and painted)

X	Ø	R	A	B	C	D
1	20	25	110	110	60	55
2	20	25	150	130	60	75
3	20	25	200	140	60	100
4	25	40	200	150	80	100
5	25	40	300	210	80	150
6	25	40	400	250	80	200
7	30	55	300	250	80	150
8	30	55	350	250	80	175
9	32	55	300	250	80	150
10	32	55	350	175	80	175



Boru kol
Semi-circle curved handle

- D-836-X
naturel eloksalli
(mat anodized)
- D-837-X
pres veya renkli
(mill finishand and painted)

X	Ø	R	A	B	C
1	20	25	110	90	50
2	20	25	150	90	60
3	20	25	200	90	60
4	25	40	200	100	80
5	25	40	250	100	80
6	25	40	300	100	80
7	25	40	350	100	80
8	25	40	400	100	80
9	30	40	300	100	80
10	30	50	350	130	80
11	30	50	600	130	80
12	32	50	300	150	80
13	32	50	350	150	80



Boru kol
Spring handle

- D-839-X
naturel eloksalli
(mat anodized)
- D-840-X
pres veya renkli
(mill finishand and painted)

X	Ø	R	A	B	C
1	30	750	600	1500	75
2	30	750	750	1600	75

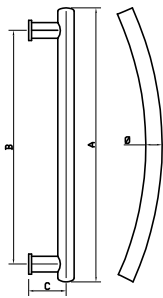

Düz-kıvrık aynalı kol
Flat-curve mirrored handles

- D-842-X
naturel eloksalli
(mat anodized)
- D-843-X
pres veya renkli
(mill finishand and painted)

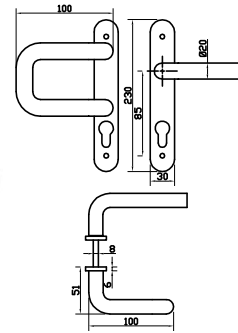

Lama bant kol
Lama stripe handle

- D-845-X
naturel eloksalli
(mat anodized)

- D-846-X
pres veya renkli
(mill finishand and painted)

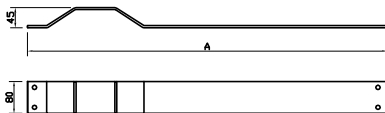

X	A
1	900
2	1000

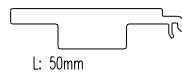

L: 50mm

Cam altı takozu (yerli)
Glass support piece (native)

- D-869 W1-W2-W3-W4-D1-D2
D65-869 W5-W6-S3
D75-869 W7-W8
D45-869 W9-W10

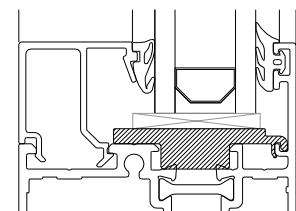

AKSESUARLAR ACCESSOIRES

PENCERE VE KAPI AÇILIM MEKANİZMALARI WINDOW AND DOOR OPENING MECHANISMS

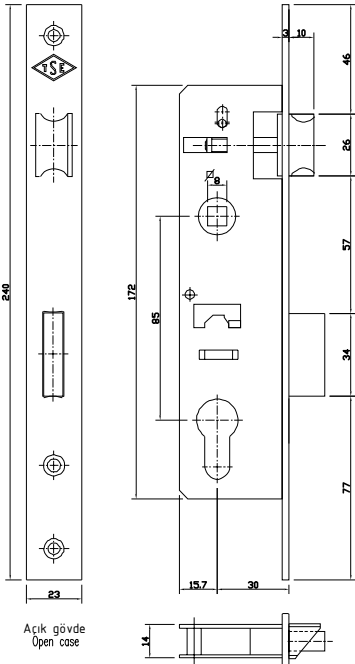

Açık gövde
Open case



153U-30
Dar kilit(dilli)
Narrow lock (bolt)
D-874 (yerli) metalik
(native) metallic

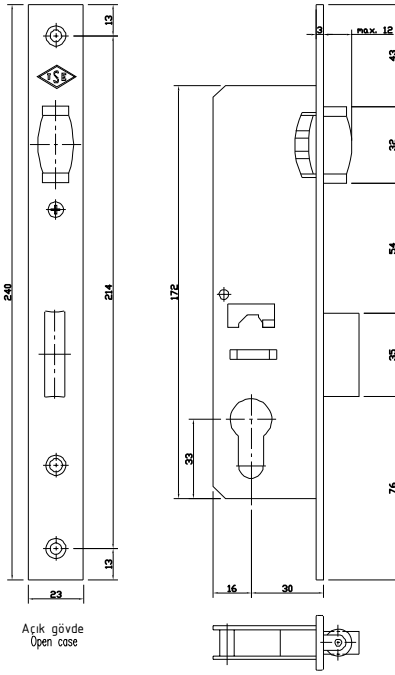

Açık gövde
Open case



155U-30
Dar kilit (makaralı)
Narrow lock (roller)
D-876 (yerli) metalik
(native) metallic

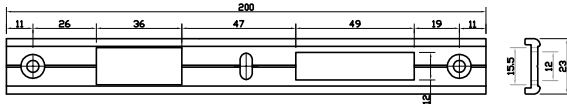

D-851 (yerli) naturel
D-852 (yerli) pres-renkli boyalı

kilit karşılığı
lock plate

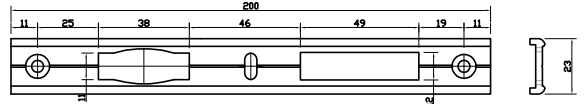

D-854 (yerli) naturel
D-855 (yerli) pres-renkli boyalı

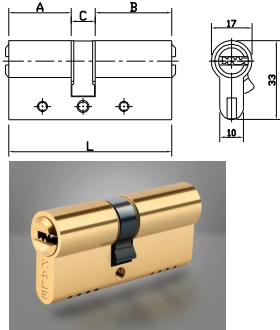

A	C	B	L	Barel Cylinders
26	10	26	62	D-878-1 (yerli) metalik
26	10	32	68	D-878-2 (yerli) metalik
30	10	40	80	D-878-3 (yerli) metalik
30	10	45	85	D-878-4 (yerli) metalik
30	10	50	90	D-878-5 (yerli) metalik
30	10	60	100	D-878-6 (yerli) metalik
25	10	65	100	D-878-7 (yerli) metalik
25	10	70	105	D-878-8 (yerli) metalik

Barel rozeti
Cylinder cover



D-848-1 naturel eloksalli (mat anodized)
D-848-2 pres veya renkli (mill finishand and painted)



D-849-1 naturel eloksalli (mat anodized)
D-849-2 pres veya renkli (mill finishand and painted)



D-850-1 naturel eloksalli (mat anodized)
D-850-2 pres veya renkli (mill finishand and painted)

